

DATA SHEET

SKY65053-377LF: 0.45-6.0 GHz Low Noise Transistor

Applications

- Wireless infrastructure: WLAN, WiMAX, broadband, cellular base stations
- Test instrumentation
- LNA for GPS receivers
- Satellite receivers

Features

- Externally matched for wideband operation
- Noise Figure = 0.6 dB @ 2.4 GHz of device only
- Noise Figure = 0.8 dB @ 2.4 GHz including matching network loss
- Gain = 16.5 dB @ 2.4 GHz, 5 V, 55 mA
- OIP3 = +33.5 dBm @ 2.4 GHz, 5 V, 55 mA
- OP1dB = +15.5 dBm @ 2.4 GHz, 5 V, 55 mA
- Adjustable supply current, 15 to 100 mA
- Unconditionally stable to 18 GHz with reference design circuit
- Small, QFN (4-pin, 2 x 2 mm) Pb-free package (MSL3, 260 °C per JEDEC J-STD-020)

NEW



Skyworks Green™ products are RoHS (Restriction of Hazardous Substances)-compliant, conform to the EIA/EICTA/JEITA Joint Industry Guide (JIG) Level A guidelines, are halogen free according to IEC-61249-2-21, and contain <1,000 ppm antimony trioxide in polymeric materials.

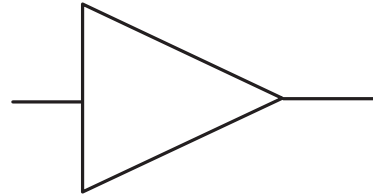

Figure 1. SKY65053-377LF Block Diagram

Description

The SKY65053-377LF is a high performance, n-channel low-noise transistor. The device is fabricated from Skyworks advanced depletion mode pHEMT process and is provided in a 2 x 2 mm, 4-pin Quad Flat No-Lead (QFN) package.

The transistor's low Noise Figure (NF), high gain, and excellent 3rd Order Intercept Point (IP3) allow the device to be used in various receiver and transmitter applications.

A functional block diagram is shown in Figure 1. The pin configuration and package are shown in Figure 2. Signal pin assignments and functional pin descriptions are provided in Table 1.

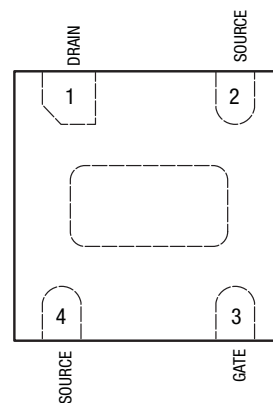

Figure 2. SKY65053-377LF Pinout – 4-Pin QFN (Top View)

Table 1. SKY65053-377LF Signal Descriptions

Pin #	Name	Description	Pin #	Name	Description
1	DRAIN	RF output. Supply voltage required through external RF choke.	3	GATE	RF input
2	SOURCE	Source lead. Provides DC self-biasing point and AC ground.	4	SOURCE	Source lead. Provides DC self-biasing point and AC ground.

Functional Description

The SKY65053-377LF is a depletion mode pHEMT designed for low noise, high frequency applications that demand high linearity. The SKY65053-377LF has a typical NF of 0.8 dB tested at the 2.4 GHz wireless LAN frequency band. A gain of 16.5 dB typical is achieved using the same circuit. The SKY65053-377LF can be used for any application from 450 MHz up to 6 GHz.

Biasing

To properly bias a depletion mode pHEMT, both the gate and drain of the device must be properly biased. At $V_{GS} = 0\text{ V}$ and $V_{DS} \geq 2\text{ V}$, the device is in its saturated state and draws the maximum amount of current, I_{DSS} . Typically, the device achieves the best balance of noise and linearity performance at $V_{DS} = 5\text{ V}$ and $I_{DS} = 55\text{ mA}$. To control I_{DS} , V_{GS} must be biased with a negative voltage supply.

To eliminate the need for a negative DC supply, self-biasing should be used when a resistor is placed between one of the source leads and ground. A bypass capacitor should be placed in parallel to this resistor to provide an RF ground and to ensure performance at the operating frequency remains unchanged.

When current flows from drain to source and through the resistor, the source voltage becomes biased above DC ground. The gate pin of the device should be left unbiased at 0 V, which creates the desired negative V_{GS} value. This greatly simplifies the design by eliminating the need for a second DC supply.

RF Matching Networks

The circuit schematic (see Figure 12) shows the recommended RF matching network used for the 2.4 GHz wireless LAN frequency band. Components C1, C2, L1, and L2 provide the necessary impedance match for NF and input return loss. Circuit board and

input matching structure losses on the input of the amplifier add directly to the overall NF of the amplifier. It is critical to minimize RF trace lengths and to use high-Q components to achieve optimal NF performance.

Components R1 and C10 provide self-bias for the device and RF grounding for one of the two source leads. Component C6 is placed on the opposing source lead and is used to tune the transistor’s internal source inductance.

The effect of source inductance varies with frequency. Too little source inductance increases gain and high frequency stability, but at the cost of decreased in-band stability. Too much source inductance decreases high frequency stability and gain, but increases in-band stability. It is very important to find the optimum tuning of source inductance that balances all of these variables.

The output matching topology is typical for an RF amplifier. Component L4 is the RF choke that prevents RF signals from reaching the DC supply. Component C11 is the output DC blocking capacitor. Components C12 and L6 provide the best impedance match for best linearity performance.

Electrical and Mechanical Specifications

The absolute maximum ratings of the SKY65053-377LF are provided in Table 2. The recommended operating conditions are specified in Table 3 and electrical specifications are provided in Table 4.

Performance characteristics for the SKY65053-377LF are illustrated in Figures 3 through 10.

Table 2. SKY65053-377LF Absolute Maximum Ratings

Parameter	Symbol	Minimum	Typical	Maximum	Units
Supply voltage	V _{DD}		6		V
Input power	P _{IN}		+15		dBm
Gate to source voltage	V _{GS}		-5.0		V
Gate to drain voltage	V _{GD}		-5.0		V
Drain to source current	I _{DS}		110		mA
Gate to drain current	I _{GD}		100		μA
Power dissipation	P _{DIS}		240		mW
Junction temperature	T _J		150		°C
Storage temperature	T _{STG}	-65		+125	°C
Operating temperature	T _{OP}	-40		+85	°C
Thermal resistance	Θ _{JC}		220		°C/W

Note: Exposure to maximum rating conditions for extended periods may reduce device reliability. There is no damage to device with only one parameter set at the limit and all other parameters set at or below their nominal value.

CAUTION: Although this device is designed to be as robust as possible, Electrostatic Discharge (ESD) can damage this device. This device must be protected at all times from ESD. Static charges may easily produce potentials of several kilovolts on the human body or equipment, which can discharge without detection. Industry-standard ESD precautions should be used at all times.

Table 3. SKY65053-377LF Recommended Operating Conditions

Parameter	Symbol	Minimum	Typical	Maximum	Units
Operating frequency	f	0.45		6.0	GHz
Supply voltage	V _{DD}	2.00	5.00	5.25	V
Supply current	I _{DD}	15	55	100	mA

Table 4. SKY65053-377LF Electrical Specifications (Note 1) (1 of 2)

(T_{OP} = +25 °C, Characteristic Impedance [Z₀] = 50 Ω, V_{DD} = 5 V, I_{DD} = 55 mA, Parameters Include Recommended Matching Networks, Unless Otherwise Noted)

Parameter	Symbol	Test Condition	Min	Typical	Max	Units
Saturated drain current	I _{DSS}	V _{DS} = 6 V, V _{GS} = 0 V	80	100	120	mA
Pinchoff voltage	V _P	V _{DS} = 6 V, I _{DS} = 2.5% of I _{DSS}	-0.95	-0.80	-0.65	V
Transconductance	g _M	V _{DS} = 6 V, g _M = ΔI _{DS} /ΔV _{GS} , measured at I _{DS} = 20% of I _{DSS}	80	120	160	mS
Gate leakage current	I _{GSS}	V _{GD} = V _{GS} = -3 V		1	200	μA
Noise Figure	NF1 (Note 2) NF2 (Note 3)			0.6 0.8		dB dB
Gain	S ₂₁			16.5		dB
Input return loss	S ₁₁			-12		dB
Output return loss	S ₂₂			-7		dB

Table 4. SKY65053-377LF Electrical Specifications (Note 1) (2 of 2)

($T_{OP} = +25\text{ }^{\circ}\text{C}$, Characteristic Impedance [Z_0] = 50 Ω , $V_{DD} = 5\text{ V}$, $I_{DD} = 55\text{ mA}$, Parameters Include Recommended Matching Networks, Unless Otherwise Noted)

Parameter	Symbol	Test Condition	Min	Typical	Max	Units
Reverse isolation	S12			-25		dB
3 rd Order Output Intercept Point	OIP3	$P_{OUT} = +5\text{ dBm/ tone}$, 1 MHz spacing		+33.5		dBm
3 rd Order Input Intercept Point	IIP3	$P_{OUT} = +5\text{ dBm/ tone}$, 1 MHz spacing		+17		dBm
1 dB Output Compression Point	OP1dB			+15.5		dBm
1 dB Input Compression Point	IP1dB			0		dBm
Stability		Unconditionally stable up to 18 GHz		>1		K

Note 1: Performance is guaranteed only under the conditions listed in this Table and is not guaranteed over the full operating or storage temperature ranges. Exceeding any of the conditions listed here may result in permanent damage to the device. Operation at elevated temperatures may reduce reliability of the device.

Note 2: NF of device only. Input RF connector, board, and input matching network loss de-embedded from measurement.

Note 3: NF of device and matching network. Input RF connector and board loss de-embedded from measurement.

Typical Performance Characteristics

($T_{OP} = +25\text{ }^{\circ}\text{C}$, Characteristic Impedance [Z_0] = 50 Ω , $V_{DD} = 5\text{ V}$, $I_{DD} = 55\text{ mA}$, Includes Recommended 2.4 GHz Matching Network, Unless Otherwise Noted)

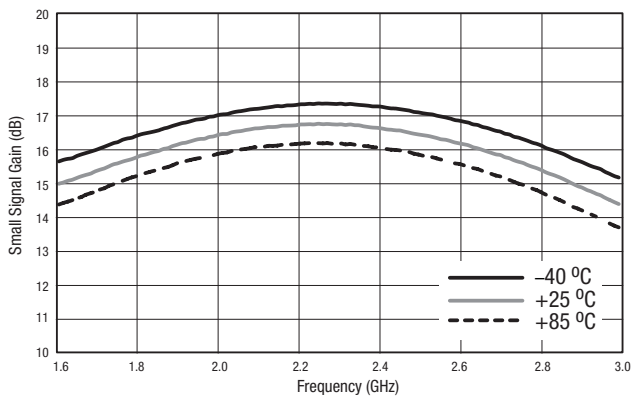

Figure 3. Small Signal Gain vs Frequency Over Temperature ($P_{IN} = -20\text{ dBm}$)

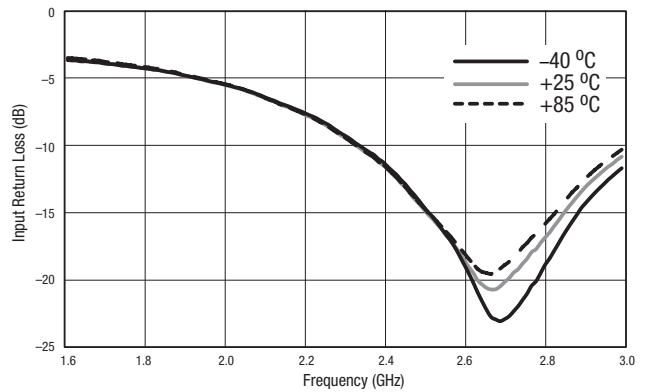

Figure 4. Input Return Loss vs Frequency Over Temperature ($P_{IN} = -20\text{ dBm}$)

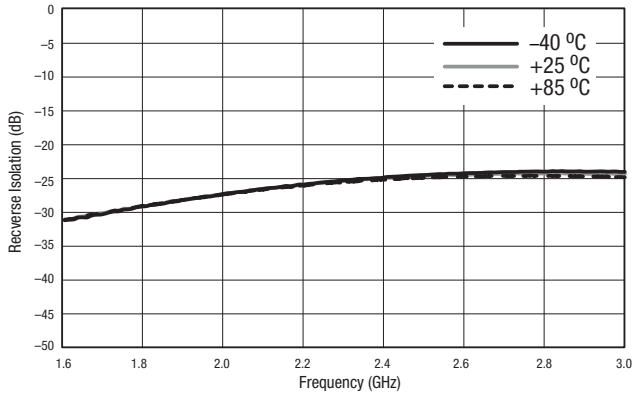

Figure 5. Reverse Isolation vs Frequency Over Temperature
($P_{IN} = -20$ dBm)

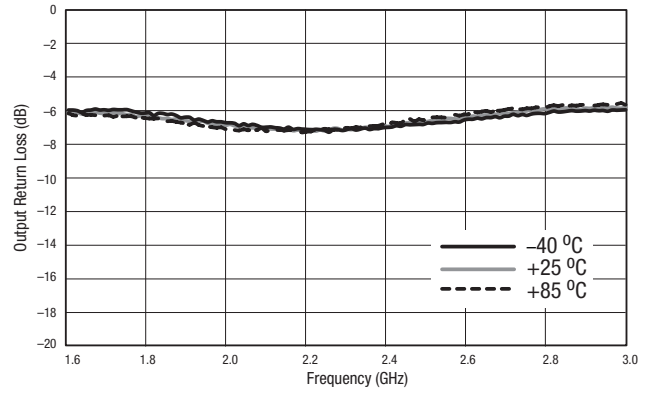

Figure 6. Output Return Loss vs Frequency Over Temperature
($P_{IN} = -20$ dBm)

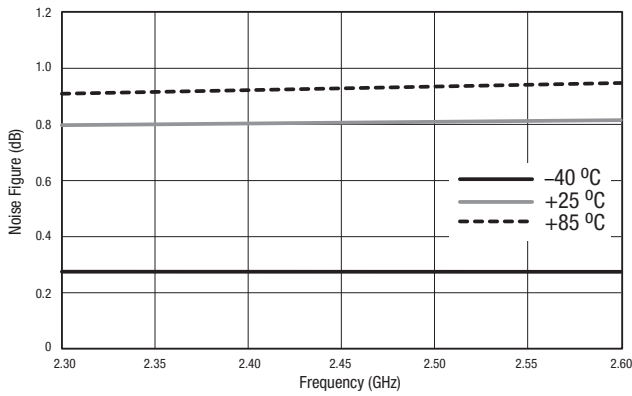

Figure 7. Noise Figure vs Frequency Over Temperature

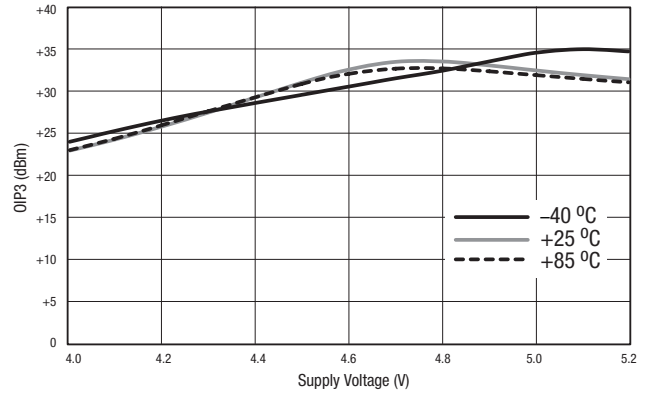

Figure 8. OIP3 vs Supply Voltage
($f = 2.4$ GHz, Tone Spacing = 10 MHz, $P_{OUT} = +5$ dBm/Tone)

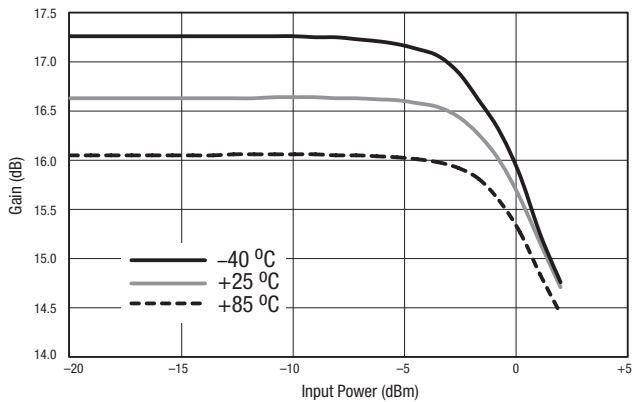

Figure 9. Gain vs Input Power Over Temperature
($f = 2.4$ GHz)

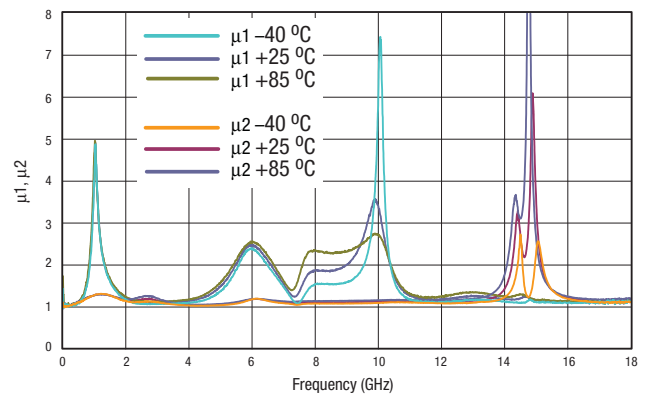

Figure 10. Stability vs Frequency Over Temperature
($P_{IN} = -20$ dBm)

Evaluation Board Description

The SKY65053-377LF Evaluation Board is used to test the performance of the SKY65053-377LF low noise transistor. An assembly drawing for the Evaluation Board is shown in Figure 11. The Evaluation Board schematic diagram is shown in Figure 12. Table 5 provides the Bill of Materials (BOM) list for Evaluation Board components.

Circuit Design Considerations

Input and output traces have been minimized to reduce losses. All surface mount components are 0402-sized to reduce component parasitics. Use of 0603 or larger components is not recommended. Component spacing has also been minimized. The board is provisioned with two RF connectors and a DC launch. RF connector and board loss up to component C1 is approximately 0.1 dB at 2.4 GHz.

It is very important to place multiple ground vias as close to shunt components as possible. This ensures proper grounding and circuit performance.

Board material is 10 mil VT47 FR4 with 1 oz. copper cladding. The RF traces are 50 Ω .

Caution: Do not ground the exposed pad.

Evaluation Board Test Procedure

- Step 1: Connect RF test equipment to amplifier input/output SMA connectors.
- Step 2: Connect DC ground.
- Step 3: Connect VDD to a +5 V supply with a current limit of 100 mA. Verify that the board draws approximately 55 mA.
- Step 4: Apply RF signal or noise source.

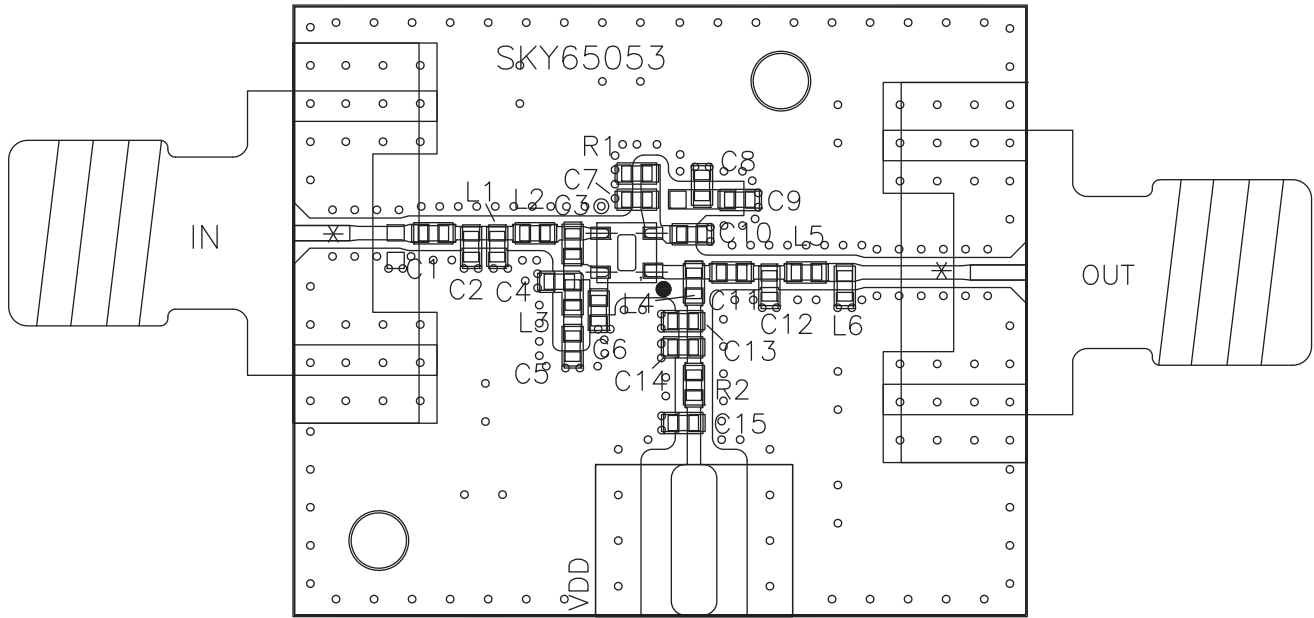

Caution: Do not ground the exposed pad.

S1512

Figure 11. SKY65053-377LF Evaluation Board Assembly Diagram

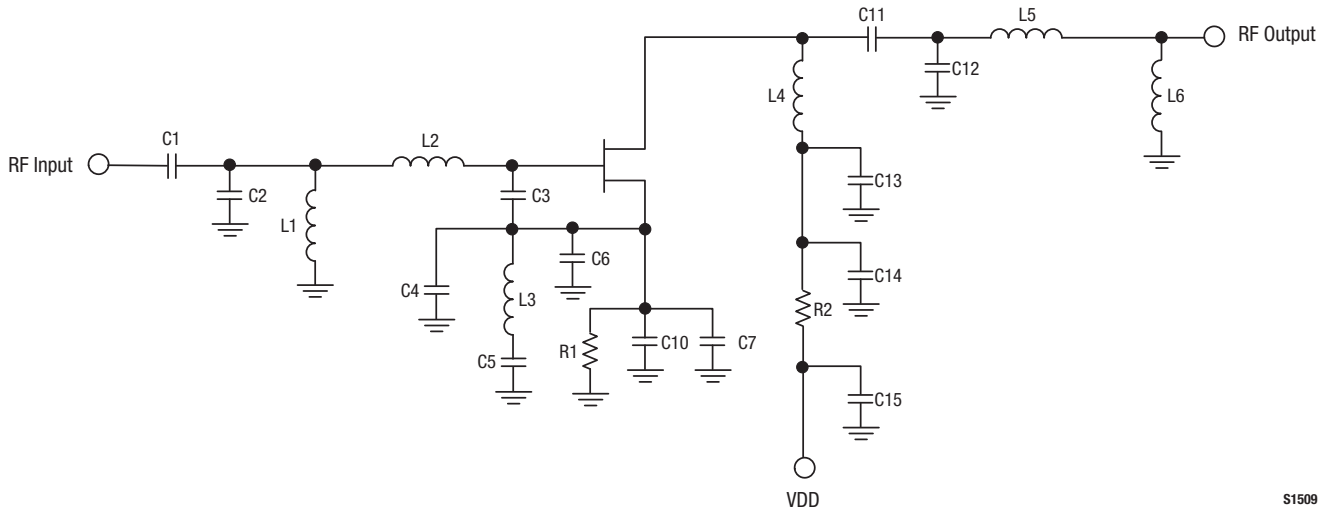

S1509

Figure 12. SKY65053-377LF Evaluation Board Schematic

Table 5. SKY65053-377LF Evaluation Board Bill of Materials

Component	Value	Size	Manufacturer/Part Series
C1	33 pF	0402	Murata GRM015
C2	1.2 pF	0402	Murata GJM015
C3	0.3 pF	0402	Murata GJM015
C4, C5, C7, C8, C9, C14	DNP		
C6	10000 pF	0402	Murata GRM015
C10	10000 pF	0402	Murata GRM015
C11	3.6 pF	0402	Murata GJM015
C12	0.3 pF	0402	Murata GJM015
C13	3.9 pF	0402	Murata GRM015
C15	1000 pF	0402	Murata GRM015
L1	12 nH	0402	Coilcraft HP
L2	2 nH	0402	Coilcraft HP
L3	DNP		
L4	5.6 nH	0402	Coilcraft HP
L5	0 Ω	0402	Panasonic
L6	6.8 nH	0402	Taiyo Yuden HK
R1	4.7 Ω	0402	Panasonic
R2	39 Ω	0402	Panasonic

Package Dimensions

The PCB layout footprint for the SKY65053-377LF is shown in Figure 13. Typical case markings are shown in Figure 14. Package dimensions for the 4-pin QFN are shown in Figure 15, and tape and reel dimensions are provided in Figure 16.

Package and Handling Information

Since the device package is sensitive to moisture absorption, it is baked and vacuum packed before shipping. Instructions on the shipping container label regarding exposure to moisture after the container seal is broken must be followed. Otherwise, problems

related to moisture absorption may occur when the part is subjected to high temperature during solder assembly.

THE SKY65053-377LF is rated to Moisture Sensitivity Level 3 (MSL3) at 260 °C. It can be used for lead or lead-free soldering.

Care must be taken when attaching this product, whether it is done manually or in a production solder reflow environment. Production quantities of this product are shipped in a standard tape and reel format.

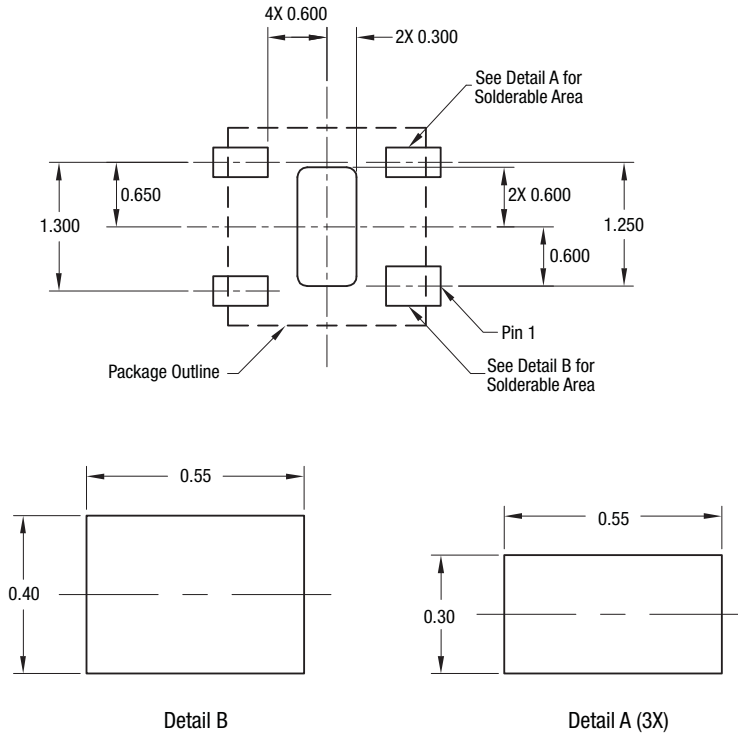

Caution: Do not ground the exposed pad.

S1416

Figure 13. SKY65053-377LF PCB Layout Footprint

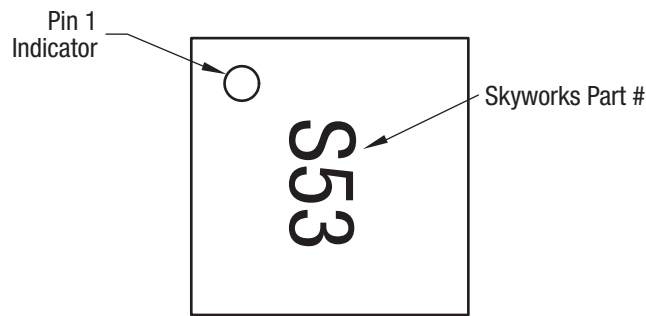
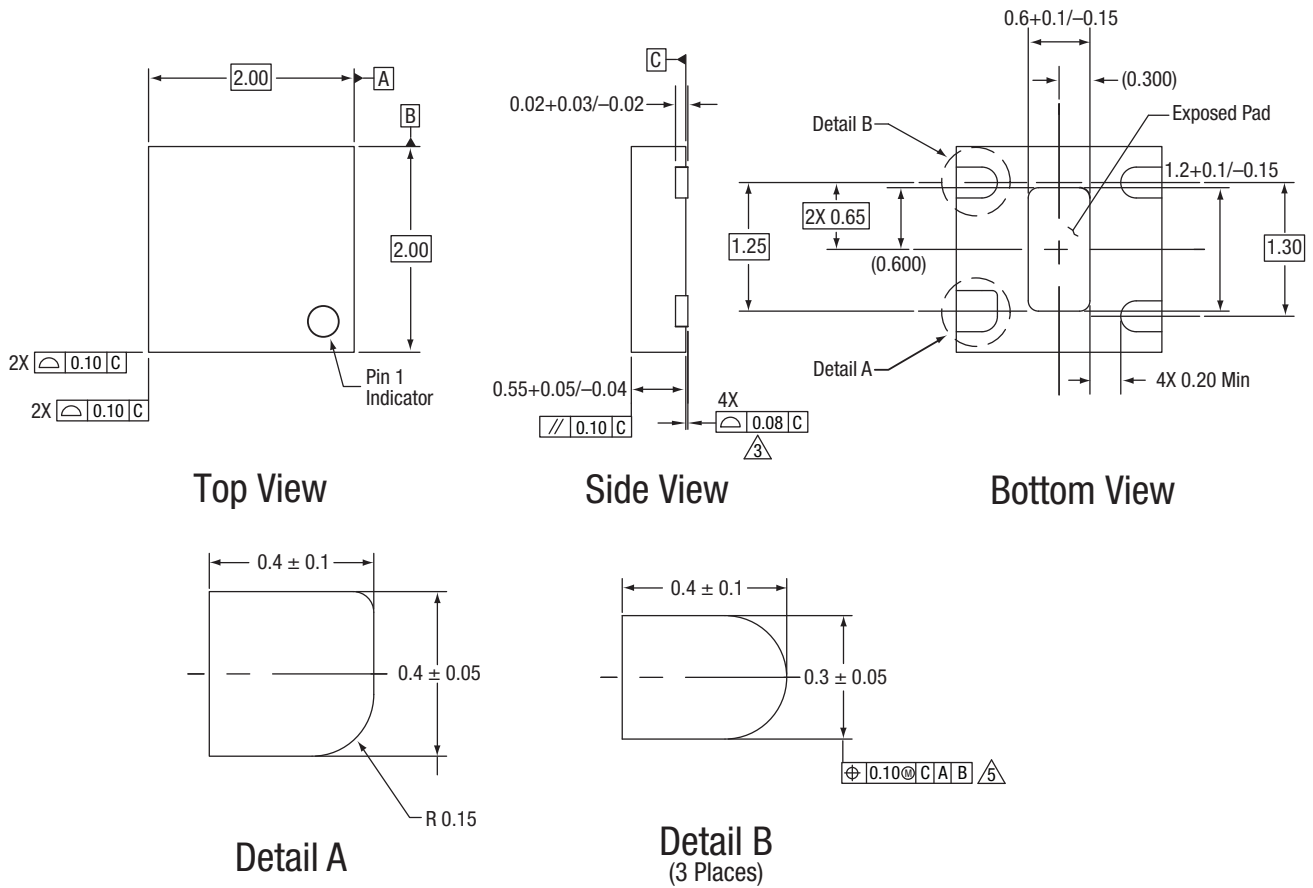

Figure 14. Typical Case Markings (Top View)



All measurements are in millimeters.
Dimensioning and tolerancing according to ASME Y14.5M-1994.

S1411

Figure 15. SKY65053-377LF 4-Pin QFN Package Dimensions

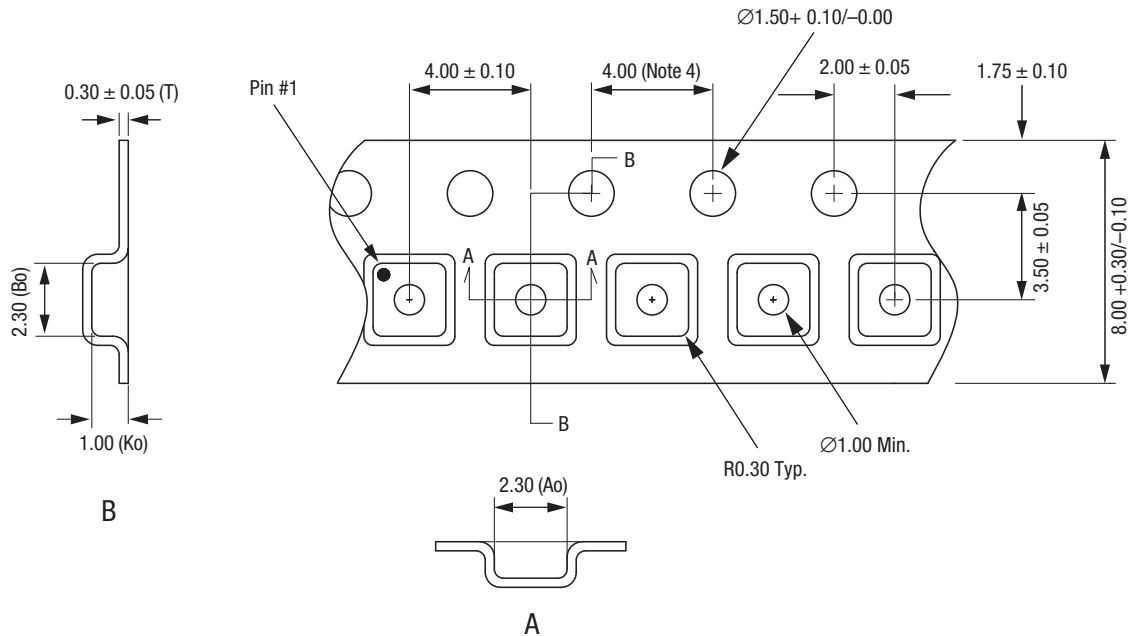

- Notes:
1. Carrier tape: black conductive polystyrene.
 2. Cover tape material: transparent conductive HSA.
 3. Cover tape size: 5.40 mm width.
 4. Ten sprocket hole pitch cumulative tolerance ± 0.20 mm.
 5. Ao and Bo measurement point to be 0.30 mm from bottom pocket.
 6. All measurements are in millimeters.

S1555

Figure 16. SKY65053-377LF Tape and Reel Dimensions

Ordering Information

Model Name	Manufacturing Part Number	Evaluation Board Part Number
SKY65053-377LF Low Noise Transistor	SKY65053-377LF	SKY65053-377LF-EVB

Copyright © 2009 Skyworks Solutions, Inc. All Rights Reserved.

Information in this document is provided in connection with Skyworks Solutions, Inc. ("Skyworks") products or services. These materials, including the information contained herein, are provided by Skyworks as a service to its customers and may be used for informational purposes only by the customer. Skyworks assumes no responsibility for errors or omissions in these materials or the information contained herein. Skyworks may change its documentation, products, services, specifications or product descriptions at any time, without notice. Skyworks makes no commitment to update the materials or information and shall have no responsibility whatsoever for conflicts, incompatibilities, or other difficulties arising from any future changes.

No license, whether express, implied, by estoppel or otherwise, is granted to any intellectual property rights by this document. Skyworks assumes no liability for any materials, products or information provided hereunder, including the sale, distribution, reproduction or use of Skyworks products, information or materials, except as may be provided in Skyworks Terms and Conditions of Sale.

THE MATERIALS, PRODUCTS AND INFORMATION ARE PROVIDED "AS IS" WITHOUT WARRANTY OF ANY KIND, WHETHER EXPRESS, IMPLIED, STATUTORY, OR OTHERWISE, INCLUDING FITNESS FOR A PARTICULAR PURPOSE OR USE, MERCHANTABILITY, PERFORMANCE, QUALITY OR NON-INFRINGEMENT OF ANY INTELLECTUAL PROPERTY RIGHT; ALL SUCH WARRANTIES ARE HEREBY EXPRESSLY DISCLAIMED. SKYWORKS DOES NOT WARRANT THE ACCURACY OR COMPLETENESS OF THE INFORMATION, TEXT, GRAPHICS OR OTHER ITEMS CONTAINED WITHIN THESE MATERIALS. SKYWORKS SHALL NOT BE LIABLE FOR ANY DAMAGES, INCLUDING BUT NOT LIMITED TO ANY SPECIAL, INDIRECT, INCIDENTAL, STATUTORY, OR CONSEQUENTIAL DAMAGES, INCLUDING WITHOUT LIMITATION, LOST REVENUES OR LOST PROFITS THAT MAY RESULT FROM THE USE OF THE MATERIALS OR INFORMATION, WHETHER OR NOT THE RECIPIENT OF MATERIALS HAS BEEN ADVISED OF THE POSSIBILITY OF SUCH DAMAGE.

Skyworks products are not intended for use in medical, lifesaving or life-sustaining applications, or other equipment in which the failure of the Skyworks products could lead to personal injury, death, physical or environmental damage. Skyworks customers using or selling Skyworks products for use in such applications do so at their own risk and agree to fully indemnify Skyworks for any damages resulting from such improper use or sale.

Customers are responsible for their products and applications using Skyworks products, which may deviate from published specifications as a result of design defects, errors, or operation of products outside of published parameters or design specifications. Customers should include design and operating safeguards to minimize these and other risks. Skyworks assumes no liability for applications assistance, customer product design, or damage to any equipment resulting from the use of Skyworks products outside of stated published specifications or parameters.

Skyworks, the Skyworks symbol, and "Breakthrough Simplicity" are trademarks or registered trademarks of Skyworks Solutions, Inc., in the United States and other countries. Third-party brands and names are for identification purposes only, and are the property of their respective owners. Additional information, including relevant terms and conditions, posted at www.skyworksinc.com, are incorporated by reference.