

Code No:	Total Pages	Page
	26	1

Product Standards

Part No.	AN26210A
Package Code No.	XLGA012-L-0303

Analogue LSI Business Unit
 Semiconductor Company
 Matsushita Electric Industrial Co., Ltd.

Established by	Applied by	Checked by	Prepared by
K.Komichi	M.Hiramatsu	M.Ishida	J.Ito

2007-02-27		
Established	Revised	

	Product Standards	AN26210A	
		Total Pages	Page
		26	2

Contents

■ Overview	3
■ Features	3
■ Applications	3
■ Package	3
■ Type	3
■ Application Circuit Example	4
■ Pin Descriptions	5
■ Current and Voltage Range for Pins	6
Absolute Maximum Ratings	7
■ Operating Supply Voltage Range	7
■ Electrical Characteristics	8
■ Electrical Characteristics (Referred design parameters)	11
■ Control Pins Mode Table	20
■ Truth Table	20
■ Test Circuit Diagram	21
■ Technical Data	24
• I/O block circuit diagram & pin function descriptions	24

2007-02-27		
Established	Revised	

	<h1>Product Standards</h1>	AN26210A	
		Total Pages	Page
		26	3

AN26210A

W-CDMA Dual Band LNA-IC

■ Overview

- AN26210A is LNA-IC for dual band(800MHz/2.1GHz) WCDMA.
- Realizing high performance by using 0.25 μm SiGe Bi-CMOS process($f_T = 50 \text{ GHz}$, $f_{\text{max}} = 60 \text{ GHz}$).
- Each Bands are selectable and Gain-mode is changeable, controlled by integrated CMOS logic circuit.
- Achieving miniaturization by using small size XLGA package.

■ Features

- Low voltage operation +2.85 V typ.
- Low current consumption 4.5 mA typ. (High-Gain mode)
0.1 μA typ. (Low-Gain mode)
- High gain 17.0 dB typ. $f_{\text{RX}} = 2140 \text{ MHz}$ (High-Gain mode)
17.0 dB typ. $f_{\text{RX}} = 880 \text{ MHz}$ (High-Gain mode)
- Low noise figure 1.55 dB typ. $f_{\text{RX}} = 2140 \text{ MHz}$ (High-Gain mode)
1.10 dB typ. $f_{\text{RX}} = 880 \text{ MHz}$ (High-Gain mode)
- Low distortion 2.5 dBm typ. $f_{\text{RX}} = 2140 \text{ MHz}$ (High-Gain mode)
(IIP3 +10 MHz offset) 2.0 dBm typ. $f_{\text{RX}} = 880 \text{ MHz}$ (High-Gain mode)
- Small package (XLGA)

■ Applications

- W-CDMA dual-band terminals

■ Package

- 12 pin Fine Pitch Land Grid Array Package (LGA Type)

■ Type

- Bi-CMOS IC

2007-02-27		
Established	Revised	

■ Application Circuit Example

Note) External components : See page 23

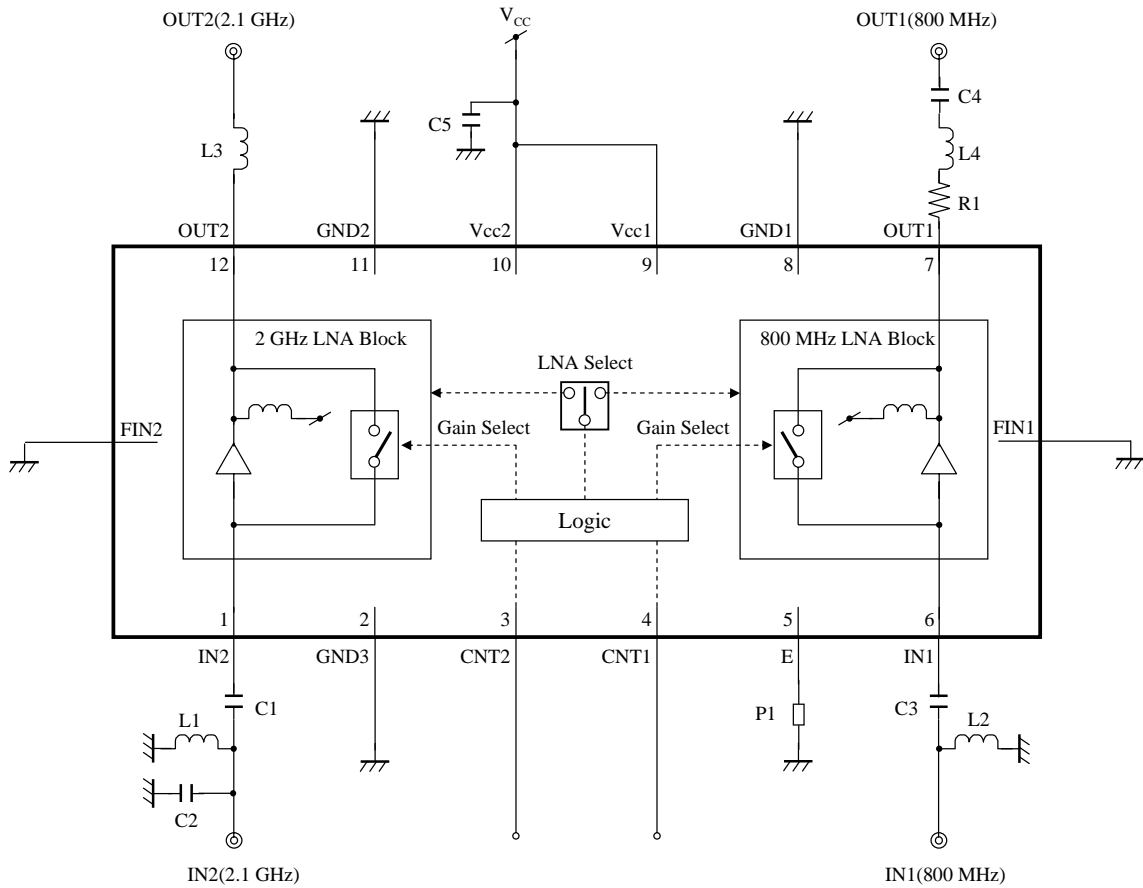

2007-02-27		
Established	Revised	

	Product Standards	AN26210A	
		Total Pages	Page
		26	5

■ Pin Descriptions

Pin No.	Pin name	Type	Description
1	IN2	Input	2.1 GHz RF Input
2	GND3	Ground	GND
3	CNT2	Input	High-Gain / Low-Gain SW
4	CNT1	Input	800 MHz / 2.1 GHz SW
5	E	Output	Emitter
6	IN1	Input	800 MHz RF Input
FIN1	FIN1	Ground	GND
7	OUT1	Output	800 MHz RF Output
8	GND1	Ground	GND
9	Vcc1	Power Supply	V _{CC}
10	Vcc2	Power Supply	V _{CC}
11	GND2	Ground	GND
12	OUT2	Output	2.1 GHz RF Output
FIN2	FIN2	Ground	GND

2007-02-27		
Established	Revised	

	<h1>Product Standards</h1>	<h2>AN26210A</h2>	
		Total Pages	Page
		26	6

■ Current and Voltage Range for Pins

Notes) • Do not apply voltage to N.C. pins.

- The values shows voltage to the GND unless otherwise specified. (+) is inlet current and (-) is outlet current in the circuit.
- Voltage applying exceeding below ratings leads to the malfunction and the damage of the device.
- Below ratings are specified regarding malfunction and stress, not for operation guaranty.

Pin No.	Pin name	Rating	Unit	Notes
1	IN2	- 0.3 to (V _{CC})	V	*1
2	GND3	0	V	*3
3	CNT2	- 0.3 to (V _{CC})	V	
4	CNT1	- 0.3 to (V _{CC})	V	
5	E	- 0.3 to (V _{CC} - 1 / 2)	V	*3
6	IN1	- 0.3 to (V _{CC})	V	*1
FIN1	GND	0	V	
7	OUT1	—	V	*2
8	GND	0	V	
9	V _{cc}	0 to 3.0	V	
10	V _{cc}	0 to 3.0	V	
11	GND	0	V	
12	OUT2	—	V	*2
FIN2	GND	0	V	

注) *1 : RF signal input pin. Do not apply DC current.

*2 : RF signal output pin. Do not apply DC current.

*3 : Same as GND pin

2007-02-27		
Established	Revised	

	<h1>Product Standards</h1>	AN26210A	
		Total Pages	Page
		26	7

■ Absolute Maximum Ratings

A No.	Parameter	Symbol	Rating	Unit	Notes
1	Supply voltage	V_{CC}	3.0	V	*1
2	Supply current	I_{CC}	18	mA	—
3	Power dissipation	P_D	37.2	mW	*2
4	Operating ambient temperature	T_{opr}	-20 to +85	°C	*3
5	Storage temperature	T_{stg}	-40 to +125	°C	*3

Notes) *1 : The values under the condition not exceeding the above absolute maximum ratings and the power dissipation.

*2 : The power dissipation shown is the value at $T_a = 85^\circ\text{C}$ for the independent (unmounted) IC package.

When using this IC, refer to the P_D - T_a diagram of the package standard page 4 and use under the condition not exceeding the allowable value.

*3 : Except for the power dissipation, operating ambient temperature, and storage temperature, all ratings are for $T_a = 25^\circ\text{C}$.

■ Operating supply voltage range

Parameter	Symbol	Range	Unit	Notes
Supply voltage range	V_{CC}	2.70 to 2.95	V	*

Notes) * : The values under the condition not exceeding the above absolute maximum ratings and the power dissipation

2007-02-27		
Established	Revised	

	<h1>Product Standards</h1>	AN26210A	
		Total Pages	Page
		26	8

■ Electrical Characteristics at $V_{CC} = 2.85\text{ V}$

Notes) All parameters are specified under $T_a = 25^\circ\text{C} \pm 2^\circ\text{C}$ unless otherwise specified.

B No.	Parameter	Symbol	Test Circuit	Conditions	Limits			Unit	Notes
					Min	Typ	Max		
DC electrical characteristics									
DC-1	Supply current HG (2.1 GHz)	IccHa	1	V_{CC} current at 2.1 GHz High-Gain mode No input signal	—	4.5	6.0	mA	—
DC-2	Supply current HG (800 MHz)	IccHb	1	V_{CC} current at 800 MHz High-Gain mode No input signal	—	4.5	6.0	mA	—
DC-3	Supply current LG (2.1 GHz)	IccLa	1	V_{CC} current at 2.1 GHz Low-Gain mode No input signal	—	0.1	10	μA	—
DC-4	Supply current LG (800 MHz)	IccLb	1	V_{CC} current at 800MHz Low-Gain mode No input signal	—	0.1	10	μA	—
DC-5	Input voltage (High-Gain mode)	V _{IH}	1	$V_{IH} = V_{CC} \times 0.90$	2.57	2.85	—	V	—
DC-6	Input voltage (Low-Gain mode)	V _{IL}	1	$V_{IL} = V_{CC} \times 0.14$	—	0.0	0.4	V	—
DC-7	SW current (High)	I _{IH}	1	Current at SW pin $V_{IH} = V_{CC}$	—	0.0	10	μA	—
DC-8	SW current (Low)	I _{IL}	1	Current at SW pin $V_{IL} = 0\text{ V}$	—	0.0	10	μA	—

2007-02-27		
Established	Revised	

	<h1>Product Standards</h1>	AN26210A	
		Total Pages	Page
		26	9

■ Electrical Characteristics (continued) at $V_{CC} = 2.85\text{ V}$

Note) All parameters are specified under $T_a = 25^\circ\text{C} \pm 2^\circ\text{C}$, $f_{RXa} = 2140\text{ MHz}$, $PRX = -30\text{ dBm}$, CW unless otherwise specified.

B No.	Parameter	Symbol	Test Circuit	Conditions	Limits			Unit	Notes
					Min	Typ	Max		
2.1 GHz : LNA AC electrical characteristics									
A-1	Power Gain HG	GHSa	1	High-Gain mode $f = 2150\text{ MHz}$, $PRX = -30\text{ dBm}$	15.0	17.0	18.5	dB	—
A-2	Power Gain LG	GLSa	1	Low-Gain mode $f = 2150\text{ MHz}$, $PRX = -20\text{ dBm}$	-6.5	-4.5	-1.0	dB	—
A-3	IIP3 +10 MHz offset HG	IIP3H1Sa	1	High-Gain mode $f1 = f_{RXa} + 10\text{ MHz}$ $f2 = f_{RXa} + 20\text{ MHz}$ Input 2 signals ($f1, f2$)	-2.0	2.5	—	dBm	—
A-4	IIP3 -10 MHz offset HG	IIP3H2Sa	1	High-Gain mode $f1 = f_{RXa} - 10\text{ MHz}$ $f2 = f_{RXa} - 20\text{ MHz}$ Input 2 signals ($f1, f2$)	-2.0	2.0	—	dBm	—
A-5	IIP3 -95 MHz offset HG	IIP3_2040 HSa	1	High-Gain mode $f1 = f_{RXa} - 190\text{ MHz}$ $PRX1 = -27\text{ dBm}$ $f2 = f_{RXa} - 100\text{ MHz}$ $PRX2 = -33\text{ dBm}$ Input 2 signals ($f1, f2$)	2.0	5.0	—	dBm	—
A-6	IIP3 -190 MHz offset HG	IIP3_1760 HSa	1	High-Gain mode $f1 = f_{RXa} - 190\text{ MHz}$ $PRX1 = -27\text{ dBm}$ $f2 = f_{RXa} - 380\text{ MHz}$ $PRX2 = -45\text{ dBm}$ Input 2 signals ($f1, f2$)	-1.5	1.5	—	dBm	—
A-7	Input P1dB TX undesired signal input HG	IP1dBHSa	1	High-Gain mode $f1 = 2170\text{ MHz}$, $PRX1 = -40\text{ dBm}$ $f2 = 2170\text{ MHz} - 190\text{ MHz}$ Input 2 signals ($f1, f2$)	-19	-12	—	dBm	—

2007-02-27		
Established	Revised	

	<h1>Product Standards</h1>	AN26210A	
		Total Pages	Page
		26	10

■ Electrical Characteristics (continued) at $V_{CC} = 2.85\text{ V}$

注) All parameters are specified under $T_a = 25^\circ\text{C} \pm 2^\circ\text{C}$, $f_{RXb} = 875\text{ MHz}$, $PRX = -30\text{ dBm}$, CW unless otherwise specified.

B No.	Parameter	Symbol	Test Circuit	Conditions	Limits			Unit	Notes
					Min	Typ	Max		
800 MHz : LNA AC electrical characteristics									
B-1	Power Gain HG	GHSb	2	High-Gain mode $f = 885\text{ MHz}$, $RRX = -30\text{ dBm}$	15.5	17.0	18.5	dB	—
B-2	Power Gain LG	GLSb	2	Low-Gain mode $f = 885\text{ MHz}$, $PRX = -20\text{ dBm}$	-6.5	-4.2	-1.0	dB	—
B-3	IIP3 +10 MHz offset HG	IIP3H1Sb	2	High-Gain mode $f_1 = f_{RXb} + 10\text{ MHz}$ $f_2 = f_{RXb} + 20\text{ MHz}$ Input 2 signals (f_1, f_2)	-6.5	2.0	—	dBm	—
B-4	IIP3 -10 MHz offset HG	IIP3H2Sb	2	High-Gain mode $f_1 = f_{RXb} - 10\text{ MHz}$ $f_2 = f_{RXb} - 20\text{ MHz}$ Input 2 signals (f_1, f_2)	-8.0	0.0	—	dBm	—
B-5	IIP3 -22.5 MHz offset HG	IIP3_857.5 HSb	2	High-Gain mode $f_1 = f_{RXb} - 45\text{ MHz}$ $PRX1 = -27\text{ dBm}$ $f_2 = f_{RXb} - 22.5\text{ MHz}$ $PRX2 = -47\text{ dBm}$ Input 2 signals (f_1, f_2)	7.5	12.5	—	dBm	—
B-6	IIP3 -45 MHz offset HG	IIP3_790 HSb	2	High-Gain mode $f_1 = f_{RXb} - 45\text{ MHz}$ $PRX1 = -27\text{ dBm}$ $f_2 = f_{RXb} - 90\text{ MHz}$ $PRX2 = -50\text{ dBm}$ Input 2 signals (f_1, f_2)	-5.5	0.0	—	dBm	—
B-7	Input P1dB TX undesired signal input HG	IP1dBHSb	2	High-Gain mode $f_1 = f_{RXb}$, $PRX1 = -40\text{ dBm}$ $f_2 = f_{RXb} - 45\text{ MHz}$ Input 2 signals (f_1, f_2)	-19	-14	—	dBm	—

2007-02-27		
Established	Revised	

	<h1>Product Standards</h1>	AN26210A	
		Total Pages	Page
		26	11

■ **Electrical Characteristics (Reference values for design) at $V_{CC} = 2.85\text{ V}$**

Note) •All parameters are specified under $T_a = 25^\circ\text{C} \pm 2^\circ\text{C}$, $f_{RXa} = 2\ 110\text{ MHz}, 2\ 140\text{ MHz}, 2\ 170\text{ MHz}$, $PRX = -30\text{ dBm}$, CW

•The characteristics listed below are reference values derived from the design of the IC and are not guaranteed by inspection.

If a problem does occur related to these characteristics, we will respond in good faith to user concerns.

B No.	Parameter	Symbol	Test Circuit	Conditions	Reference values			Unit	Notes
					Min	Typ	Max		
2.1 GHz : LNA AC electrical characteristics									
C-1	Power Gain HG	GHa	1	High-Gain mode $f = f_{RXa}$	15.0	17.0	18.5	dB	—
C-2	Power Gain LG	GLa	1	Low-Gain mode $f = f_{RXa}$, $PRX = -20\text{ dBm}$	-6.5	-4.5	-1.0	dB	—
C-3	Noise Figure HG	NFHa	1	High-Gain mode $f = f_{RXa}$	—	1.55	1.90	dB	*1
C-4	Noise Figure LG	NFLa	1	Low-Gain mode $f = f_{RXa}$	—	4.5	6.5	dB	—
C-5	IM2 HG	IM2_190 Ha	1	High-Gain mode $f1 = f_{RXa} - 190\text{ MHz}$ $PRX1 = -27\text{ dBm}$ $f2 = 190\text{ MHz}$, $PRX2 = -75\text{ dBm}$ Input 2 signals ($f1, f2$)	—	-120	-113	dBm	—
C-6	IM2 HG	IM2_4090 Ha	1	High-Gain mode $f1 = f_{RX} - 190\text{ MHz}$ $PRX1 = -27\text{ dBm}$ $f2 = 2f_{RX} - 190\text{ MHz}$ $PRX2 = -35\text{ dBm}$ Input 2 signals ($f1, f2$)	—	-100	-95	dBm	—
C-7	IIP3 +10 MHz offset HG	IIP3H1a	1	High-Gain mode $f1 = f_{RXa} + 10\text{ MHz}$ $f2 = f_{RXa} + 20\text{ MHz}$ Input 2 signals ($f1, f2$)	-2.0	2.5	—	dBm	—
C-8	IIP3 -10 MHz offset HG	IIP3H2a	1	High-Gain mode $f1 = f_{RXa} - 10\text{ MHz}$ $f2 = f_{RXa} - 20\text{ MHz}$ Input 2 signals ($f1, f2$)	-2.0	2.0	—	dBm	—
C-9	IIP3 -95 MHz offset HG	IIP3_2040 Ha	1	High-Gain mode $f1 = f_{RXa} - 190\text{ MHz}$ $PRX1 = -27\text{ dBm}$ $f2 = f_{RXa} - 100\text{ MHz}$ $PRX2 = -33\text{ dBm}$ Input 2 signals ($f1, f2$)	2.0	5.0	—	dBm	—
C-10	IIP3 -190 MHz offset HG	IIP3_1760 Ha	1	High-Gain mode $f1 = f_{RXa} - 190\text{ MHz}$ $PRX1 = -27\text{ dBm}$ $f2 = f_{RXa} - 380\text{ MHz}$ $PRX2 = -45\text{ dBm}$ Input 2 signals ($f1, f2$)	-1.5	1.5	—	dBm	—

Note) *1 : Connector & substrate loss (0.1dB) included

2007-02-27		
Established	Revised	

	<h1>Product Standards</h1>	AN26210A	
		Total Pages	Page
		26	12

■ Electrical Characteristics (Reference values for design ; continued) at $V_{CC} = 2.85\text{ V}$

Note) • All parameters are specified under $T_a = 25^\circ\text{C} \pm 2^\circ\text{C}$, $f_{RXa} = 2\ 110\text{ MHz}, 2\ 140\text{ MHz}, 2\ 170\text{ MHz}$, $PRX = -30\text{ dBm}$, CW

- The characteristics listed below are reference values derived from the design of the IC and are not guaranteed by inspection.
If a problem does occur related to these characteristics, we will respond in good faith to user concerns.

B No.	Parameter	Symbol	Test Circuit	Conditions	Reference values			Unit	Notes
					Min	Typ	Max		
2.1 GHz : LNA AC electrical characteristics									
C-11	IIP3 HG	IIP3_6040 Ha	1	High-Gain mode f1 = fRX - 190 MHz PRX1 = -27 dBm f2 = 2f1 + fRX, PRX2 = -25 dBm Input 2 signals (f1, f2)	1.5	5.5	—	dBm	—
C-12	Input P1dB TX undesired signal input HG	IP1dB Ha	1	Low-Gain mode f1 = fRX, PRX1 = -40 dBm f2 = fRX - 190 MHz Input 2 signals (f1, f2)	-19	-12	—	dBm	—
C-13	Reverse Isolation HG	ISOHa	1	High-Gain mode f = fRXa	—	-30	-20	dB	—
C-14	Reverse Isolation LG	ISOLa	1	Low-Gain mode f = fRXa	—	-4.5	-1.0	dB	—
C-15	Input Return Loss HG	S11Ha	1	High-Gain mode f = fRXa	8.5	9.5	—	dB	—
C-16	Input Return Loss LG	S11La	1	Low-Gain mode f = fRXa	8.5	9.5	—	dB	—
C-17	Output Return Loss HG	S22Ha	1	High-Gain mode f = fRXa	8.5	9.5	—	dB	—
C-18	Output Return Loss LG	S22La	1	Low-Gain mode f = fRXa	8.5	9.5	—	dB	—

2007-02-27		
Established	Revised	

	<h1>Product Standards</h1>	AN26210A	
		Total Pages	Page
		26	13

■ **Electrical Characteristics (Reference values for design ; continued) at $V_{CC} = 2.85\text{ V}$**

Note) •All characteristics are specified under $T_a = 25^\circ\text{C} \pm 2^\circ\text{C}$, $f_{RXb} = 875\text{ MHz}, 880\text{ MHz}, 885\text{ MHz}$, $PRX = -30\text{ dBm}$, CW

- The characteristics listed below are reference values derived from the design of the IC and are not guaranteed by inspection.
- If a problem does occur related to these characteristics, we will respond in good faith to user concerns.

B No.	Parameter	Symbol	Test Circuit	Conditions	Reference values			Unit	Notes
					Min	Typ	Max		
800 MHz : LNA AC electrical characteristics									
D-1	Power Gain HG	GHb	2	High-Gain mode $f = f_{RXb}$	15.5	17.0	18.5	dB	—
D-2	Power Gain LG	GLb	2	Low-Gain mode $f = f_{RXb}$ $PRX = -20\text{ dBm}$	-6.5	-4.2	-1.0	dB	—
D-3	Noise Figure HG	NFHb	2	High-Gain mode $f = f_{RXb}$	—	1.10	1.70	dB	*1
D-4	Noise Figure LG	NFLb	2	Low-Gain mode $f = f_{RXb}$	—	4.2	6.5	dB	—
D-5	IM2 HG	IM2_45 Hb	2	High-Gain mode $f1 = f_{RXb} - 45\text{ MHz}$ $PRX1 = -27\text{ dBm}$ $f2 = 45\text{ MHz}, PRX2 = -55\text{ dBm}$ Input 2 signals ($f1, f2$)	—	-94	-89	dBm	—
D-6	IM2 HG	IM2_1715 Hb	2	High-Gain mode $f1 = f_{RX} - 45\text{ MHz}$ $PRX1 = -27\text{ dBm}$ $f2 = 2f_{RX} - 45\text{ MHz}$ $PRX2 = -50\text{ dBm}$ Input 2 signals ($f1, f2$)	—	-78	-72	dBm	—
D-7	IIP3 +10 MHz offset HG	IIP3H1b	2	High-Gain mode $f1 = f_{RXb} + 10\text{ MHz}$ $f2 = f_{RXb} + 20\text{ MHz}$ Input 2 signals ($f1, f2$)	-6.5	2.0	—	dBm	—
D-8	IIP3 -10 MHz offset HG	IIP3H2b	2	High-Gain mode $f1 = f_{RXb} - 10\text{ MHz}$ $f2 = f_{RXb} - 20\text{ MHz}$ Input 2 signals ($f1, f2$)	-8.0	0.0	—	dBm	—
D-9	IIP3 -22.5 MHz offset HG	IIP3_857.5 Hb	2	High-Gain mode $f1 = f_{RXb} - 45\text{ MHz}$ $PRX1 = -27\text{ dBm}$ $f2 = f_{RXb} - 22.5\text{ MHz}$ $PRX2 = -47\text{ dBm}$ Input 2 signals ($f1, f2$)	7.5	12.5	—	dBm	—
D-10	IIP3 -45 MHz offset HG	IIP3_790 Hb	2	High-Gain mode $f1 = f_{RXb} - 45\text{ MHz}$ $PRX1 = -27\text{ dBm}$ $f2 = f_{RXb} - 90\text{ MHz}$ $PRX2 = -50\text{ dBm}$ Input 2 signals ($f1, f2$)	-5.5	0.0	—	dBm	—

Note) *1 : Connector & substrate loss (0.05dB) included

2007-02-27		
Established	Revised	

	<h1>Product Standards</h1>	AN26210A	
		Total Pages	Page
		26	14

■ Electrical Characteristics (Reference values for design ; continued) at $V_{CC} = 2.85\text{ V}$

Note) •All characteristics are specified under $T_a = 25^{\circ}\text{C} \pm 2^{\circ}\text{C}$, $f_{RXb} = 875\text{ MHz}, 880\text{ MHz}, 885\text{ MHz}$, $PRX = -30\text{ dBm}$

- The characteristics listed below are reference values derived from the design of the IC and are not guaranteed by inspection.
If a problem does occur related to these characteristics, we will respond in good faith to user concerns.

B No.	Parameter	Symbol	Test Circuit	Conditions	Reference values			Unit	Notes
					Min	Typ	Max		
800 MHz : LNA AC electrical characteristics									
D-11	IIP3 HG	IIP3_2550 Hb	2	High-Gain mode $f1 = f_{RX} - 45\text{ MHz}$ $PRX1 = -27\text{ dBm}$ $f2 = 2f1 + f_{RX}$ $PRX2 = -45\text{ dBm}$ Input 2 signals ($f1, f2$)	-7.0	-2.5	—	dBm	—
D-12	Input P1dB TX undesired signal input HG	IP1dB Hb	2	High-Gain mode $f1 = f_{RXb}$, $PRX1 = -40\text{ dBm}$ $f2 = f_{RXb} - 45\text{ MHz}$ Input 2 signals ($f1, f2$)	-19	-14	—	dBm	—
D-13	Reverse Isolation HG	ISOHb	2	High-Gain mode $f = f_{RXb}$	—	-24	-18	dB	—
D-14	Reverse Isolation LG	ISOLb	2	Low-Gain mode $f = f_{RXb}$	—	-4.2	-1.0	dB	—
D-15	Input Return Loss HG	S11Hb	2	High-Gain mode $f = f_{RXb}$	8.5	9.5	—	dB	—
D-16	Input Return Loss LG	S11Lb	2	Low-Gain mode $f = f_{RXb}$	8.5	9.5	—	dB	—
D-17	Output Return Loss HG	S22Hb	2	High-Gain mode $f = f_{RXb}$	8.5	9.5	—	dB	—
D-18	Output Return Loss LG	S22Lb	2	Low-Gain mode $f = f_{RXb}$	8.5	9.5	—	dB	—

2007-02-27		
Established	Revised	

	<h1>Product Standards</h1>	AN26210A	
		Total Pages	Page
		26	15

■ **Electrical Characteristics (Reference values for design ; continued) at $V_{CC} = 2.7\text{ V}$ to 2.95 V**

Note) •All characteristics are specified under $T_a = -20^\circ\text{C}$ to 85°C

- The characteristics listed below are reference values derived from the design of the IC and are not guaranteed by inspection. If a problem does occur related to these characteristics, we will respond in good faith to user concerns.

B No.	Parameter	Symbol	Test Circuit	Conditions	Reference values			Unit	Notes
					Min	Typ	Max		
DC electrical characteristics									
DCT-1	Supply current HG(2.1 GHz)	IccHTa	1	V_{CC} current at 2.1 GHz High Gain mode No input signal	—	4.5	6.8	mA	—
DCT-2	Supply current HG(800 MHz)	IccHTb	1	V_{CC} current at 800 MHz High Gain mode No input signal	—	4.5	6.8	mA	—
DCT-3	Supply current LG(2.1 GHz)	IccLTa	1	V_{CC} current at 2.1 GHz Low Gain mode No input signal	—	0.1	10	μA	—
DCT-4	Supply current LG(800 MHz)	IccLTb	1	V_{CC} current at 800 MHz Low Gain mode No input signal	—	0.1	10	μA	—

2007-02-27		
Established	Revised	

		Product Standards		AN26210A	
				Total Pages	Page
				26	16

■ **Electrical Characteristics (Reference values for design ; continued) at $V_{CC} = 2.7\text{ V}$ to 2.95 V**

Note) •All characteristics are specified under $T_a = -20^\circ\text{C}$ to 85°C , $f_{RXa} = 2\ 110\text{ MHz}$, $2\ 140\text{ MHz}$, $2\ 170\text{ MHz}$, $PRX = -30\text{ dBm}$, CW

- The characteristics listed below are reference values derived from the design of the IC and are not guaranteed by inspection.
- If a problem does occur related to these characteristics, we will respond in good faith to user concerns.

B No.	Parameter	Symbol	Test Circuit	Conditions	Limits			Unit	Notes
					Min	Typ	Max		
2.1 GHz : LNA AC electrical characteristics									
E-1	Power Gain HG	GHTa	1	High-Gain mode $f = f_{RXa}$	14.0	17.0	19.0	dB	—
E-2	Power Gain LG	GLTa	1	Low-Gain mode $f = f_{RXa}$, $PRX = -20\text{ dBm}$	-7.0	-4.5	-0.5	dB	—
E-3	Noise Figure HG	NFHTa	1	High-Gain mode $f = f_{RXa}$	—	1.55	2.25	dB	*1
E-4	Noise Figure LG	NFLTa	1	Low-Gain mode $f = f_{RXa}$	—	4.5	7.0	dB	—
E-5	IM2 HG	IM2_190 HTa	1	High-Gain mode $f1 = f_{RXa} - 190\text{ MHz}$ $PRX1 = -27\text{ dBm}$ $f2 = 190\text{ MHz}$, $PRX2 = -75\text{ dBm}$ Input 2 signals ($f1$, $f2$)	—	-120	-110	dBm	—
E-6	IM2 HG	IM2_4090 HTa	1	High-Gain mode $f1 = f_{RXa} - 190\text{ MHz}$ $PRX1 = -27\text{ dBm}$ $f2 = 2f_{RXa} - 190\text{ MHz}$ $PRX2 = -35\text{ dBm}$ Input 2 signals ($f1$, $f2$)	—	-100	-93	dBm	—
E-7	IIP3 +10 MHz offset HG	IIP3H1Ta	1	High-Gain mode $f1 = f_{RXa} + 10\text{ MHz}$ $f2 = f_{RXa} + 20\text{ MHz}$ Input 2 signals ($f1$, $f2$)	-5	2.5	—	dBm	—
E-8	IIP3 -10 MHz offset HG	IIP3H2Ta	1	High-Gain mode $f1 = f_{RXa} - 10\text{ MHz}$ $f2 = f_{RXa} - 20\text{ MHz}$ Input 2 signals ($f1$, $f2$)	-5	2.0	—	dBm	—
E-9	IIP3 -95 MHz offset HG	IIP3_2040 HTa	1	High-Gain mode $f1 = f_{RXa} - 190\text{ MHz}$ $PRX1 = -27\text{ dBm}$ $f2 = f_{RXa} - 100\text{ MHz}$ $PRX2 = -33\text{ dBm}$ Input 2 signals ($f1$, $f2$)	-0.5	5.0	—	dBm	—
E-10	IIP3 -190 MHz offset HG	IIP3_1760 HTa	1	High-Gain mode $f1 = f_{RXa} - 190\text{ MHz}$ $PRX1 = -27\text{ dBm}$ $f2 = f_{RXa} - 380\text{ MHz}$ $PRX2 = -45\text{ dBm}$ Input 2 signals ($f1$, $f2$)	-3.5	1.5	—	dBm	—

Note) *1 : Connector & substrate loss (0.1dB) included

2007-02-27		
Established	Revised	

	<h1>Product Standards</h1>	AN26210A	
		Total Pages	Page
		26	17

■ Electrical Characteristics (Reference values for design ; continued) at $V_{CC} = 2.7\text{ V}$ to 2.95 V

Note) •All characteristics are specified under $T_a = -20^\circ\text{C}$ to 85°C , $f_{RXa} = 2\ 110\text{ MHz}$, $2\ 140\text{ MHz}$, $2\ 170\text{ MHz}$, $PRX = -30\text{ dBm}$, CW

- The characteristics listed below are reference values derived from the design of the IC and are not guaranteed by inspection. If a problem does occur related to these characteristics, we will respond in good faith to user concerns.

B No.	Parameter	Symbol	Test Circuit	Conditions	Reference values			Unit	Notes
					Min	Typ	Max		
2.1 GHz : LNA AC electrical characteristics									
E-11	IIP3 HG	IIP3_6040 HTa	1	High-Gain mode f1 = fRXa - 190 MHz PRX1 = - 27 dBm f2 = 2f1 + fRXa PRX2 = - 25 dBm Input 2 signals (f1, f2)	- 0.5	5.5	—	dBm	—
E-12	Input P1dB HG	IP1dB HTa	1	High-Gain mode f1 = fRXa, PRX1 = - 40 dBm f2 = fRXa - 190 MHz Input 2 signals (f1, f2)	- 21	-12	—	dBm	—

2007-02-27		
Established	Revised	

	<h1>Product Standards</h1>	AN26210A	
		Total Pages	Page
		26	18

■ **Electrical Characteristics (Reference values for design : continued) at $V_{CC} = 2.7\text{ V}$ to 2.95 V**

Note) •All characteristics are specified under $T_a = -20^\circ\text{C}$ to 85°C , $f_{RXb} = 875\text{ MHz}$, 880 MHz , 885 MHz , $PRX = -30\text{ dBm}$, CW

•The characteristics listed below are reference values derived from the design of the IC and are not guaranteed by inspection.

If a problem does occur related to these characteristics, we will respond in good faith to user concerns.

B No.	Parameter	Symbol	Test Circuit	Conditions	Reference values			Unit	Notes
					Min	Typ	Max		
800 MHz : LNA AC electrical characteristics									
F-1	Power Gain HG	GHTb	2	High-Gain mode $f = f_{RXb}$	14.5	17.0	19.0	dB	—
F-2	Power Gain LG	GLTb	2	Low-Gain mode $f = f_{RXb}$, $PRX = -20\text{ dBm}$	-7.0	-4.2	-0.5	dB	—
F-3	Noise Figure HG	NFHTb	2	High-Gain mode $f = f_{RXb}$	—	1.10	2.00	dB	*1
F-4	Noise Figure LG	NFLTb	2	Low-Gain mode $f = f_{RXb}$	—	4.2	7.0	dB	—
F-5	IM2 HG	IM2_45 HTb	2	High-Gain mode $f1 = f_{RXb} - 45\text{ MHz}$ $PRX1 = -27\text{ dBm}$ $f2 = 45\text{ MHz}$, $PRX2 = -55\text{ dBm}$ Input 2 signals ($f1, f2$)	—	-94	-86	dBm	—
F-6	IM2 HG	IM2_1715 HTb	2	High-Gain mode $f1 = f_{RXb} - 45\text{ MHz}$ $PRX1 = -27\text{ dBm}$ $f2 = 2f_{RXb} - 45\text{ MHz}$ $PRX2 = -50\text{ dBm}$ Input 2 signals ($f1, f2$)	—	-78	-69	dBm	—
F-7	IIP3 +10 MHz offset HG	IIP3H1Tb	2	High-Gain mode $f1 = f_{RXb} + 10\text{ MHz}$ $f2 = f_{RXb} + 20\text{ MHz}$ Input 2 signals ($f1, f2$)	-8.5	2.0	—	dBm	—
F-8	IIP3 -10 MHz offset HG	IIP3H2Tb	2	High-Gain mode $f1 = f_{RXb} - 10\text{ MHz}$ $f2 = f_{RXb} - 20\text{ MHz}$ Input 2 signals ($f1, f2$)	-10	0.0	—	dBm	—
F-9	IIP3 -22.5 MHz offset HG	IIP3_857.5 HTb	2	High-Gain mode $f1 = f_{RXb} - 45\text{ MHz}$ $PRX1 = -27\text{ dBm}$ $f2 = f_{RXb} - 22.5\text{ MHz}$ $PRX2 = -47\text{ dBm}$ Input 2 signals ($f1, f2$)	4.5	12.5	—	dBm	—
F-10	IIP3 -45 MHz offset HG	IIP3_790 HTb	2	High-Gain mode $f1 = f_{RXb} - 45\text{ MHz}$ $PRX1 = -27\text{ dBm}$ $f2 = f_{RXb} - 90\text{ MHz}$ $PRX2 = -50\text{ dBm}$ Input 2 signals ($f1, f2$)	-8.0	0.0	—	dBm	—

Note) *1 : Connector & substrate loss (0.05dB) included

2007-02-27		
Established	Revised	

	<h1>Product Standards</h1>	AN26210A	
		Total Pages	Page
		26	19

■ **Electrical Characteristics (Reference values for design : continued) at $V_{CC} = 2.7\text{ V}$ to 2.95 V**

Note) •All characteristics are specified under $T_a = -20^\circ\text{C}$ to 85°C , $f_{RXb} = 875\text{ MHz}$, 880 MHz , 885 MHz , $PRX = -30\text{ dBm}$, CW

- The characteristics listed below are reference values derived from the design of the IC and are not guaranteed by inspection.
If a problem does occur related to these characteristics, we will respond in good faith to user concerns.

B No.	Parameter	Symbol	Test Circuit	Conditions	Reference values			Unit	Notes
					Min	Typ	Max		
800 MHz : LNA AC electrical characteristics									
F-11	IIP3 HG	IIP3_2550 HTb	2	High-Gain mode f1 = fRXb - 45 MHz PRX1 = - 27 dBm f2 = 2f1 + fRXb PRX2 = - 45 dBm Input 2 signals (f1, f2)	-10	-2.5	—	dBm	—
F-12	Input P1dB TX undesired signal input HG	IP1dB HTb	2	High-Gain mode f1 = fRXb, PRX1 = - 40 dBm f2 = fRXb - 45 MHz Input 2 signals (f1, f2)	-21	-14	—	dBm	—

2007-02-27		
Established	Revised	

	Product Standards	AN26210A	
		Total Pages	Page
		26	20

■ Control Pins Mode Table

Note) Control voltage range : See B No. DC-5 / B No. DC-6 at page 8

Pin No.	Descriptions	Voltage		Note
		Low	High	
3	High-Gain/Low-Gain Switching (Gain Control)	Low-Gain	High-Gain	
4	800 MHz/2.1 GHz Switching (LNA Select)	800 MHz	2.1 GHz	

■ Truth Table

Note) Control voltage range : See B No. DC-5 / B No. DC-6 at page 8

CNT1 (LNA Select) (Pin4)	CNT2 (Gain Control) (Pin3)	LNA2 (2.1 GHz)	LNA1 (800 MHz)	Mode
Low	High	Off	High-Gain	800 MHz High-Gain
Low	Low	Off	Low-Gain	800 MHz Low-Gain
High	High	High-Gain	Off	2.1 GHz High-Gain
High	Low	Low-Gain	Off	2.1 GHz Low-Gain

2007-02-27		
Established	Revised	

	<h1>Product Standards</h1>	AN26210A	
		Total Pages	Page
		26	21

■ Test Circuit Diagram

Note) External components : See page 23

• Test Circuit Diagram 1

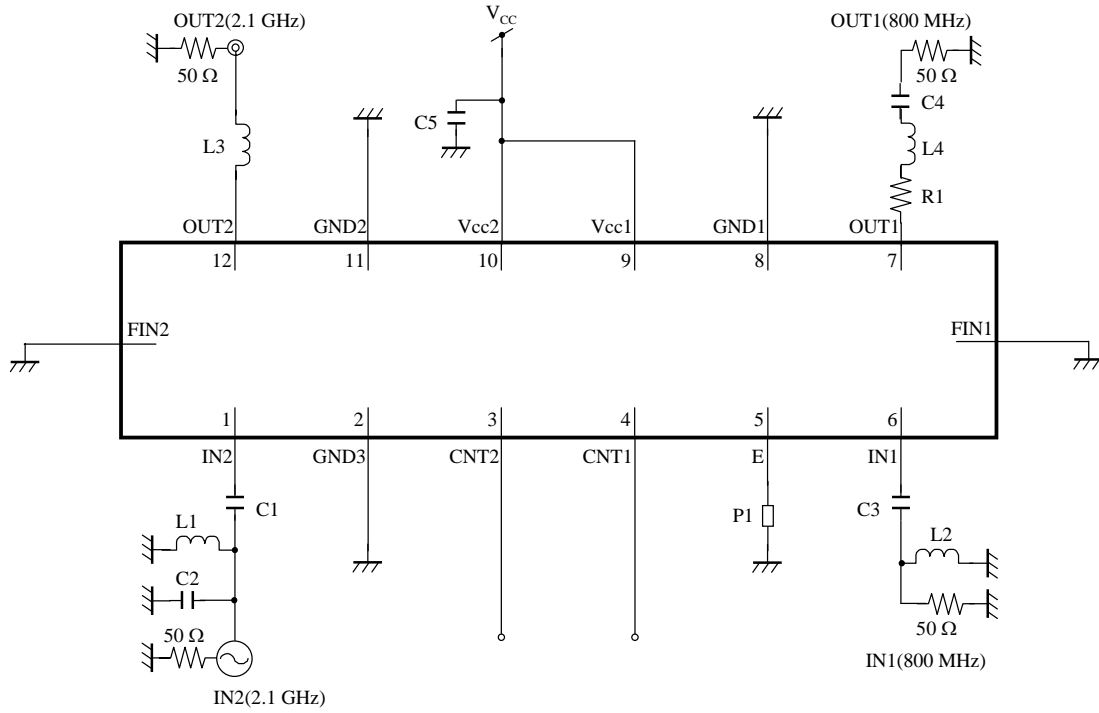

2007-02-27		
Established	Revised	

	<h1>Product Standards</h1>	AN26210A	
		Total Pages	Page
		26	22

■ Test Circuit Diagram (continued)

Note) External components : See page 23

• Test Circuit Diagram 2

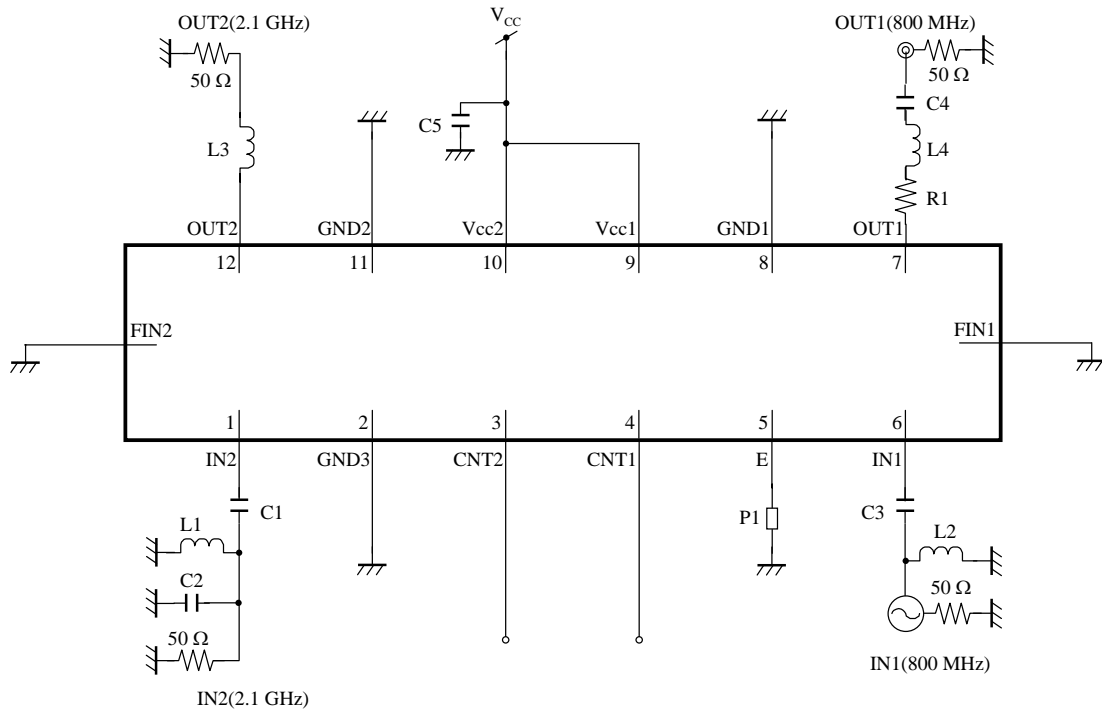

2007-02-27		
Established	Revised	

	<h1>Product Standards</h1>	AN26210A	
		Total Pages	Page
		26	23

■ Test Circuit Diagram (continued)

- External Components

Components	Size	Value	Part Number	Vendor
L1	1 005	1.5 nH	EKJRF1N5DF2	Panasonic
L2	1 005	10 nH	EKJRF10NJF2	Panasonic
L3	1 005	3.3 nH	EKJRF3N3DF2	Panasonic
L4	1 005	2.7 nH	EKJRF2N7DF2	Panasonic
C1	1 005	0.01 μ F	ECJ0EB1A103K	Panasonic
C2	1 005	2.4 pF	ECDG0E2R4B	Panasonic
C3	1 005	0.01 μ F	ECJ0EB1A103K	Panasonic
C4	1005	33 pF	ECJ0EC1H330J	Panasonic
C5	1 005	1 pF//10 pF//100 pF //1000 pF	ECJ0EB1H010C, others	Panasonic
R1	1608	12	ERJ3GEYJ120V	Panasonic
P1	Pattern	0.62 nH	Er = 2.7, W = 0.2 mm t = 0.6 mm, L = 0.95 mm	—

2007-02-27		
Established	Revised	

	<h1>Product Standards</h1>	AN26210A	
		Total Pages	Page
		26	24

■ Technical Data

- I/O block circuit diagrams and pin function descriptions

Pin No.	Voltage	Internal Circuit	Descriptions
1	0.85 V		2.1 GHz LNA input
2	0.0 V	—	GND
3	—		High-Gain/Low-Gain SW input Less than 0.40 V($V_{CC} \times 0.14$): Low-Gain mode More than 2.57 V($V_{CC} \times 0.90$): High-Gain mode
4	—		800 MHz/2.1 GHz SW input Less than 0.40 V($V_{CC} \times 0.14$): 800 MHz mode More than 2.57 V($V_{CC} \times 0.90$): 2.1 GHz mode
5	0.0 V		800 MHz LNA emitter
6	0.85 V	Same as 1	800 MHz LNA input

2007-02-27		
Established	Revised	

	<h1>Product Standards</h1>	AN26210A	
		Total Pages	Page
		26	25

■ Technical Data (continued)

- I/O block circuit diagrams and pin function descriptions (continued)

Pin No.	Voltage	Internal Circuit	Descriptions
FIN1	—		GND
7	—		800 MHz LNA output
8	0.0 V	—	GND
9	2.85 V		Voltage supply
10	2.85 V		Voltage supply

2007-02-27		
Established	Revised	

	<h1>Product Standards</h1>	AN26210A	
		Total Pages	Page
		26	26

■ Technical Data (continued)

- I/O block circuit diagrams and pin function descriptions

Pin No.	Voltage	Internal Circuit	Descriptions
11	0.0 V	—	GND
12	—	Same as 7	2.1 GHz LNA output
FIN2	—	Same as FIN1	GND

2007-02-27		
Established	Revised	