

- Features:
- Thick film resistor element
 - Zero ohm available
 - Auto-placement capability
 - Multiple circuit types available
 - Ideal SMD substitute for leaded networks

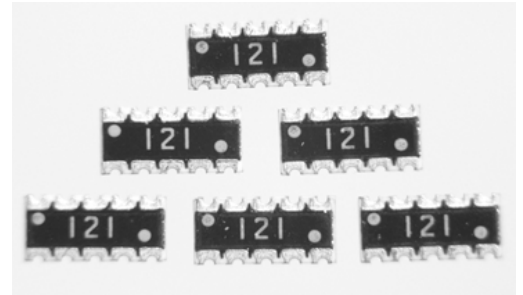

Electrical Specifications							
Type / Code / # of Elements / Circuit Type	Power Rating (per element) @ 70°C	Maximum Working Voltage (1)	Maximum Overload Voltage	Resistance Temperature Coefficient	Ohmic Range (Ω) and Tolerance		
					1%	2%	5%
RACF 16-4D	0.063W	50V	100V	±200 ppm/°C	1 - 1M	1 - 10M	1 - 10M
RACF 32-4D	0.125W	200V	400V	±200 ppm/°C	22 - 1M	-	10 - 1M
RACF 40-8M	0.063W	25V	50V	±200 ppm/°C	-	-	22 - 1M
RACF 64-8N	0.063W	50V	100V	±200 ppm/°C	-	-	22 - 1M
RACF 64-8R	0.063W	50V	100V	±200 ppm/°C	-	-	22 - 1M

(1) Lesser of \sqrt{PR} or maximum working voltage.
 Operating Temperature: RACF 16-4D: -55°C to +155°C
 All other types: -55°C to +125°C

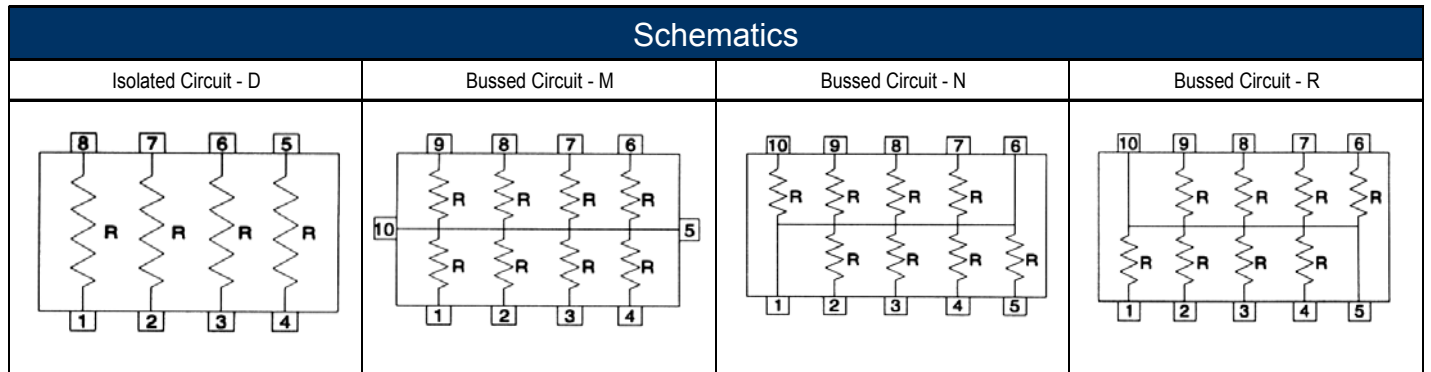

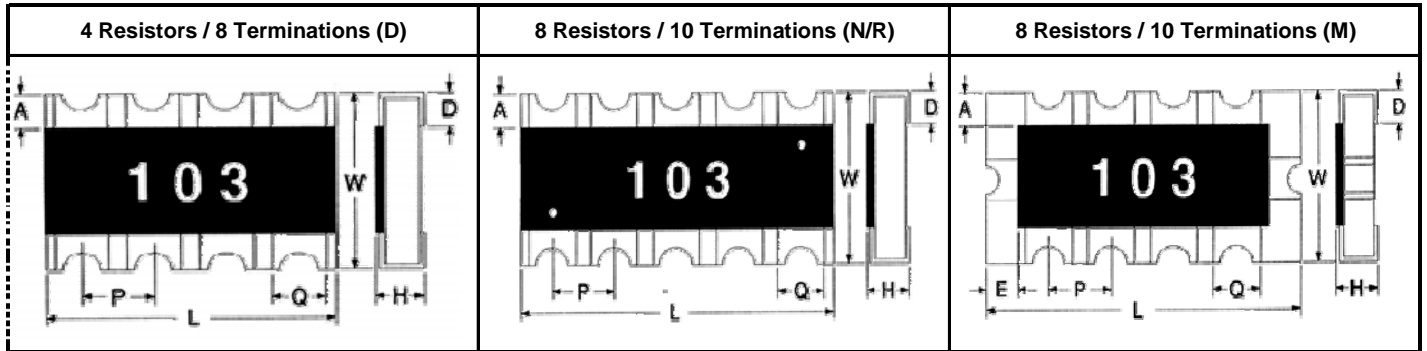

Mechanical Specifications									
Type / Code / # of Elements / Circuit Type	L Body Length	W Body Width	H Body Height	P Element Spacing	Q Termination Width	D Bottom Termination	A Top Termination	E End Termination	Units
RACF 16-4D	0.126 ± 0.008 3.20 ± 0.20	0.063 ± 0.006 1.60 ± 0.15	0.024 ± 0.006 0.60 ± 0.15	0.031 0.80	0.016 ± 0.008 0.40 ± 0.2	0.016 ± 0.008 0.40 ± 0.20	0.012 ± 0.008 0.30 ± 0.20	-	inches mm
RACF 32-4D	0.200 ± 0.008 5.08 ± 0.20	0.118 ± 0.008 3.00 ± 0.20	0.024 ± 0.004 0.60 ± 0.10	0.050 1.27	0.031 ± 0.004 0.80 ± 0.10	0.020 ± 0.008 0.50 ± 0.20	0.022 ± 0.008 0.55 ± 0.20	-	inches mm
RACF 40-8M	0.157 ± 0.008 4.00 ± 0.20	0.083 ± 0.008 2.10 ± 0.20	0.024 ± 0.004 0.60 ± 0.10	0.031 0.80	0.020 ± 0.008 0.50 ± 0.20	0.016 ± 0.008 0.40 ± 0.20	0.010 ± 0.008 0.25 ± 0.20	0.012 ± 0.008 0.30 ± 0.20	inches mm
RACF 64-8N	0.252 ± 0.008 6.40 ± 0.20	0.122 ± 0.008 3.10 ± 0.20	0.024 ± 0.004 0.60 ± 0.10	0.050 1.27	0.028 ± 0.008 0.70 ± 0.20	0.020 ± 0.008 0.50 ± 0.20	0.014 ± 0.006 0.35 ± 0.15	-	inches mm
RACF 64-8R	0.252 ± 0.008 6.40 ± 0.20	0.122 ± 0.008 3.10 ± 0.20	0.024 ± 0.004 0.60 ± 0.10	0.050 1.27	0.028 ± 0.008 0.70 ± 0.20	0.020 ± 0.008 0.50 ± 0.20	0.014 ± 0.006 0.35 ± 0.15	-	inches mm

Performance Characteristics	
Test	Test Results (JIS C 5202)
Load Life in Moisture	±3%
Temperature cycle	±1%
Load Life	±3%
Resistance to Soldering heat	±1%
Terminal Adhesion	±1%
Short Time Overload	±2%

Power Derating Curve:

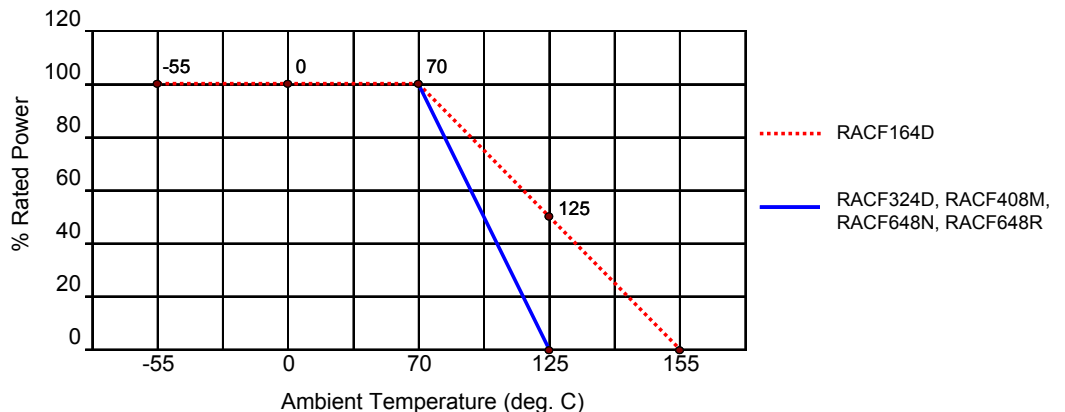

How to Order

SEI Type		Code	Number of Elements	Circuit Type	Nominal Resistance	Tolerance	Packaging			
RAC		16	4	D	10K	5%	R			
Type	Description	Code	Elements	Circuit Type	Tolerance		Types	Pkg Qty	Description	Code
RAC	Standard	16	4	D = Isolated	1%	E24	16	5,000	paper tape and reel	R
RACF	RoHS	32	8	M = Bussed	2%	E24	32, 40, 64	4,000	plastic tape and reel	
		40		N = Bussed	5%	E24				
		64		R = Bussed						

New part number format starting January 3rd, 2011:

How to Order

1	2	3	4	5	6	7	8	9	10	11	12	13	14
R	A	C	F	1	6	4	D	J	T	1	0	K	0
Product Series		Code	Power	Tolerance		Packaging				Resistance Value			
RACF	Concave RoHS	164D	0.063W	Code	Tol	Code	Description	Size	Quantity	Four characters with the multiplier used as the decimal holder.			
		324D	0.125W	F	1%	T	reel - paper tape	164D	5,000	1 ohm = 1R00			
		408M	0.063W	G	2%		reel - plastic tape	324D, 408M	4,000	100 Kohm = 100K			
		648N	0.063W	J	5%			648N, 648R		1 Mohm = 1M00			
		648R	0.063W										

D = Isolated
M, N, R = Bussed