

TWR-K40X256 Tower Module

User's Manual

Rev. 1.0

Table of Contents

1	TWR-K40X256 and TWR-K40X256-KIT Overview	4
1.1	Contents	5
1.2	Features	5
1.3	Getting Started	7
1.4	Reference Documents	7
2	Hardware Description	7
2.1	K40X256 Microcontroller	8
2.2	Clocking	9
2.3	System Power	10
2.3.1	RTC VBAT	10
2.4	Debug Interface	10
2.4.1	OSJTAG	10
2.4.2	Cortex Debug+ETM Connector	11
2.5	Infrared Port	11
2.6	Accelerometer	12
2.7	Potentiometer, Pushbuttons, LEDs	12
2.8	General Purpose Tower Plug-in (TWRPI) Socket	12
2.9	Touch Interface	13
2.10	Segment LCD	14
2.11	USB	14
2.12	Secure Digital Card Slot	14
2.13	External Bus Interface – FlexBus	15
3	Jumper Table	15
4	Input/Output Connectors and Pin Usage Table	16
5	Tower Elevator Connections	18

List of Figures

Figure 1. Freescale Tower System Overview	4
Figure 2. Callouts on front side of the TWR-K40X256	6
Figure 3. Front side of TWR-K40X256 with TWRPI-SLCD attached.....	6
Figure 4. Callouts on back side of the TWR-K40X256.....	7
Figure 5. TWR-K40X256 Block Diagram	8
Figure 6. External clock source circuitry	9
Figure 7. Infrared Port Implementation	12
Figure 8. Flexbus Connections for External Memory Port Sizes (CSCRn[BLS] = 1)	15

List of Tables

Table 1. MCG oscillator input selection resistor settings	10
Table 2. Cortex Debug+ETM Connector Pinout	11
Table 3. General Purpose TWRPI socket pinout	13
Table 4. Touch TWRPI socket pinout	13
Table 5. TWR-K40X256 Jumper Table	15
Table 6. I/O Connectors and Pin Usage Table.....	16
Table 7. TWR-K40X256 Primary Connector Pinout.....	18
Table 8. TWR-K40X256 Secondary Connector Pinout	19

Revision History

Revision	Date	Changes
1.0	Nov 9, 2010	Initial Release for PWA 700-26547 Rev A

1 TWR-K40X256 and TWR-K40X256-KIT Overview

The TWR-K40X256 is a Tower Controller Module compatible with the Freescale Tower System. It can function as a stand-alone, low-cost platform for the evaluation of the Kinetis K30 and K40 family of microcontroller (MCU) devices. The TWRPI-SLCD segment LCD daughter card is included as part of the TWR-K40X256.

The TWR-K40X256 features the Kinetis K40 low-power microcontroller based on the ARM® Cortex™-M4 architecture with USB 2.0 full-speed OTG and segment LCD display controllers. The K40X256 includes 256Kbytes of program flash storage and an additional 256Kbytes of FlexMemory non-volatile storage that can be used as additional program flash memory, data flash, or variable size/endurance EEPROM.

The TWR-K40X256 is available as a stand-alone product or as a kit (TWR-K40X256-KIT) with the Tower Elevator Modules (TWR-ELEV) and the Tower Serial Module (TWR-SER). The TWR-K40X256 can also be combined with other Freescale Tower peripheral modules to create development platforms for a wide variety of applications. Figure 1 provides an overview of the Freescale Tower System.

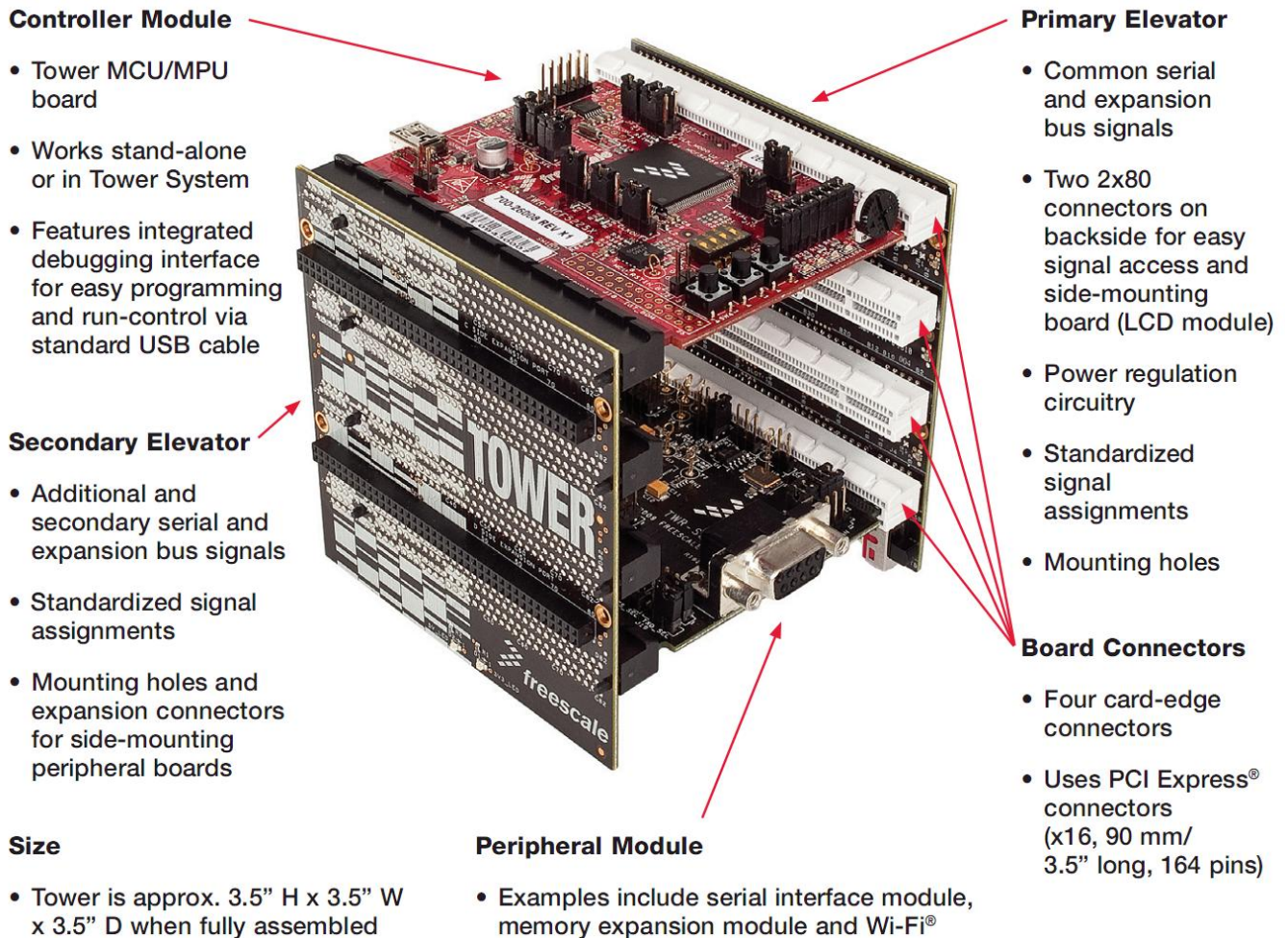

Figure 1. Freescale Tower System Overview

1.1 Contents

The TWR-K40X256 contents include:

- TWR-K40X256 board assembly
- Segment LCD Tower Plug-in module, TWRPI-SLCD
- 3ft USB cable
- Interactive DVD with software installers and documentation
- Quick Start Guide

The TWR-K40X256-KIT contains:

- TWR-K40X256 MCU module
- TWR-ELEV – Primary and Secondary Elevator Modules
- TWR-SER – Serial module including USB host/device/OTG, Ethernet, CAN, RS232 and RS485

1.2 Features

Figure 2, Figure 3 and Figure 4 show the TWR-K40X256 with some of the key features called out. The following list summarizes the features of the TWR-K40X256 Tower MCU Module:

- Tower compatible microcontroller module
- MK40X256VMD100: K40X256 in a 144 MAPBGA with 100MHz operation
- Touch and Segment LCD Tower Plug-in Socket
- Segment LCD Tower Plug-in module, TWRPI-SLCD
- General purpose Tower Plug-in (TWRPI) socket
- On-board JTAG debug circuit (OSJTAG) with virtual serial port
- Three axis accelerometer (MMA7660)
- Four (4) user-controllable LEDs
- Four (4) capacitive touch pads
- Two (2) user pushbutton switches
- Potentiometer
- Battery Holder for 20mm lithium battery (e.g. 2032, 2025)
- SD Card slot

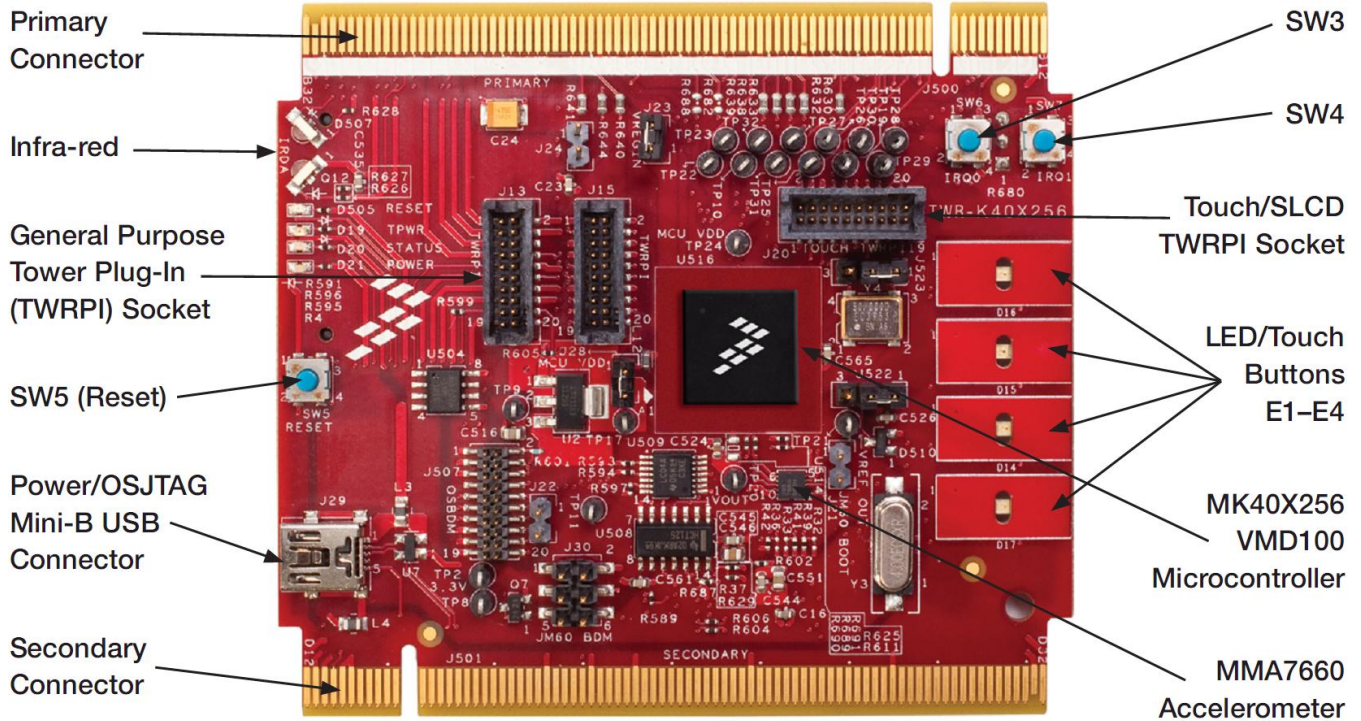

Figure 2. Callouts on front side of the TWR-K40X256

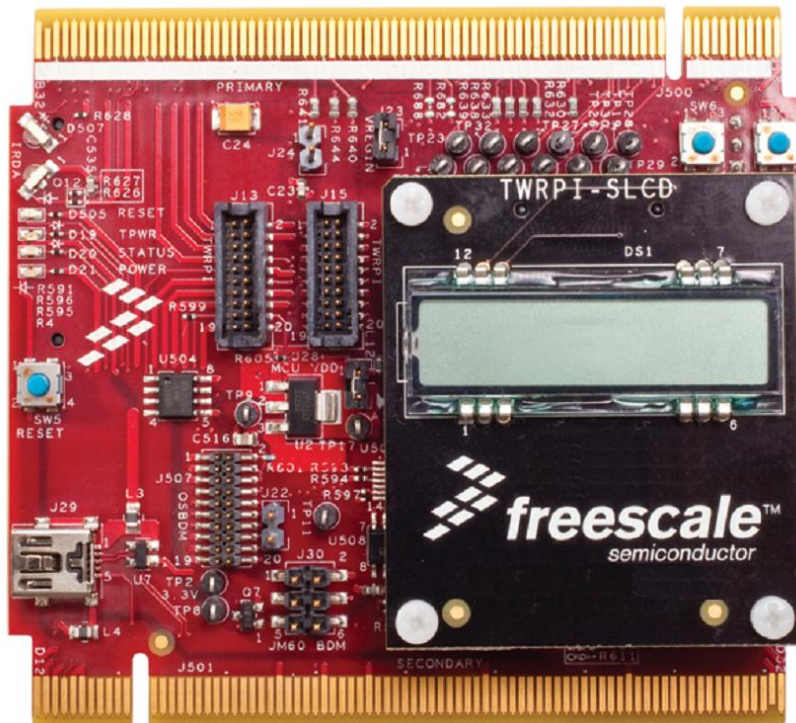

Figure 3. Front side of TWR-K40X256 with TWRPI-SLCD attached

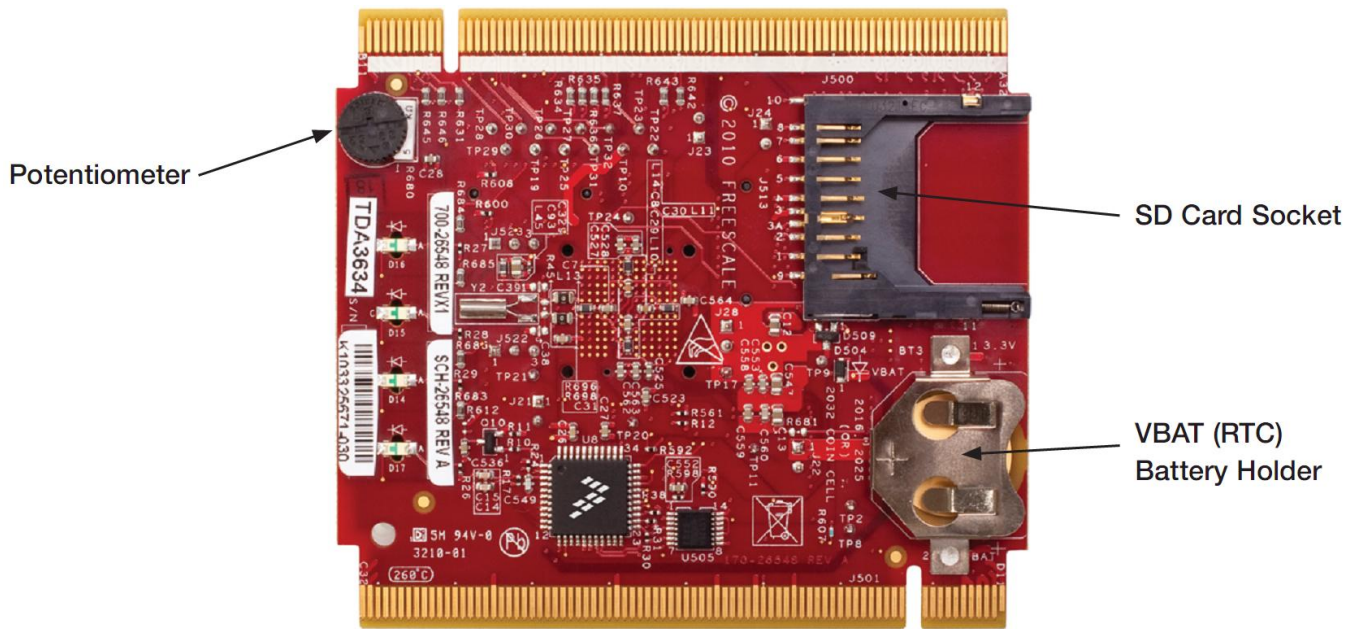

Figure 4. Callouts on back side of the TWR-K40X256

1.3 Getting Started

Follow the Quick Start Guide found printed in the TWR-K40X256 box or the interactive DVD for the list of recommended steps for getting started. There are also lab walk-through guides available on the tool support page for the TWR-K40X256: <http://www.freescale.com/TWR-K40X256>.

1.4 Reference Documents

The documents listed below should be referenced for more information on the Kinetis family, Tower System, and MCU Modules. These can be found in the documentation section of [freescale.com/TWR-K40X256](http://www.freescale.com/TWR-K40X256) or [freescale.com/kinetis](http://www.freescale.com/kinetis).

- *TWR-K40X256-QSG: Quick Start Guide*
- *TWR-K40X256-SCH: Schematics*
- *TWR-K40X256-PWA: Design Package*
- *TWRPI-SLCD-SCH: Schematics*
- *TWRPI-SLCD-PWA: Design Package*
- *K40 Family Product Brief*
- *K40 Family Reference Manual*
- *Kinetis Quick Reference User Guide (QRUG)*
- *Tower Configuration Tool*

2 Hardware Description

The TWR-K40X256 is a Tower Controller Module featuring the MK40X256VMD100—an ARM Cortex-M4 based microcontroller with segment LCD and USB 2.0 full-speed OTG controllers in a 144 MAPBGA package with a maximum core operating frequency of 100MHz. It is intended for use in the Freescale Tower System but can operate stand-alone. An on-board debug circuit, OSJTAG, provides a JTAG debug interface and a power supply input through a single USB mini-AB connector. Figure 5 shows a block diagram of the TWR-K40X256. The following sections describe the hardware in more detail.

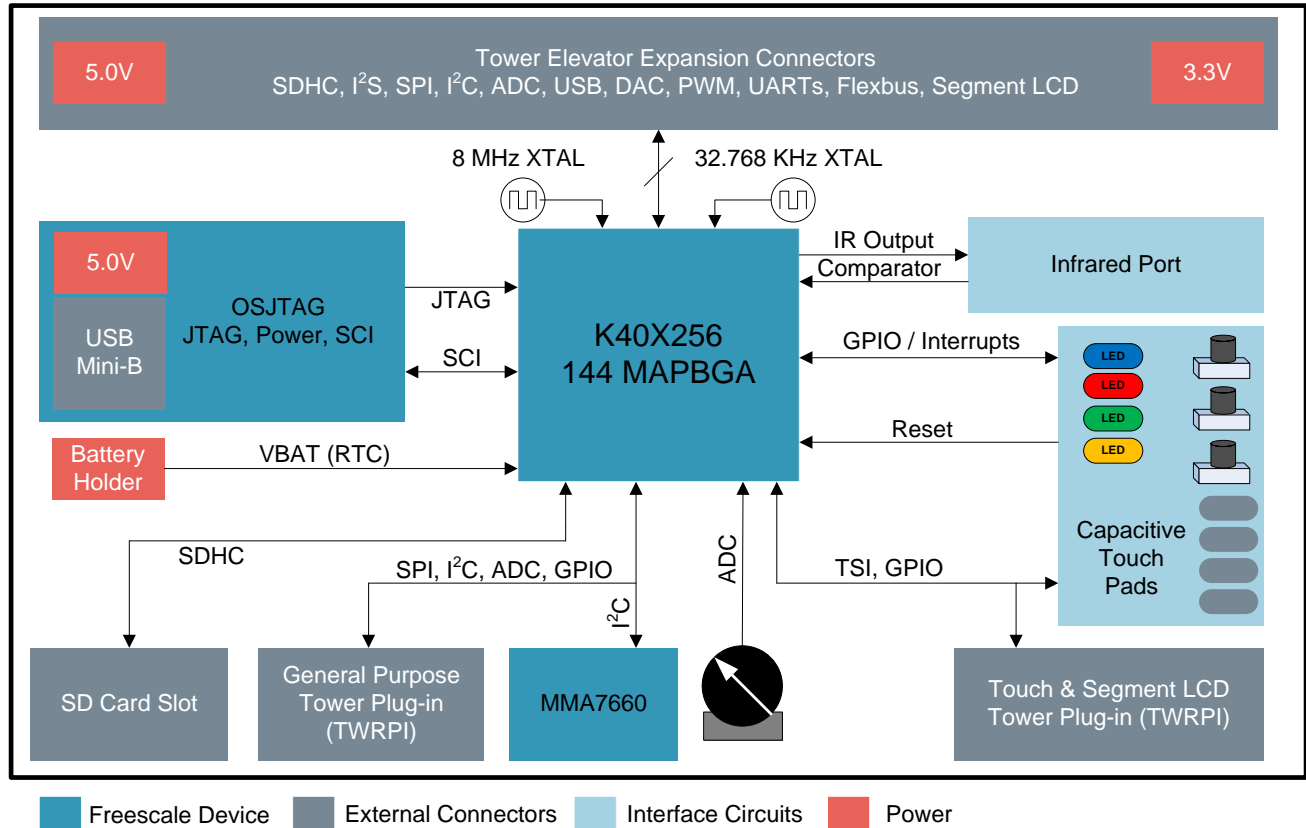

Figure 5. TWR-K40X256 Block Diagram

2.1 K40X256 Microcontroller

The TWR-K40X256 module features the MK40X256VMD100. The K40 microcontroller family is part of the Kinetis portfolio of devices built around an ARM Cortex-M4 core. Refer to the *K40 Family Product Brief* and the *K40 Family Reference Manual* for comprehensive information on the MK40X256VMD100 device. The key features are listed here:

- 32-bit ARM Cortex-M4 core with DSP instructions
- 100MHz maximum core operating frequency
- 144 MAPBGA, 13mm x 13mm, 1.0mm pitch package
- 1.71V – 3.6V operating voltage input range
- 256 Kbytes of program flash, 64 Kbytes of static RAM
- FlexMemory consisting of 256 Kbytes of FlexNVM (non-volatile flash memory that can be used as program flash, data flash, backup EEPROM of variable endurance and size) and 4 Kbytes of FlexRAM (RAM memory that can be used as traditional RAM, as high-endurance EEPROM storage, or flash programming acceleration RAM)
- External bus interface
- Power management controller with 10 different power modes
- Multi-purpose clock generator with PLL and FLL operation modes
- 16-bit SAR ADC, 12-bit DAC
- High-speed analog comparator with 6-bit DAC
- Programmable voltage reference

- USB full-speed/low-speed OTG/Host/Device controller with device charge detect
- SPI, I²C (w/ SMBUS support), UART (w/ ISO7816 and IrDA), CAN, I²S
- SD Host Controller (SDHC)
- GPIO with pin interrupt support, DMA request capability, digital glitch filtering
- Capacitive touch sensing inputs (TSI)
- LCD display driver supporting 3V and 5V glass, configurable frontplane and backplane pins, and segment failure detection
- Debug interfaces: JTAG, cJTAG, SWD
- Trace: TPIO, FPB, DWT, ITM, ETM, ETB

2.2 Clocking

The Kinetis MCUs start up from an internal digitally controlled oscillator (DCO). Software can enable one or two external oscillators if desired. The external oscillator for the Multipurpose Clock Generator (MCG) module can range from 32.768 KHz up to a 32 MHz crystal or ceramic resonator. The external oscillator for the Real Time Clock (RTC) module accepts a 32.768 kHz crystal.

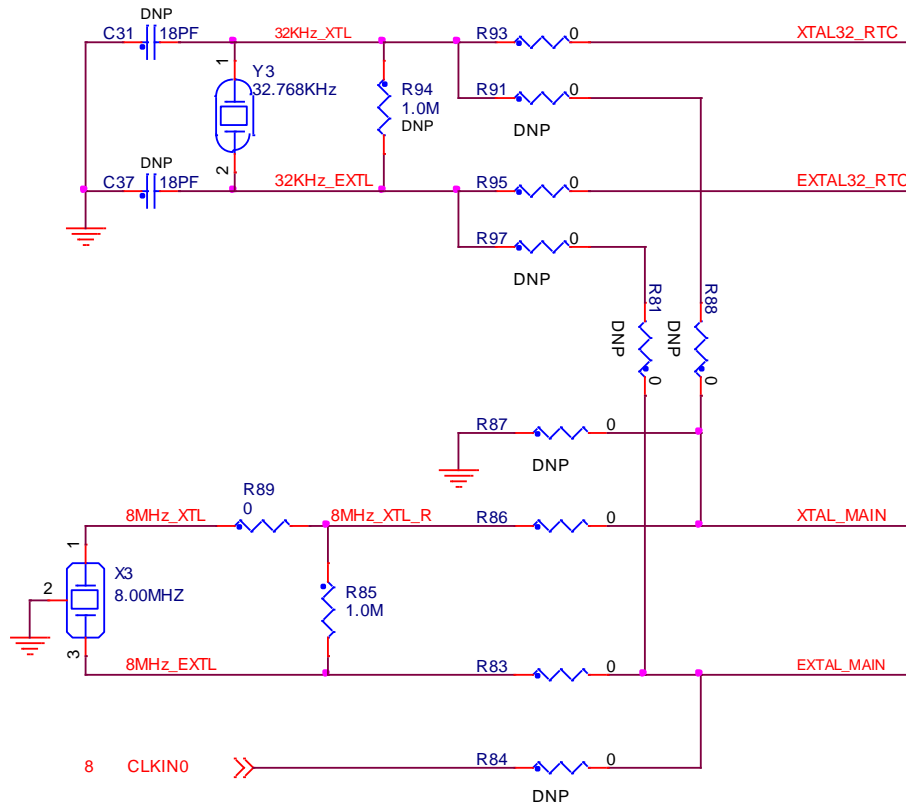

Figure 6. External clock source circuitry

The clocking circuitry on the TWR-K40X256 is shown on sheet 4 of the schematics and in Figure 6. An 8.0 MHz ceramic resonator with built-in load capacitors is the default external source for the MCG oscillator inputs (XTAL/EXTAL_MAIN). A 32.768 KHz crystal is connected to the RTC oscillator inputs by default. There are optional resistors (not populated by default) to allow for the MCG oscillator inputs to be routed from any one of the 8.0 MHz resonator, the 32.678 KHz crystal, or the clock input pin CLKIN0 from the Primary Connector (pin B24). Table 1 shows the resistor settings for each of the MCG oscillator input options.

Table 1. MCG oscillator input selection resistor settings

MCG Oscillator Input	R93	R91	R95	R97	R81	R88	R87	R86	R83	R84
8.0 MHz Resonator	X	—	X	—	—	—	—	X	X	—
32.768 KHz RTC Crystal	—	X	—	X	X	X	—	—	—	—
Clock Input from CLKIN0	X	—	X	—	—	—	X	—	—	X

"X" indicates that the resistor is installed; "—" indicates that the resistor is not populated. All resistor values are 0 ohm.

2.3 System Power

In stand-alone operation, the power source for the TWR-K40X256 module is derived from the 5.0V input from either the USB mini-B connector, J16, or the debug header, J14, when a shunt is placed on jumper J15. A low-dropout regulator provides a 3.3V supply from the 5.0V input voltage. Refer to sheet 5 of the TWR-K40X256 schematics for more details.

When installed into a Tower System, the TWR-K40X256 can be powered from either an on-board source or from another source in the assembled Tower System. If both the on-board and off-board sources are available, the TWR-K40X256 will default to the off-board source.

The 3.3V power supplied to the MCU is routed through a jumper, J11. The jumper shunt can be removed to allow for either 1) alternate MCU supply voltages to be injected or 2) the measurement of power consumed by the MCU.

2.3.1 RTC VBAT

The Real Time Clock (RTC) module on the K40 has two modes of operation, system power-up and system power-down. During system power-down, the RTC is powered from the backup power supply, VBAT. The TWR-K40X256 provides a battery holder for a coin cell battery that can be used as the VBAT supply. The holder can accept common 20mm diameter 3V lithium coin cell batteries (e.g. 2032, 2025). Refer to the description J12 in Table 5 "TWR-K40X256 Jumper Table" for more information.

2.4 Debug Interface

There are two debug interface options provided: the on-board OSJTAG circuit and an external Cortex Debug+ETM connector.

2.4.1 OSJTAG

An on-board MC9S08JM60 based Open Source JTAG (OSJTAG) circuit provides a JTAG debug interface to the K40X256. A standard USB A male to Mini-B male cable (provided) can be used for debugging via the USB connector, J16. The OSJTAG interface also provides a USB to serial bridge. Drivers for the OSJTAG interface are provided in the *P&E Micro Kinetis Tower Toolkit* (available on the included DVD).

Note: The port pins connected to the OSJTAG USB-to-serial bridge (PTD6 and PTD7) are also connected to the infrared interface. Refer to Table 6 "I/O Connectors and Pin Usage Table" and Table 5 "TWR-K40X256 Jumper Table" for more information.

2.4.2 Cortex Debug+ETM Connector

The Cortex Debug+ETM connector is a 20-pin (0.05") connector providing access to the SWD, SWV, JTAG, cJTAG, EzPort and ETM trace (4-bit) signals available on the K40 device. The pinout and K40 pin connections to the debug connector, J14, is shown in Table 2Table 2.

Table 2. Cortex Debug+ETM Connector Pinout

Pin	Function	TWR-K40X256 Connection
1	VTref	3.3V MCU supply (P3V3_MCU)
2	TMS / SWDIO	PTA3/SCIO_RTS_b/FTM0_CH0/JTAG_MS/SWD_DIO
3	GND	GND
4	TCK / SWCLK	PTA0/SCIO_CTS_b/FTM0_CH5/JTAG_CLK/SWD_CLK/EZP_CLK
5	GND	GND
6	TDO / SWO	PTA2/SCIO_TX/FTM0_CH7/JTAG_DO/TRACE_SWO/EZP_DO
7	Key	—
8	TDI	PTA1/SCIO_RX/FTM0_CH6/JTAG_DI/EZP_DI
9	GNDDetect	PTA4/FTM0_CH1/MS/NMI_b/EZP_CS_b
10	nRESET	RESET_b
11	Target Power	5V supply (via J15)
12	TRACECLK	PTA6/FTM0_CH3/FB_CLKOUT/TRACE_CLKOUT
13	Target Power	5V supply (via J15)
14	TRACEDATA[0]	PTA10/FTM2_CH0/FB_AD15/FTM2_QD_PHA/TRACE_D0
15	GND	GND
16	TRACEDATA[1]	PTA9/FTM1_CH1/FB_AD16/FTM1_QD_PHB/TRACE_D1
17	GND	GND
18	TRACEDATA[2]	PTA8/FTM1_CH0/FB_AD17/FTM1_QD_PHA/TRACE_D2
19	GND	GND
20	TRACEDATA[3]	PTA7/FTM0_CH4/FB_AD18/TRACE_D3

Note: Many of the trace signals connected to the debug connector are also connected elsewhere on the TWR-K40X256. Refer to Table 6 “I/O Connectors and Pin Usage Table” and Table 7 “TWR-K40X256 Primary Connector Pinout” for more information.

2.5 Infrared Port

An infrared transmit and receive interface is implemented as shown in Figure 7 below. The CMT_IRO pin directly drives an infrared diode. The receiver uses an infrared phototransistor connected to an on-chip analog comparator through a low-pass filter. Internal to the K40 device, the output of the analog comparator can be routed to a UART module for easier processing of the incoming data stream.

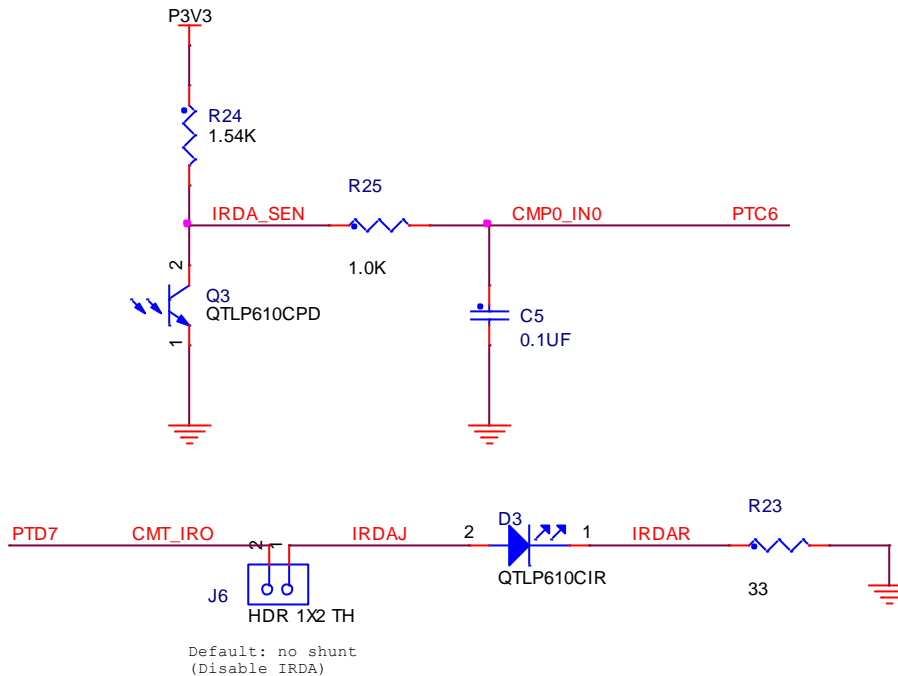

Figure 7. Infrared Port Implementation

Note: The port pins connected to the infrared interface (PTD6 and PTD7) are also connected to the OSJTAG USB-to-serial bridge. Refer to Table 6 “I/O Connectors and Pin Usage Table” and Table 5 “TWR-K40X256 Jumper Table” for more information.

2.6 Accelerometer

An MMA7660 digital accelerometer is connected to the K40 MCU through an I2C interface and a GPIO/IRQ signal. Refer to Table 6 “I/O Connectors and Pin Usage Table” for connection details.

2.7 Potentiometer, Pushbuttons, LEDs

The TWR-K40X256 features two pushbutton switches connected to GPIO/interrupt signals, one pushbutton connected to the master reset signal, four capacitive touch pad electrodes, four user-controllable LEDs, and a potentiometer connected to an ADC input signal. Refer to Table 6 “I/O Connectors and Pin Usage Table” for information about which port pins are connected to these features.

2.8 General Purpose Tower Plug-in (TWRPI) Socket

The TWR-K40X256 features a socket that can accept a variety of different Tower Plug-in modules featuring sensors, RF transceivers, and more. The General Purpose TWRPI socket provides access to I2C, SPI, IRQs, GPIOs, timers, analog conversion signals, TWRPI ID signals, reset, and voltage supplies. The pinout for the TWRPI Socket is defined in Table 3.

Refer to Table 6 “I/O Connectors and Pin Usage Table” for the specific K40 pin connections to the General Purpose TWRPI socket.

Table 3. General Purpose TWRPI socket pinout

Left-side 2x10 Connector		Right-side 2x10 Connector	
Pin	Description	Pin	Description
1	5V VCC	1	GND
2	3.3 V VCC	2	GND
3	GND	3	I2C: SCL
4	3.3V VDDA	4	I2C: SDA
5	VSS (Analog GND)	5	GND
6	VSS (Analog GND)	6	GND
7	VSS (Analog GND)	7	GND
8	ADC: Analog 0	8	GND
9	ADC: Analog 1	9	SPI: MISO
10	VSS (Analog GND)	10	SPI: MOSI
11	VSS (Analog GND)	11	SPI: SS
12	ADC: Analog 2	12	SPI: CLK
13	VSS (Analog GND)	13	GND
14	VSS (Analog GND)	14	GND
15	GND	15	GPIO: GPIO0/IRQ
16	GND	16	GPIO: GPIO1/IRQ
17	ADC: TWRPI ID 0	17	GPIO: GPIO2
18	ADC: TWRPI ID 1	18	GPIO: GPIO3
19	GND	19	GPIO: GPIO4/Timer
20	Reset	20	GPIO: GPIO5/Timer

2.9 Touch Interface

The touch sensing input (TSI) module of the Kinetis MCUs provides capacitive touch sensing detection with high sensitivity and enhanced robustness. Each TSI pin implements the capacitive measurement of an electrode.

The TWR-K40X256 provides two methods for evaluating the TSI module. There are four individual electrodes on-board the TWR-K40X256 that simulate pushbuttons. Additionally, twelve TSI signals are connected to a Touch Tower Plug-in (TWRPI) socket that can accept Touch TWRPI daughter cards that may feature keypads, rotary dials, sliders, etc.

The pinout for the Touch TWRPI socket is defined in Table 4. Refer to Table 6 “I/O Connectors and Pin Usage Table” for the specific K40 pin connections to the Touch TWRPI socket.

Table 4. Touch TWRPI socket pinout

Pin	Description
1	5V VCC
2	3.3 V VCC
3	Electrode 0
4	3.3V VDDA
5	Electrode 1
6	VSS (Analog GND)
7	Electrode 2

Pin	Description
8	Electrode 3
9	Electrode 4
10	Electrode 5
11	Electrode 6
12	Electrode 7
13	Electrode 8
14	Electrode 9
15	Electrode 10
16	Electrode 11
17	ADC: TWRPI ID 0
18	ADC: TWRPI ID 1
19	GND
20	Reset

2.10 Segment LCD

The segment LCD signals on the K40 devices are multiplexed with many other interface signals including several TSI signals that are accessible on the Touch TWRPI socket. Therefore, the Touch TWRPI socket on the TWR-K40X256 may also be used to evaluate the segment LCD controller of the K40 device. The TWRPI-SLCD daughter card included with the TWR-K40X256 plugs into the Touch TWRPI socket and provides a 28-segment LCD that can be driven directly by the K40 MCU. Refer to Table 6 “I/O Connectors and Pin Usage Table” for the segment LCD signals connection details.

Additionally, many more segment LCD signals are routed to the Secondary Connector on the TWR-K40X256 and can be accessed from another Tower module or on the expansion connectors of the Secondary Elevator. Refer to Table 8 “TWR-K40X256 Secondary Connector Pinout” for connection details.

2.11 USB

The K40X256 features a USB full-speed/low-speed OTG/Host/Device controller with built-in transceiver. The TWR-K40X256 routes the USB D+ and D- signals from the K40 MCU to the Primary Connector, allowing the connection to USB connectors or additional circuitry on a Tower peripheral module.

The TWR-SER module included as part of the TWR-K40X256-KIT provides a USB OTG/Host/Device interface with a mini-AB USB connector. There are many configuration options that can be selected to evaluate different USB modes of operation. By default, the TWR-SER is configured for USB Device operation. Please refer to the documentation included with the TWR-SER for more information on the configuration options.

2.12 Secure Digital Card Slot

A Secure Digital (SD) card slot is available on the TWR-K40X256 connected to the SD Host Controller (SDHC) signals of the K40 MCU. This slot will accept SD memory cards as well as Secure Digital Input Output (SDIO) cards. Refer to Table 6 “I/O Connectors and Pin Usage Table” for the SDHC signal connection details.

2.13 External Bus Interface – FlexBus

The K40 device features a multi-function external bus interface called the FlexBus interface controller capable of interfacing to slave-only devices. The FlexBus interface is not used directly on the TWR-K40X256. Instead, a subset of the FlexBus is connected to the Primary Connector so that the external bus can access devices on Tower peripheral modules.

The Primary Connector supports up to 20 address lines, 8 data lines, 2 chip-selects, read/write, and output enable signals. The SDHC signals of the K40 are multiplexed over the upper FlexBus address signals (FB_AD[27:23]), so a multiplexed mode of operation is used on the TWR-K40X256. An address latch is provided to de-multiplex the address and data signals prior to connecting them to the Primary Connector. Refer to sheet 8 of the TWR-K40X256 schematics for more details.

Note: The K40 Flexbus implementation provides an option for byte lane alignment. On the TWR-K40X256, FB_AD[7:0] are used for the data byte. Therefore, for proper operation software must set the CSCRx[BLS] bit to shift the data bus to the right byte lane. Refer to the FlexBus chapter in the *K40 Family Reference Manual* for more information.

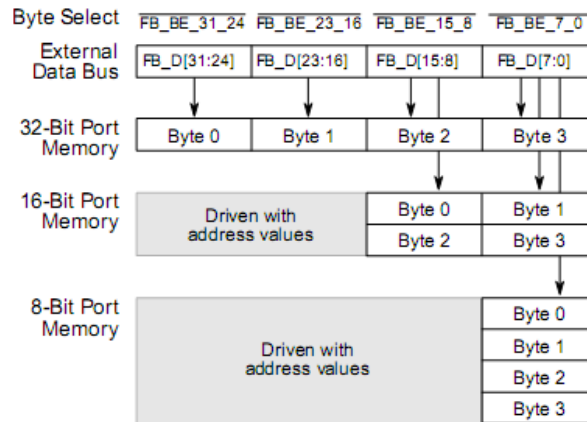

Figure 8. Flexbus Connections for External Memory Port Sizes (CSCRx[BLS] = 1)

3 Jumper Table

There are several jumpers on the TWR-K40X256 that provide configuration selection and signal isolation. Refer to the following table for details. The default installed jumper settings are shown in bold with asterisks.

Table 5. TWR-K40X256 Jumper Table

Jumper	Option	Setting	Description
J3	USB VREGIN Power Connection	*ON*	Connect USB0_VBUS from Primary Elevator (A57) to VREGIN
		OFF	Disconnect VREGIN from Primary Elevator
J5	Flexbus Address Latch Selection	1-2	Flexbus address latch disabled
		2-3	Flexbus address latch enabled
J6	Infrared Transmitter Connection	ON	Connect PTD7/CMT_IRO/UART0_TX to IR Transmitter (D3)
		OFF	Disconnect PTD7/CMT_IRO/UART0_TX from IR Transmitter (D3)
J11	MCU Power Connection	*ON*	Connect on-board 3.3V supply to MCU

		OFF	Isolate MCU from power supply (allows for external supply or power measurements)
J12	VBAT Power Selection	*1-2*	Connect VBAT to on-board 3.3V supply
		2-3	Connect VBAT to the higher voltage between on-board 3.3V supply or coin-cell supply
J13	OSJTAG Mode Selection	ON	OSJTAG bootloader mode (OSJTAG firmware reprogramming)
		OFF	Debugger mode
J15	JTAG Power Connection	ON	Connect on-board 5V supply to JTAG port (supports powering board from external JTAG probe)
		OFF	Disconnect on-board 5V supply from JTAG port

4 Input/Output Connectors and Pin Usage Table

The following table provides details on which K40X256 pins are using to communicate with the LEDs, switches, and other I/O interfaces onboard the TWR-K40X256.

Note: Some port pins are used in multiple interfaces on-board and many are potentially connected to off-board resources via the Primary and Secondary Connectors. Take care to avoid attempted simultaneous usage of mutually exclusive features.

Table 6. I/O Connectors and Pin Usage Table

Feature	Connection	Port Pin	Pin Function
OSJTAG USB-to-Serial Bridge	OSJTAG Bridge RX Data	PTD6	UART0_RX
	OSJTAG Bridge TX Data	PTD7	UART0_TX
SD Card Slot	SD Clock	PTE2	SDHC0_DCLK
	SD Command	PTE3	SDHC0_CMD
	SD Data0	PTE1	SDHC0_D0
	SD Data1	PTE0	SDHC0_D1
	SD Data2	PTE5	SDHC0_D2
	SD Data3	PTE4	SDHC0_D3
	SD Card Detect	PTA16	PTA16
	SD Write Protect	PTE27	PTE27
Infrared Port	IR Transmit	PTD7	CMT_IRO
	IR Receive	PTC6	CMPO_IN0
Pushbuttons	SW3 (IRQ0)	PTC5	PTC5
	SW4 (IRQ1)	PTC13	PTC13
	SW5 (RESET)	RESET_b	RESET_b
Touch Pads	E1 / Touch	PTB17	TSIO_CH10
	E2 / Touch	PTB18	TSIO_CH11
	E3 / Touch	PTB19	TSIO_CH12
	E4 / Touch	PTB16	TSIO_CH9
LEDs	E1 / Orange LED	PTC7	PTC7
	E2 / Yellow LED	PTC8	PTC8

	E3 / Green LED	PTC9	PTC9
	E4 / Blue LED	PTB11	PTB11
Potentiometer	Potentiometer (R71)	—	ADC1_DM1
SSI0 Access Header	SSI Header (J4 Pin 1)	PTA16	SSI0_RX_FS
	SSI Header (J4 Pin 2)	PTA13	SSI0_TX_FS
	SSI Header (J4 Pin 3)	PTA12	SSI0_TXD
	SSI Header (J4 Pin 4)	PTA15	SSI0_RXD
	SSI Header (J4 Pin 5)	PTA5	SSI_RX_BCLK
	SSI Header (J4 Pin 6)	PTA14	SSI0_TX_BCLK
	SSI Header (J4 Pin 7)	PTA17	SSI0_MCLK/SSI0_CLKIN
Accelerometer	I2C SDA	PTC11	I2C1_SDA
	I2C SCL	PTC10	I2C1_SCL
	IRQ	PTC12	PTC12
General Purpose TWRPI Socket	TWRPI AN0 (J8 Pin 8)	—	ADC0_DP0/ADC1_DP3
	TWRPI AN1 (J8 Pin 9)	—	ADC0_DM0/ADC1_DM3
	TWRPI AN2 (J8 Pin 12)	—	ADC1_DP0/ADC0_DP3
	TWRPI ID0 (J8 Pin 17)	—	ADC0_DP1
	TWRPI ID1 (J8 Pin 18)	—	ADC0_DM1
	TWRPI I2C SCL (J9 Pin 3)	PTC10	I2C1_SCL
	TWRPI I2C SDA (J9 Pin 4)	PTC11	I2C1_SDA
	TWRPI SPI MISO (J9 Pin 9)	PTB23	SPI2_SIN
	TWRPI SPI MOSI (J9 Pin 10)	PTB22	SPI2_SOUT
	TWRPI SPI SS (J9 Pin 11)	PTB20	SPI2_PCS0
	TWRPI SPI CLK (J9 Pin 12)	PTB21	SPI2_SCK
	TWRPI GPIO0 (J9 Pin 15)	PTC12	PTC12
	TWRPI GPIO1 (J9 Pin 16)	PTB9	PTB9
	TWRPI GPIO2 (J9 Pin 17)	PTB10	PTB10
	TWRPI GPIO3 (J9 Pin 18)	PTC5	PTC5
TWRPI GPIO4 (J9 Pin 19)	PTA5	PTA5	
Touch Pad / Segment LCD TWRPI Socket	Electrode 0 (J7 Pin 3)	PTB0	TSIO_CH0 / LCD_P0
	Electrode 1 (J7 Pin 5)	PTB1	TSIO_CH6 / LCD_P1
	Electrode 2 (J7 Pin 7)	PTB2	TSIO_CH7 / LCD_P2
	Electrode 3 (J7 Pin 8)	PTB3	TSIO_CH8 / LCD_P3
	Electrode 4 (J7 Pin 9)	PTC0	TSIO_CH13 / LCD_P20
	Electrode 5 (J7 Pin 10)	PTC1	TSIO_CH14 / LCD_P21
	Electrode 6 (J7 Pin 11)	PTC2	TSIO_CH15 / LCD_P22
	Electrode 7 (J7 Pin 12)	PTA4	TSIO_CH5
	Electrode 8 (J7 Pin 13)	PTB16	TSIO_CH9 / LCD_P12
	Electrode 9 (J7 Pin 14)	PTB17	TSIO_CH10 / LCD_P13
	Electrode 10 (J7 Pin 15)	PTB18	TSIO_CH11 / LCD_P14
	Electrode 11 (J7 Pin 16)	PTB19	TSIO_CH12 / LCD_P15
	TWRPI ID0 (J7 Pin 17)	—	ADC1_DP1

TWRPI ID1 (J7 Pin 18)
—
ADC1_DM0/ADC0_DM3

5 Tower Elevator Connections

The TWR-K40X256 features two expansion card-edge connectors that interface to the Primary and Secondary Elevator boards in a Tower system. The Primary Connector (comprised of sides A and B) and Secondary Connector (comprised of sides C and D) are both utilized by the TWR-K40X256. Table 7 provides the pinout for the Primary Connector. Table 8 provides the pinout for the Secondary Connector.

Table 7. TWR-K40X256 Primary Connector Pinout

Pin #	Side B		Pin #	Side A	
	Name	Usage		Name	Usage
B1	5V	5.0V Power	A1	5V	5.0V Power
B2	GND	Ground	A2	GND	Ground
B3	3.3V	3.3V Power	A3	3.3V	3.3V Power
B4	ELE_PS_SENSE	Elevator Power Sense	A4	3.3V	3.3V Power
B5	GND	Ground	A5	GND	Ground
B6	GND	Ground	A6	GND	Ground
B7	SDHC_CLK / SPI1_CLK	PTE2	A7	SCL0	PTC10
B8	SDHC_D3 / SPI1_CS1_b		A8	SDA0	PTC11
B9	SDHC_D3 / SPI1_CS0_b	PTE4	A9	GPIO9 / CTS1	PTC19
B10	SDHC_CMD / SPI1_MOSI	PTE1	A10	GPIO8 / SDHC_D2	PTE5
B11	SDHC_D0 / SPI1_MISO	PTE3	A11	GPIO7 / SD_WP_DET	PTE27
B12	ETH_COL		A12	ETH_CRS	
B13	ETH_RXER		A13	ETH_MDC	
B14	ETH_TXCLK		A14	ETH_MDIO	
B15	ETH_TXEN		A15	ETH_RXCLK	
B16	ETH_TXER		A16	ETH_RXDV	
B17	ETH_TXD3		A17	ETH_RXD3	
B18	ETH_TXD2		A18	ETH_RXD2	
B19	ETH_TXD1		A19	ETH_RXD1	
B20	ETH_TXD0		A20	ETH_RXD0	
B21	GPIO1 / RTS1	PTC18	A21	SSI_MCLK	PTA17
B22	GPIO2 / SDHC_D1	PTE0	A22	SSI_BCLK	PTA14
B23	GPIO3	PTE28	A23	SSI_FS	PTA13
B24	CLKIN0	PTA18	A24	SSI_RXD	PTA15
B25	CLKOUT1	PTE26	A25	SSI_TXD	PTA12
B26	GND	Ground	A26	GND	Ground
B27	AN7	PTB0	A27	AN3	PGA0_DP/ADC0_DP0/ADC1_DP3
B28	AN6	PTB1	A28	AN2	PGA0_DM/ADC0_DM0/ADC1_DM3
B29	AN5	PTB2	A29	AN1	PGA1_DP/ADC1_DP0/ADC0_DP3
B30	AN4	PTB3	A30	AN0	PGA1_DM/ADC1_DM0/ADC0_DM3
B31	GND	Ground	A31	GND	Ground
B32	DAC1	DAC1_OUT	A32	DAC0	DAC0_OUT
B33	TMR3	PTC5	A33	TMR1	PTA9
B34	TMR2	PTD6	A34	TMR0	PTA8
B35	GPIO4	PTB9	A35	GPIO6	PTB10
B36	3.3V	3.3V Power	A36	3.3V	3.3V Power
B37	PWM7	PTA2	A37	PWM3	PTC4
B38	PWM6	PTA1	A38	PWM2	PTC3
B39	PWM5	PTD5	A39	PWM1	PTC2
B40	PWM4	PTD4	A40	PWM0	PTC1
B41	CANRX0	PTE25	A41	RXD0	PTC14
B42	CANTX0	PTE24	A42	TXD0	PTC15
B43	1WIRE		A43	RXD1	PTC16

Pin #	Side B		Pin #	Side A	
	Name	Usage		Name	Usage
B44	SPI0_MISO	PTD3	A44	TXD1	PTC17
B45	SPI0_MOSI	PTD2	A45	VSS	VSSA
B46	SPI0_CS0_b	PTD0	A46	VDDA	VDDA
B47	SPI0_CS1_b	PTC3	A47	VREFA1	VREFH
B48	SPI0_CLK	PTD1	A48	VREFA2	VREFL
B49	GND	Ground	A49	GND	Ground
B50	SCL1	PTB2	A50	GPIO14	
B51	SDA1	PTB3	A51	GPIO15	
B52	GPIO5 / SD_CARD_DET	PTA16	A52	GPIO16	
B53	USB0_DP_PDOWN		A53	GPIO17	
B54	USB0_DM_PDOWN		A54	USB0_DM	USB0_DM
B55	IRQ_H	PTB5	A55	USB0_DP	USB0_DP
B56	IRQ_G	PTB5	A56	USB0_ID	
B57	IRQ_F	PTB6	A57	USB0_VBUS	VREGIN
B58	IRQ_E	PTB6	A58	TMR7	
B59	IRQ_D	PTB7	A59	TMR6	
B60	IRQ_C	PTB7	A60	TMR5	
B61	IRQ_B	PTB8	A61	TMR4	
B62	IRQ_A	PTB8	A62	RSTIN_b	RESET_b
B63	EBI_ALE / EBI_CS1_b	PTE6	A63	RSTOUT_b	RESET_b
B64	EBI_CS0_b	PTE7	A64	CLKOUT0	PTA6
B65	GND	Ground	A65	GND	Ground
B66	EBI_AD15	PTA10	A66	EBI_AD14	PTA24
B67	EBI_AD16	PTA9	A67	EBI_AD13	PTA25
B68	EBI_AD17	PTA8	A68	EBI_AD12	PTA26
B69	EBI_AD18	PTA7	A69	EBI_AD11	PTA27
B70	EBI_AD19	PTA29	A70	EBI_AD10	PTA28
B71	EBI_R/W_b	PTD15	A71	EBI_AD9	PTA29
B72	EBI_OE_b	PTA11	A72	EBI_AD8	PTD11
B73	EBI_D7	PTD12	A73	EBI_AD7	LATCH_FBA7
B74	EBI_D6	PTD13	A74	EBI_AD6	LATCH_FBA6
B75	EBI_D5	PTD14	A75	EBI_AD5	LATCH_FBA5
B76	EBI_D4	PTE8	A76	EBI_AD4	LATCH_FBA4
B77	EBI_D3	PTE9	A77	EBI_AD3	LATCH_FBA3
B78	EBI_D2	PTE10	A78	EBI_AD2	LATCH_FBA2
B79	EBI_D1	PTE11	A79	EBI_AD1	LATCH_FBA1
B80	EBI_D0	PTE12	A80	EBI_AD0	LATCH_FBA0
B81	GND	Ground	A81	GND	Ground
B82	3.3V	3.3V Power	A82	3.3V	3.3V Power

Table 8. TWR-K40X256 Secondary Connector Pinout

Pin #	Side D		Pin #	Side C	
	Name	Usage		Name	Usage
D1	5V	5.0V Power	C1	5V	5.0V Power
D2	GND	Ground	C2	GND	Ground
D3	3.3V	3.3V Power	C3	3.3V	3.3V Power
D4	ELE_PS_SENSE	Elevator Power Sense	C4	3.3V	3.3V Power
D5	GND	Ground	C5	GND	Ground
D6	GND	Ground	C6	GND	Ground
D7	SPI2_CLK		C7	SCL2	
D8	SPI2_CS1_b		C8	SDA2	
D9	SPI2_CS0_b		C9	GPIO25	
D10	SPI2_MOSI		C10	ULPI_STOP	
D11	SPI2_MISO		C11	ULPI_CLK	
D12	ETH_COL		C12	GPIO26	
D13	ETH_RXER		C13	ETH_MDC	

Pin #	Side D		Pin #	Side C	
	Name	Usage		Name	Usage
D14	ETH_TXCLK		C14	ETH_MDIO	
D15	ETH_TXEN		C15	ETH_RXCLK	
D16	GPIO18		C16	ETH_RXDV	
D17	GPIO19 / SDHC_D4		C17	GPIO27 / SDHC_D6	
D18	GPIO20 / SDHC_D5		C18	GPIO28 / SDHC_D7	
D19	ETH_TXD1		C19	ETH_RXD1	
D20	ETH_TXD0		C20	ETH_RXD0	
D21	ULPI_NEXT / USB1_DM		C21	ULPI_DATA0 / USB3_DM	
D22	ULPI_DIR / USB1_DP		C22	ULPI_DATA1 / USB3_DP	
D23	ULPI_DATA5 / USB2_DM		C23	ULPI_DATA2 / USB4_DM	
D24	ULPI_DATA6 / USB2_DP		C24	ULPI_DATA3 / USB4_DP	
D25	ULPI_DATA7		C25	ULPI_DATA4	
D26	GND	Ground	C26	GND	Ground
D27	LCD_HSYNC / LCD_P24	PTB9	C27	AN11	
D28	LCD_VSYNC / LCD_P25	PTB10	C28	AN10	
D29	AN13		C29	AN9	
D30	AN12		C30	AN8	
D31	GND	Ground	C31	GND	Ground
D32	LCD_CLK / LCD_P26	PTB11	C32	GPIO29	
D33	TMR11		C33	TMR9	
D34	TMR10		C34	TMR8	
D35	GPIO21		C35	GPIO30	
D36	3.3V	3.3V Power	C36	3.3V	3.3V Power
D37	PWM15		C37	PWM11	
D38	PWM14		C38	PWM10	
D39	PWM13		C39	PWM9	
D40	PWM12		C40	PWM8	
D41	CANRX1		C41	RXD2 / TSI0	
D42	CANTX1		C42	TXD2 / TSI1	
D43	GPIO22		C43	RTS2 / TSI2	
D44	LCD_OE / LCD_P27	PTB20	C44	CTS2 / TSI3	
D45	LCD_D0 / LCD_P0	PTC16	C45	RXD3 / TSI4	
D46	LCD_D1 / LCD_P1	PTC17	C46	TXD3 / TSI5	
D47	LCD_D2 / LCD_P2	PTC18	C47	RTS3 / TSI6	
D48	LCD_D3 / LCD_P3	PTC19	C48	CTS3 / TSI7	
D49	GND	Ground	C49	GND	Ground
D50	GPIO23		C50	LCD_D4 / LCD_P4	PTD0
D51	GPIO24		C51	LCD_D5 / LCD_P5	PTD1
D52	LCD_D12 / LCD_P12	PTC7	C52	LCD_D6 / LCD_P6	PTD2
D53	LCD_D13 / LCD_P13	PTC8	C53	LCD_D7 / LCD_P7	PTD3
D54	LCD_D14 / LCD_P14	PTC9	C54	LCD_D8 / LCD_P8	PTD4
D55	IRQ_P / SPI2_CS2_b		C55	LCD_D9 / LCD_P9	PTD5
D56	IRQ_O / SPI2_CS3_b		C56	LCD_D10 / LCD_P10	PTC4
D57	IRQ_N		C57	LCD_D11 / LCD_P11	PTC5
D58	IRQ_M		C58	TMR16	
D59	IRQ_L		C59	TMR15	
D60	IRQ_K		C60	TMR14	
D61	IRQ_J		C61	TMR13	
D62	IRQ_I		C62	LCD_D15 / LCD_P15	PTC12
D63	LCD_D18 / LCD_P18	PTC15	C63	LCD_D16 / LCD_P16	PTC13
D64	LCD_D19 / LCD_P19	PTB5	C64	LCD_D17 / LCD_P17	PTC14
D65	GND	Ground	C65	GND	Ground
D66	EBI_AD20 / LCD_P42		C66	EBI_BE_32_24_b / LCD_P28	PTB21
D67	EBI_AD21 / LCD_P43		C67	EBI_BE_23_16_b / LCD_P29	PTB22
D68	EBI_AD22 / LCD_P44		C68	EBI_BE_15_8_b / LCD_P30	PTB23
D69	EBI_AD23 / LCD_P45		C69	EBI_BE_7_0_b / LCD_P31	PTC3
D70	EBI_AD24 / LCD_P46		C70	EBI_TSIZE0 / LCD_P32	PTC10
D71	EBI_AD25 / LCD_P47		C71	EBI_TSIZE1 / LCD_P33	PTC11

Pin #	Side D		Pin #	Side C	
	Name	Usage		Name	Usage
D72	EBI_AD26 / LCD_P48		C72	EBI_TS_b / LCD_P34	
D73	EBI_AD27 / LCD_P49		C73	EBI_TBST_b / LCD_P35	
D74	EBI_AD28 / LCD_P50		C74	EBI_TA_b / LCD_P36	
D75	EBI_AD29 / LCD_P51		C75	EBI_CS4_b / LCD_P37	
D76	EBI_AD30 / LCD_P52		C76	EBI_CS3_b / LCD_P38	
D77	EBI_AD31 / LCD_P53		C77	EBI_CS2_b / LCD_P39	
D78	LCD_D20 / LCD_P20	PTB6	C78	EBI_CS1_b / LCD_P40	
D79	LCD_D21 / LCD_P21	PTB7	C79	GPIO31 / LCD_P41	
D80	LCD_D22 / LCD_P22	PTB8	C80	LCD_D23 / LCD_P23	
D81	GND	Ground	C81	GND	Ground
D82	3.3V	3.3V Power	C82	3.3V	3.3V Power