



Simplifying System Integration™

73S8014R/RN/RT 20SO Demo Board User Manual

July, 2008
Rev. 1.0
UM_8014_010

© 2008 Teridian Semiconductor Corporation. All rights reserved.
Teridian Semiconductor Corporation is a registered trademark of Teridian Semiconductor Corporation.
Simplifying System Integration is a trademark of Teridian Semiconductor Corporation.
All other trademarks are the property of their respective owners.

Teridian Semiconductor Corporation makes no warranty for the use of its products, other than expressly contained in the Company's warranty detailed in the Teridian Semiconductor Corporation standard Terms and Conditions. The company assumes no responsibility for any errors which may appear in this document, reserves the right to change devices or specifications detailed herein at any time without notice and does not make any commitment to update the information contained herein. Accordingly, the reader is cautioned to verify that this document is current by comparing it to the latest version on <http://www.teridian.com> or by checking with your sales representative.

Teridian Semiconductor Corp., 6440 Oak Canyon, Suite 100, Irvine, CA 92618
TEL (714) 508-8800, FAX (714) 508-8877, <http://www.teridian.com>

Table of Contents

1	Introduction	4
1.1	General	4
1.2	Safety and ESD Notes	4
1.3	Getting Started	5
1.4	Recommended Operating Conditions and Absolute Maximum Ratings	6
1.4.1	Recommended Operating Conditions	6
1.4.1	Absolute Maximum Ratings:	6
2	Design Considerations	9
2.1	General Layout Rules	9
2.2	Optimization for Compliance with NDS	9
3	Use of the Board: Hardware	10
3.1	Board Description: Jumpers, Switches and Test Points	10
3.2	73S8014R/RN/RT Pin Description	12
3.3	73S8014R/RN Pinout (SO20 – Top View)	14
3.4	73S8014RT PINOUT (20SO – Top View)	15
4	Appendix	16
6	Contact Information	23

1 Introduction

1.1 General

The TERIDIAN Semiconductor Corporation (TSC) 73S8014R/RN/RT Demo Board is a platform for evaluating the TERIDIAN 73S8014R/RN/RT smart card interface ICs. It incorporates either the 73S8014R, the 73S8014RN or the 73S8014RT integrated circuit, and it has been designed to operate either as a standalone platform (to be used in conjunction with an external microcontroller) or as a daughter card to be used in conjunction with the 73S12xxF evaluation platform. The three parts differ only slightly with regard to the control signals and the control function. These differences involve the VCC and the clock divider control signals. The 73S8014R and 73S8014RN use the $\overline{\text{CMDVCC}}$ and $5\text{V}/3\text{V}$ control signals to generate VCC (smart card supply voltage) at either 3V or 5V. The 73S8014RT redefines the $\overline{\text{CMDVCC}}$ pin as $\overline{\text{CMDVCC5}}$ and $5\text{V}/3\text{V}$ as CMDVCC3 . These redefined signals allow the selection of 5V, 3V and 1.8V for VCC. See the applicable data sheet for further detail. The 73S8014R uses the clock divider signals CLKDIV1 and CLKDIV2 to select between a divide by 1, 2, 4 and 8 for the smart card CLK output. The 73S8014RN and 73S8014RT have been redefined to select between divide by 1, 2, 4 and 6 to support NDS applications.

The board has been designed to comply with the NDS specification.

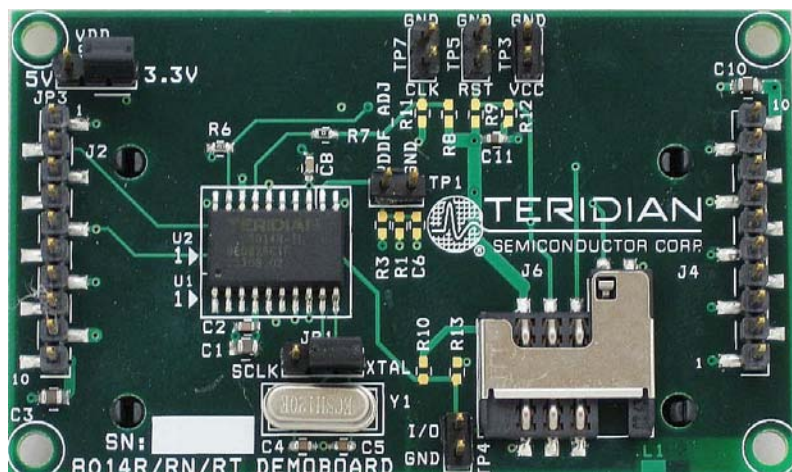

Figure 1: 73S8014R/RN/RT 20 SO Demo Board

1.2 Safety and ESD Notes

Connecting live voltages to the Demo Board system will result in potentially hazardous voltages on the boards.



Extreme caution should be taken when handling the Demo Boards after connection to live voltages!



The Demo Boards are ESD sensitive! ESD precautions should be taken when handling these boards!

1.3 Getting Started

The Figure 1.1 shows the basic connections of the Demo Board.

- Power Supplies: Apply 3.3V to pin 10 of J4 and 5V to pin 10 of J2.
- Control signals to the device can be connected through J2 and J4 (see Figure 1.1 and the electrical schematic Figure 4.1)
- Setting the clock frequency with an external clock source
 - Set JP1 to the SCLK setting
 - Apply clock source to pin 1 of J2
 - Apply 3.3V (1) or GND (0) to CLKDIV1 and CLKDIV2 pins allows the following:
 - CLKDIV1 = CLKDIV2 = 0
 - 73S8014R clock frequency = SCLK/8
 - 73S8014RN/RT clock frequency = SCLK/6
 - CLKDIV1 = 0, CLKDIV2 = 1 clock frequency = SCLK/4 (all)
 - CLKDIV1 = 1, CLKDIV2 = 0 clock frequency = SCLK (all)
 - CLKDIV1 = CLKDIV2 = 1 clock frequency = SCLK/2 (all)
- Setting the clock frequency using crystal Y1
 - Crystal included in the Demo Board is 12MHz (NDS applications can use 27MHz)
 - Set JP1 to XTAL position
 - Apply 3.3V (1) or GND (0) to CLKDIV1 and CLKDIV2 pins allows the following:
 - CLKDIV1 = CLKDIV2 = 0
 - ✓ 12MHz XTAL – clock frequency = 1.5MHz
 - ✓ 27MHz XTAL – clock frequency = 4.5MHz
 - CLKDIV1 = 0, CLKDIV2 = 1 clock frequency = 3MHz
 - ✓ 12MHz XTAL – clock frequency = 3MHz
 - ✓ 27MHz XTAL – clock frequency = 6.75MHz
 - CLKDIV1 = 1, CLKDIV2 = 0 – clock frequency = 12MHz
 - ✓ 12MHz XTAL – clock frequency = 12MHz
 - ✓ 27MHz XTAL – Illegal setting. Clock is not guaranteed to be stable as the device spec max CLK frequency is 20MHz.
 - CLKDIV1 = CLKDIV2 = 1 clock frequency = 6MHz
 - ✓ 12MHz XTAL – clock frequency = 6MHz
 - ✓ 27MHz XTAL - clock frequency = 13.5MHz

1.4 Recommended Operating Conditions and Absolute Maximum Ratings

1.4.1 Recommended Operating Conditions

Parameter	Rating
Supply Voltage V_{DD}	2.7 to 5.5 VDC
Supply Voltage V_{PC}	4.75 to 5.5 VDC (ISO-7816 and EMV applications) 4.85V to 5.5 VDC (NDS applications)
Ambient Operating Temperature	-40°C to +85°C
Input Voltage for Digital Inputs	0V to $V_{DD} + 0.3V$

1.4.1 Absolute Maximum Ratings:

Operation outside these rating limits may cause permanent damage to the device.

Parameter	Rating
Supply Voltage V_{DD}	-0.5 to 6.0 VDC
Supply Voltage V_{PC}	-0.5 to 6.0 VDC
Input Voltage for Digital Inputs	-0.3 to $(V_{DD}+0.5)$ VDC
Storage Temperature	-60 to 150°C
Pin Voltage	-0.3 to $(V_{DD}+0.5)$ VDC
Pin Current	±100mA
ESD Tolerance – Card interface pins	+/- 6kV
ESD Tolerance – Other pins	+/- 2kV

Note: ESD testing on Card pins is HBM condition, 3 pulses, each polarity referenced to ground.

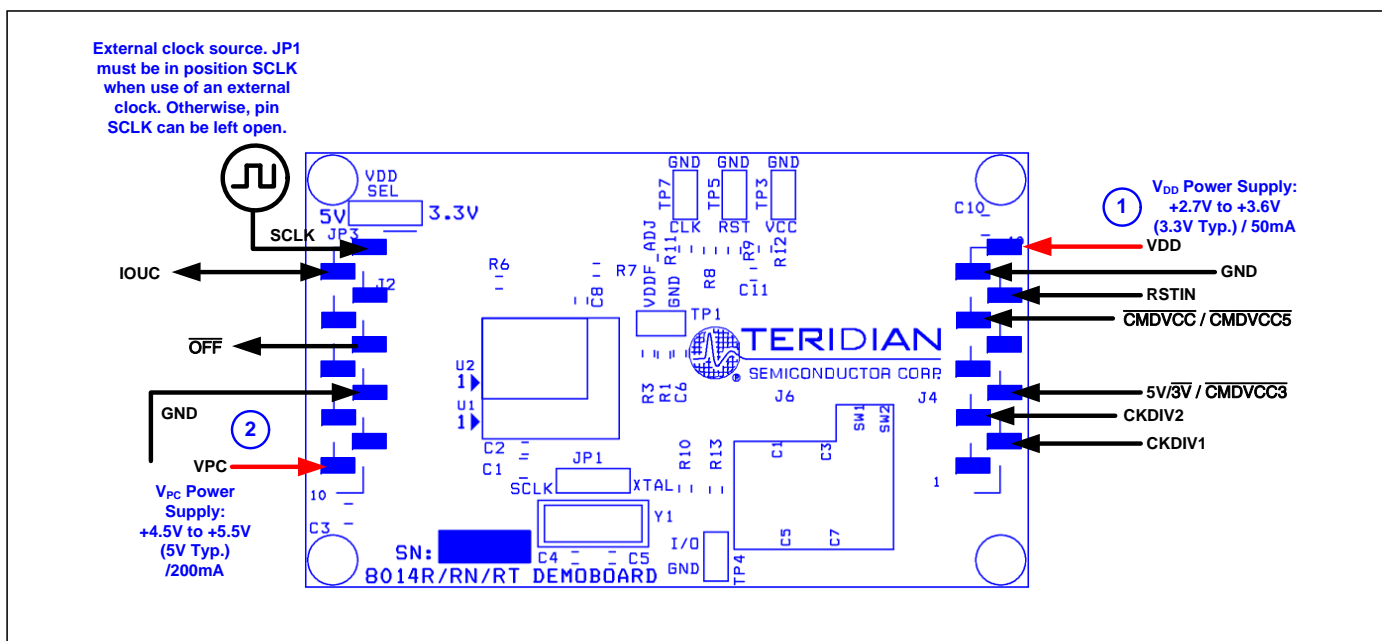

Figure 2: 73S8014R/RN/RT Demo Board: Basic Connections

2 Design Considerations

2.1 General Layout Rules

Keep the CLK signal as short as possible and with few bends in the trace. Keep route of the CLK trace to one layer (avoid vias to other plane). Keep CLK trace away from other traces especially RST and VCC. Filtering of the CLK trace is allowed for noise purpose. Up to 30pF to ground is allowed at the CLK pin of the smart card connector. Also, the 0Ω series resistor, R7, can be replaced for additional filtering (no more than 100Ω).

Keep the VCC trace as short as possible. Make trace a minimum of 0.5mm thick. Also, keep VCC away from other traces especially RST and CLK.

Keep RST trace away from VCC and CLK traces. Up to 30pF to ground is allowed for filtering.

Keep 0.1μF close to the VDD pin of the device and directly take other end to ground.

Keep 0.1μF and 10μF close to the VPC pin of the device and directly take other end to ground.

Keep 1.0μF close to the VCC pin of the smart card connector and directly take other end to ground

2.2 Optimization for Compliance with NDS

Default configuration of the Demo Board contains a 27pF capacitor (C12) from the CLK pin of the smart connector to ground and a 27pF capacitor (C9) from the RST pin of the smart connector to ground. These capacitors serve as filters for the CLK and RST signals in the case of long traces or test equipment perturbations. The capacitor on CLK reduces ringing on the trace, reduces coupling to other traces and slows down the edge of the CLK signal. The capacitor on RST helps the perturbation specification in a noisy environment. The filter capacitors can be useful in the EMV test environment and have no effect on NDS testing

C12 and C9 are represented on both the schematic and BOM. These capacitors are optional filter capacitors on the smart card lines CLK and RST, respectively for each card interface. These capacitors may be adjusted (value, not to exceed 30pF) or removed to optimize performance in each specific application (PCB, card clock frequency, compliance with applicable standards, etc.).

3 Use of the Board: Hardware

3.1 Board Description: Jumpers, Switches and Test Points

The items described in the following tables refer to the flags in Figure 2.1

Table 1: Demo Board Description

Item # (Figure 2.1)	Schematic & PCB Silk-print Reference	Name	Use
1	J2	Board 5V supply and host digital interface	Connector that gathers the 5V supply of the board, the 73S8014R/RN/RT data interface (IOUC), external clock (SCLK) and interrupt ($\overline{\text{OFF}}$) pins. Note that the external clock (SCLK) can be left open when JP1 is in position XTAL. Also note that the 5V power supply pin can be left open when JP2 is in position 3.3V (= support of 3V cards only).
2	JP3	VDD Select	Jumper to select the digital voltage, between 5V or 3.3V This setting defines the interfacing voltage with the host microcontroller. It also provides internal supply voltage for internal circuitry to the 73S8014R/RN/RT. The default setting is in the 3.3V position.
3 4 5 9	TP7 TP5 TP3 TP4	Test Points: CLK RST VCC I/O	2-pin test points for each respective smart card signal. The pin label name is the respective signal (i.e. VCC, CLK) and the other pin is GND.
6	J4	Board 3.3V supply and digital control signals	Connector that gathers the 3.3V supply of the board, the 73S8014R/RN/RT host control signal pins $\overline{\text{RSTIN}}$, $\overline{\text{CMDVCC}}$ / $\overline{\text{CMDVCC5}}$, $5\text{V}/3\text{V}$ / $\overline{\text{CMDVCC3}}$, CLKDIV2 and CLKDIV1. Note that the 3.3V power supply pin can be left open when JP3 is in position 5V.
7	TP1	PIN12 (VDDF_ADJ)	VDD voltage fault adjustment. Pin to the left is connected to the VDDF_ADJ pin of the 73S8014R/RN/RT and the pin to the right is GND. When either a resistor R3, or a resistor network R1 and R3 is populated on the board, it adjusts the VDD fault level that internally triggers a card deactivation sequence. By default, the resistors R1 and R3 are not connected. It provides a VDD fault level of 2.3V typical (internally set to the 73S8014R/RN/RT). Refers to the 73S8014R/RN/RT Data Sheet for further information about VDD fault level and determination of these resistor values.
8	J6	Smart Card Connector	SIM/SAM smart card format connector. Note that J6 is wired is parallel to the smart card connector J5 (underneath the PCB). No SIM/SAM should be inserted when using the credit-card size connector J5.
10	JP1	Clock selection.	Jumper to select between a crystal and external clock as the frequency reference to the device. The default setting is for a crystal.
11	J5	Smart Card Connector	Smart card connector. When inserting a card (credit card size format), contacts must face up.

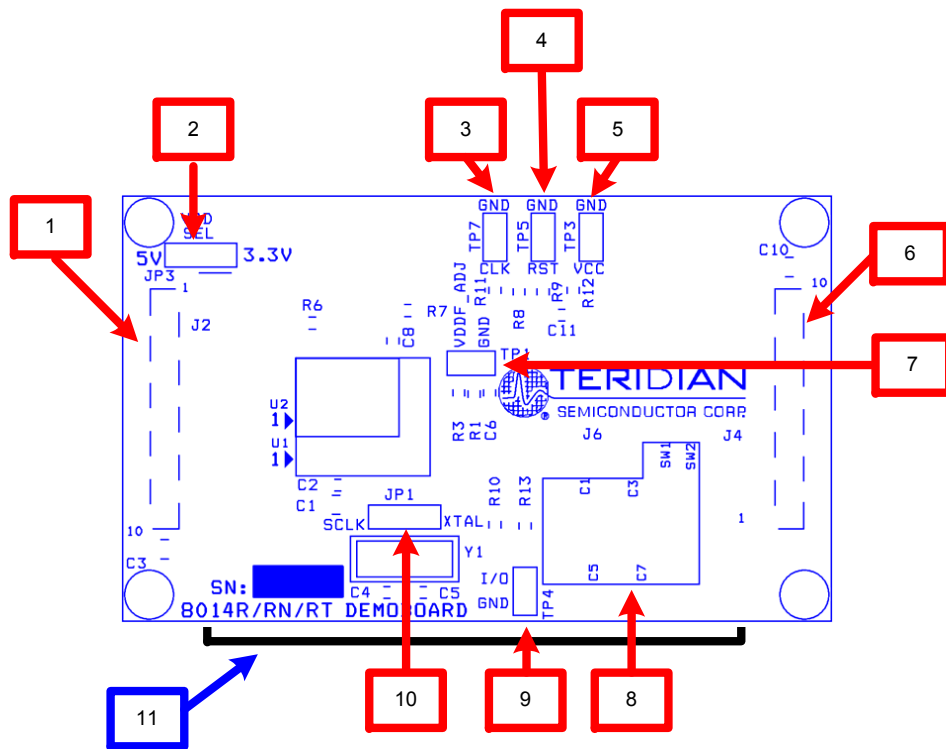

Figure 3: TERIDIAN 73S8014R/RN/RT Demo Board: Board Description

3.2 73S8014R/RN/RT Pin Description

Table 2: 73S8014R/RN/RT Pin Description: Card Interface

Name	Pin #	Description
I/O	14	Card I/O: Data signal to/from card. Includes a pull-up resistor to V_{CC} .
RST	15	Card reset: provides reset (RST) signal to card.
CLK	17	Card clock: provides clock signal (CLK) to card. The rate of this clock is determined by crystal oscillator frequency or external clock input and CLKDIV selections.
PRES	19	Card Presence switch: active high indicates card is present. Should be tied to GND when not used, but it Includes a high-impedance pull-down resistor.
VCC	18	Card power supply – logically controlled by sequencer, output of LDO regulator. Requires an external filter capacitor to the card GND.
GND	16	Card ground

Table 0: 73S8014R/RN/RT Pin Description: Miscellaneous and Outputs

Name	Pin #	Description
XTALIN	9	Crystal oscillator input: can either be connected to the crystal or driven as a source for the card clock.
XTALOUT	10	Crystal oscillator output: connected to the crystal. Left open if XTALIN is being used as external clock input.
VDDF_ADJ	12	V_{DD} fault threshold adjustment input: this pin can be used to adjust the V_{DDF} values (that controls deactivation of the card). Must be left open if unused.

Table 4: 73S8014R/RN/RT Pin Description: Power Supply and Ground

Name	Pin #	Description
VDD	13	System interface supply voltage and supply voltage for internal circuitry.
VPC	4	LDO regulator power supply source.
GND	8, 11	Digital ground.

Table 5: 73S8014R/RN/RT Pin Description: Microcontroller Interface

Name	Pin #	Description															
CMDVCC (R) CMDVCC% (RN/RT)	6	<p>(R) - Command VCC (negative assertion): Logic low on this pin causes the LDO regulator to ramp the V_{CC} supply to the card and initiates a card activation sequence, if a card is present.</p> <p>(RN/RT) - Logic low on one or both of these pins will cause the LDO to ramp the V_{CC} supply to the smart card and smart card interface to the value described in the following table</p> <table border="1"> <thead> <tr> <th>CMDVCC5</th> <th>CMDVCC3</th> <th>V_{CC} Output Voltage</th> </tr> </thead> <tbody> <tr> <td>0</td> <td>0</td> <td>1.8V</td> </tr> <tr> <td>0</td> <td>1</td> <td>5.0V</td> </tr> <tr> <td>1</td> <td>0</td> <td>3.0V</td> </tr> <tr> <td>1</td> <td>1</td> <td>LDO Off</td> </tr> </tbody> </table> <p>Note: In order to set VCC to 1.8V, both $\overline{\text{CMDVCC5}}$ and $\overline{\text{CMDVCC3}}$ must be asserted low within 400ns of each other. See the Data Sheet for further details.</p>	CMDVCC5	CMDVCC3	V _{CC} Output Voltage	0	0	1.8V	0	1	5.0V	1	0	3.0V	1	1	LDO Off
CMDVCC5	CMDVCC3	V _{CC} Output Voltage															
0	0	1.8V															
0	1	5.0V															
1	0	3.0V															
1	1	LDO Off															
5V/ $\overline{3V}$ (R) CMDVCC# (RN/RT)	7	<p>(R) - 5 volt / 3 volt card selection: Logic one selects 5 volts for V_{CC} and card interface, logic low selects 3 volt operation. When the part is to be used with a single card voltage, this pin should be tied to either GND or V_{DD}. However, it includes a high impedance pull-up resistor to default this pin high (selection of 5V card) when not connected.</p> <p>(RN/RT) See pin 6 above.</p>															
CLKDIV1 CLKDIV2	20 5	<p>Sets the divide ratio from the XTAL oscillator (or external clock input) to the card clock. These pins include pull-down resistors.</p> <table border="1"> <thead> <tr> <th>CLKDIV1</th> <th>CLKDIV2</th> <th>CLOCK RATE</th> </tr> </thead> <tbody> <tr> <td>0</td> <td>0</td> <td>XTALIN/8 (R) XTALIN/6 (RN/RT)</td> </tr> <tr> <td>0</td> <td>1</td> <td>XTALIN/4</td> </tr> <tr> <td>1</td> <td>1</td> <td>XTALIN/2</td> </tr> <tr> <td>1</td> <td>0</td> <td>XTALIN</td> </tr> </tbody> </table>	CLKDIV1	CLKDIV2	CLOCK RATE	0	0	XTALIN/8 (R) XTALIN/6 (RN/RT)	0	1	XTALIN/4	1	1	XTALIN/2	1	0	XTALIN
CLKDIV1	CLKDIV2	CLOCK RATE															
0	0	XTALIN/8 (R) XTALIN/6 (RN/RT)															
0	1	XTALIN/4															
1	1	XTALIN/2															
1	0	XTALIN															
OFF	1	Interrupt signal to the processor. Active Low - Multi-function indicating fault conditions or card presence. Open drain output configuration – It includes an internal 22kΩ pull-up to V _{DD} .															
RSTIN	2	Reset Input: This signal is the reset command to the card.															
I/OUC	3	System controller data I/O to/from the card. Includes a pull-up resistor to V _{DD} .															

3.3 73S8014R/RN Pinout (SO20 – Top View)

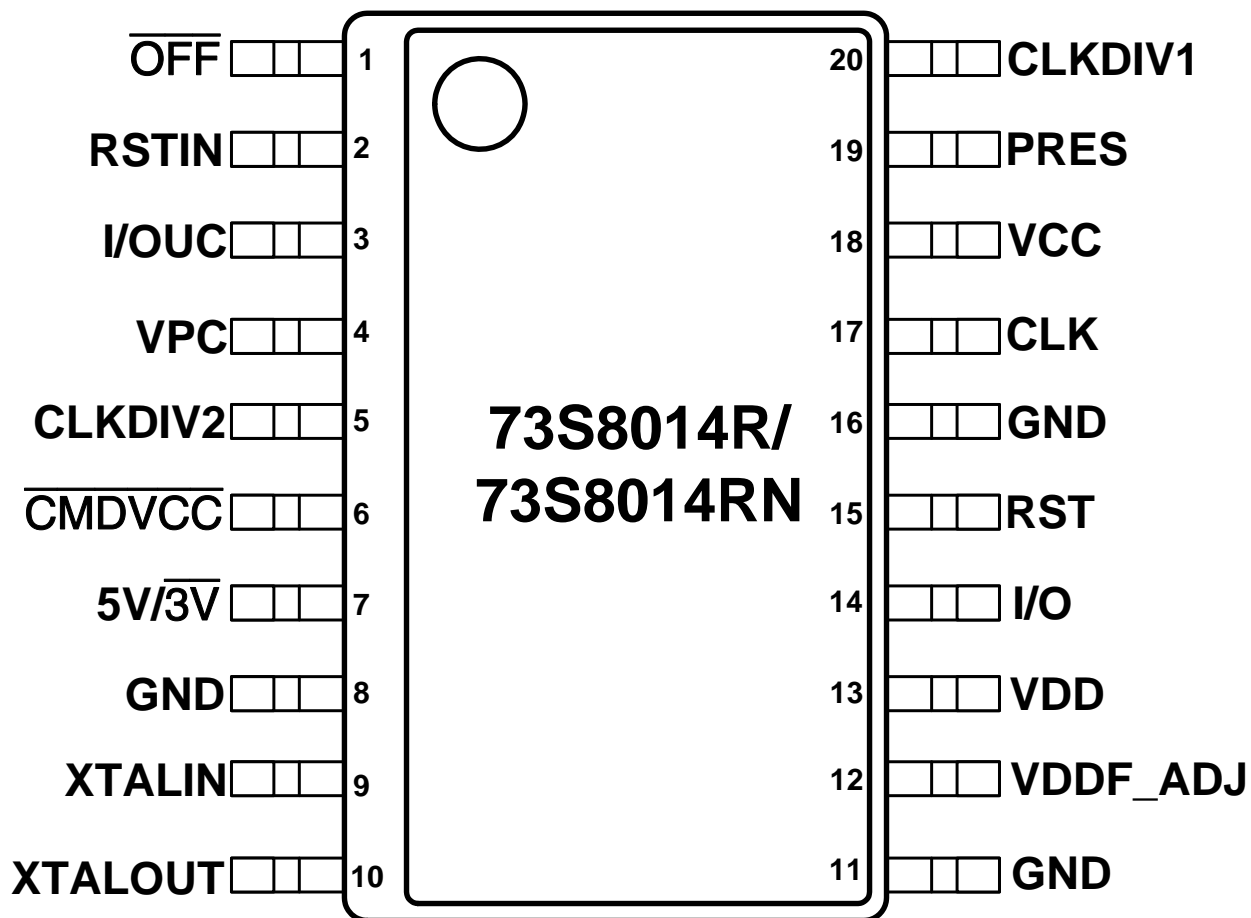

3.4 73S8014RT PINOUT (20SO – Top View)

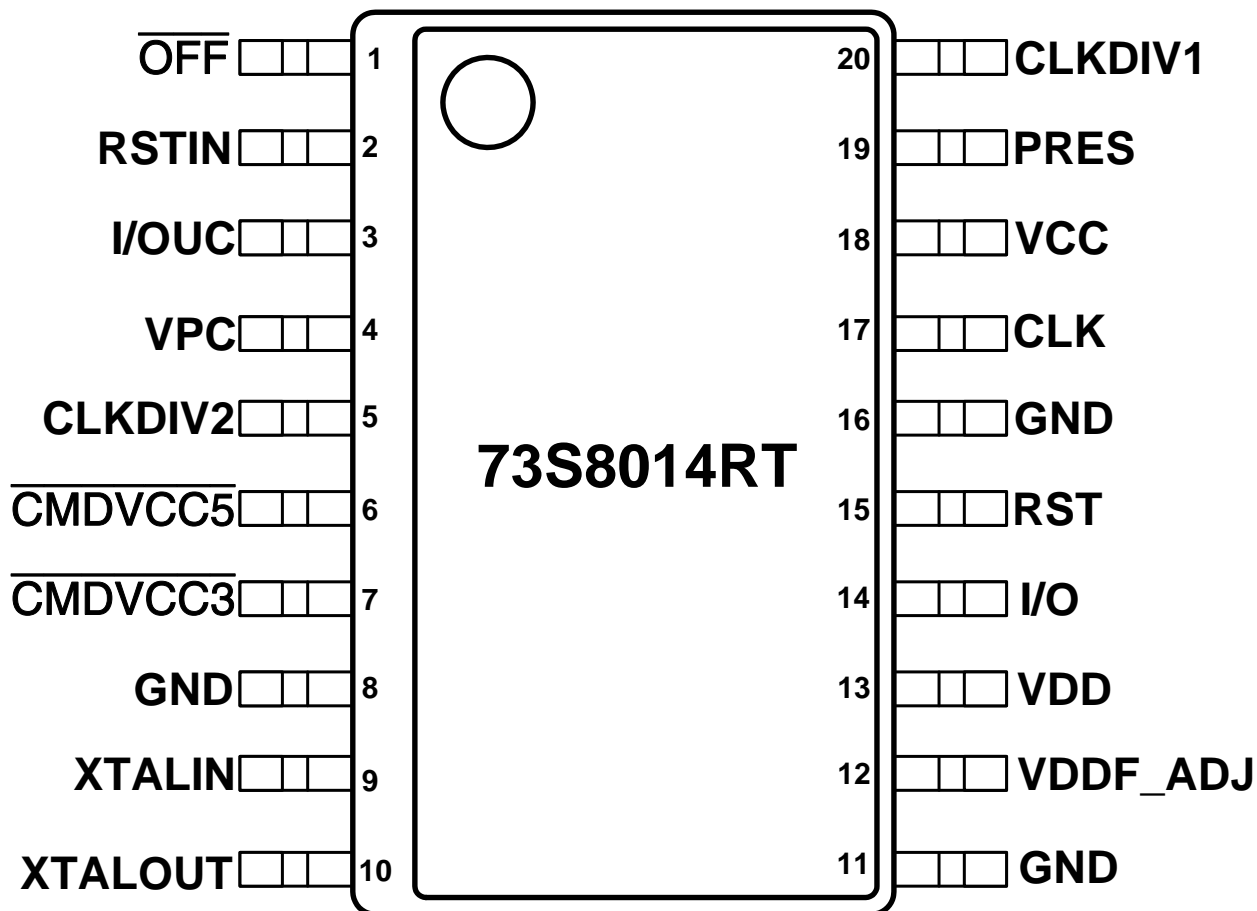

4 Appendix

This appendix includes the following tables and drawings of the PCB of the Evaluation Board:

- Electrical Schematic
- Bill of Materials
- Silk Screen Layer – Top side
- Silk Screen Layer – Bottom side
- Metal Layer – Top side
- Metal Layer – Middle 1, ground plane
- Metal Layer – Middle 2, supply plane
- Metal Layer – Bottom

Figure 4: TERIDIAN 73S8014R/RN/RT 20SO Demo Board: Electrical Schematic

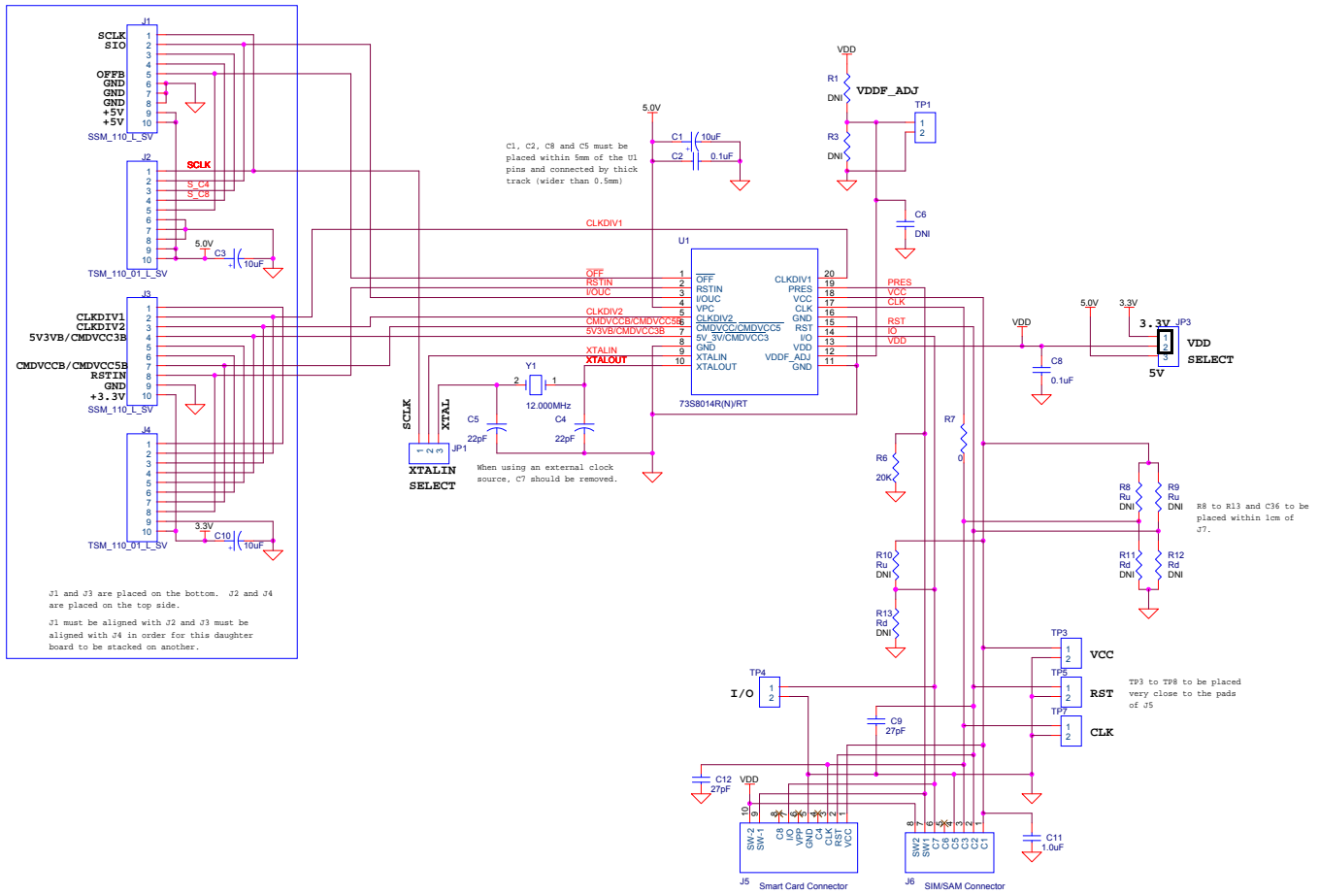

Table 6: TERIDIAN 73S8014R/RN/RT 20SO Demo Board: Bill of Material

Item	Qty	Reference	Part	PCB Footprint (see attached zip file)	Digikey Part Number	Part Number	Manufacturer
1	3	C1, C3, C10	CAP 10UF 6.3V CERAMIC X5R 0805	805	PCC2225CT-ND	ECJ-2FB0J106M	Panasonic
2	1	C11	CAP 1.0UF 6.3V CERAMIC X5R 0603	603	PCC1915CT-ND	ECJ-1VB0J105K	Panasonic
3	2	C2, C8	CAP .1UF 16V CERAMIC X7R 0603	603	PCC1762CT-ND	ECJ-1VB1C104K	Panasonic
4	2	C12, C9	CAP CERAMIC 27PF 50V 0603 SMD	603	PCC270ACVCT-ND	ECJ-1VC1H270J	Panasonic
5	2	C4, C5	CAP CERAMIC 22PF 50V 0603 SMD	603	PCC220ACVCT-ND	ECJ-1VC1H220J	Panasonic
6	1	R7	RES ZERO OHM 1/10W 5% 0603 SMD	603	P0.0GCT-ND	ERJ-3GEY0R00V	Panasonic
7	1	R6	RES 20K OHM 1/10W 5% 0603 SMD	603	P20KGCT-ND	ERJ-3GEYJ203V	Panasonic
8	1	J6	CONN SMART CARD SIM/SAM 6PIN SMD	ITT_CCM03-3013	401-1691-1-ND	CCM03-3754	ITT Industries
9	1	J5	CONN SMART CARD 8PIN SMD	CCM02-2504	401-1715-ND	CCM02-2504LFT	ITT Industries
10	5	TP1, TP3, TP4, TP5, TP7	HEADER 2	2pins, 2.54mm pich	S1011E-36-ND	PZC36SAAN	Sullins
11	2	JP1, JP3	HEADER 3	3pins, 2.54mm pich			
12	2	J1, J3	SSM_110_L_SV	SSM_110_L_SV	N/A	SSM_110_L_SV	Samtec
13	2	J2, J4	TSM_110_01_L_SV	TSM_110_01_L_SV	N/A	TSM_110_01_L_SV	Samtec
14	1	Y1	CRYSTAL 12.000 MHZ 20PF 49US	HC-49US	X190-ND	ECS-120-20-4DN	ENGYA
15	1	U1	73S8014R/RN/RT			73S8014R/RN/RT	Teridian Semiconductor

Note: The resistors and capacitors marked DNI are not populated on the board. They can be implemented to adjust the features of the smart card reader.

Figure 5: TERIDIAN 73S8014R/RN/RT 20SO Demo Board: Top View

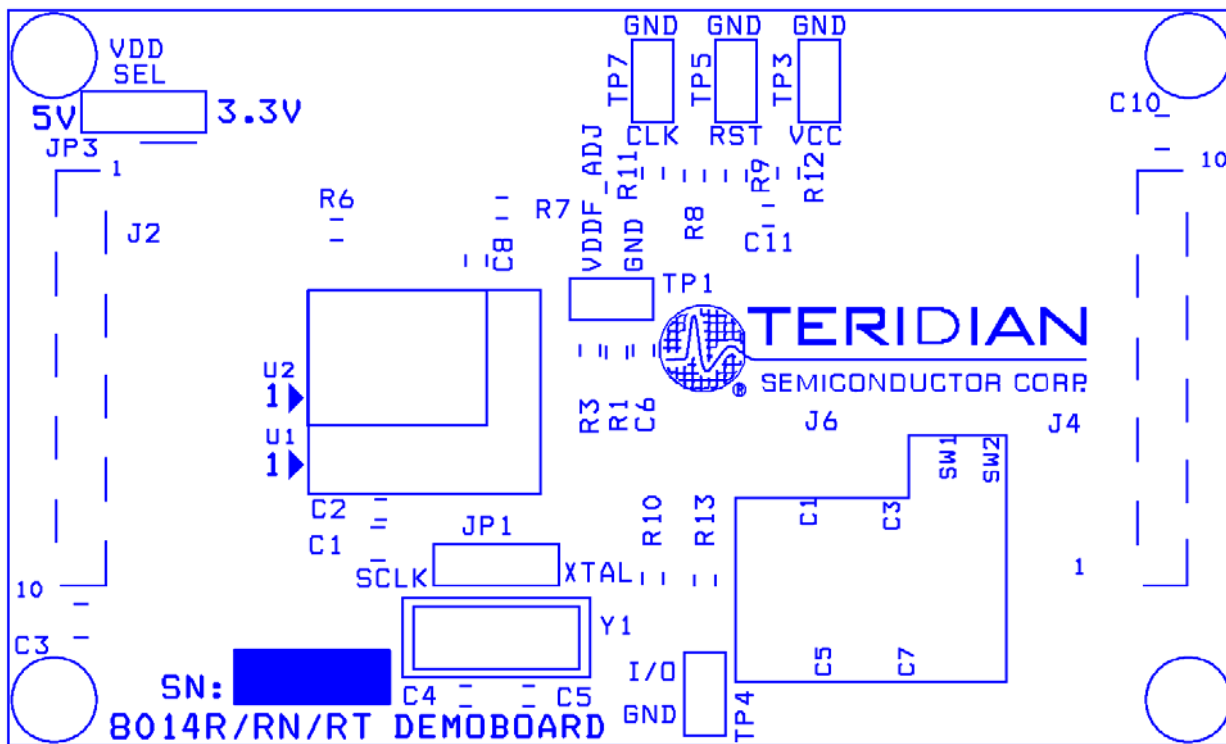

Figure 6: TERIDIAN 73S8014R/RN/RT 20SO Demo Board: Bottom View

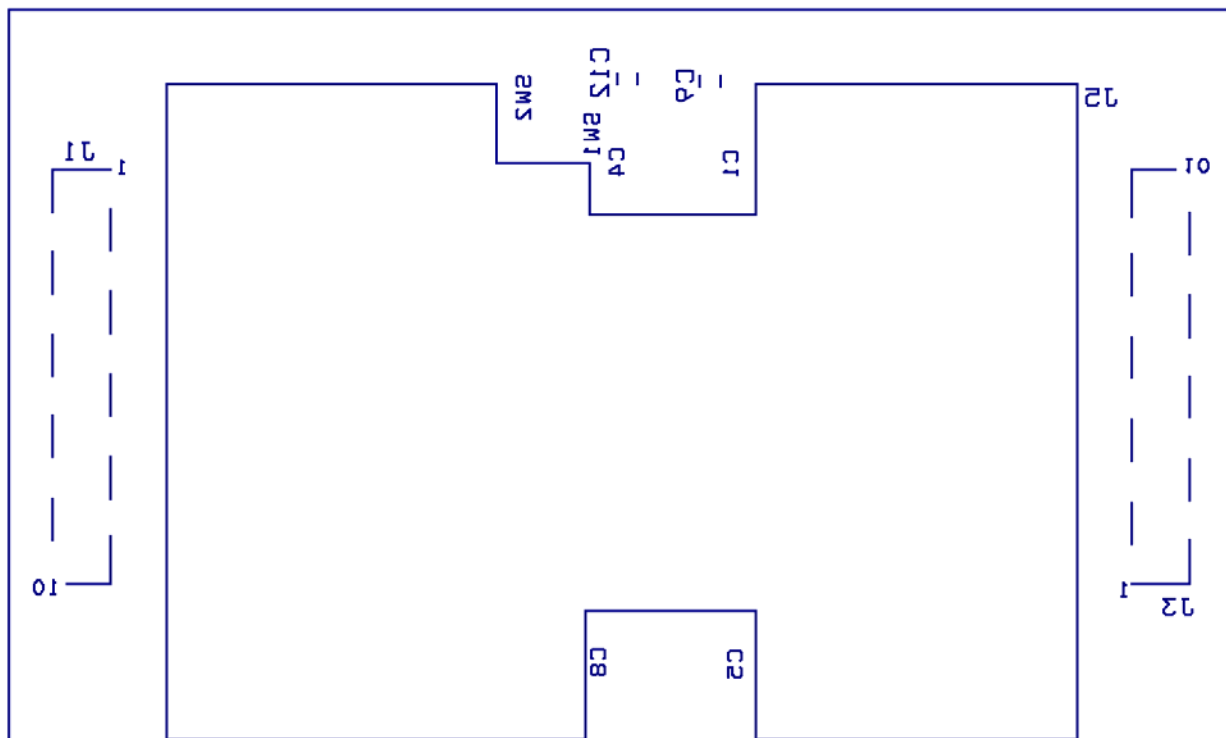

Figure 7: TERIDIAN 73S8014R/RN/RT 20SO Demo Board: Top Signal Layer

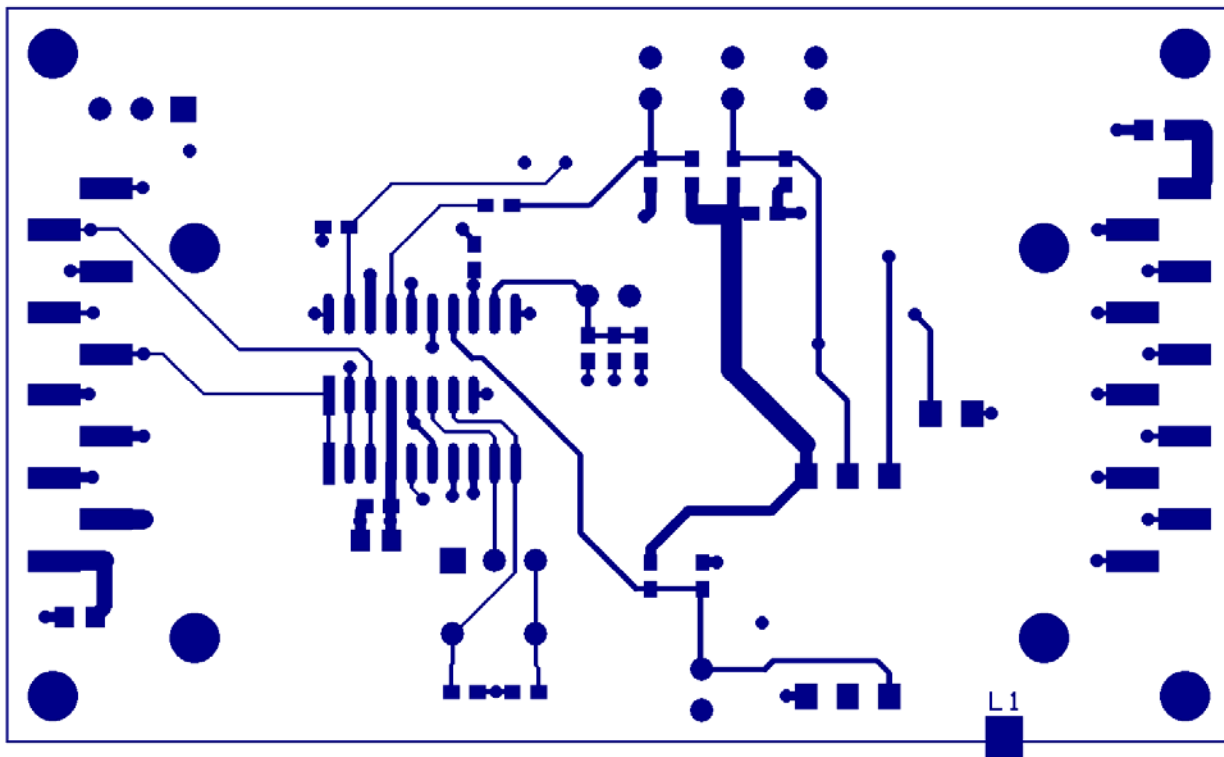

Figure 8: TERIDIAN 73S8014R/RN/RT 20SO Demo Board: Middle Layer 1, Ground Plane.

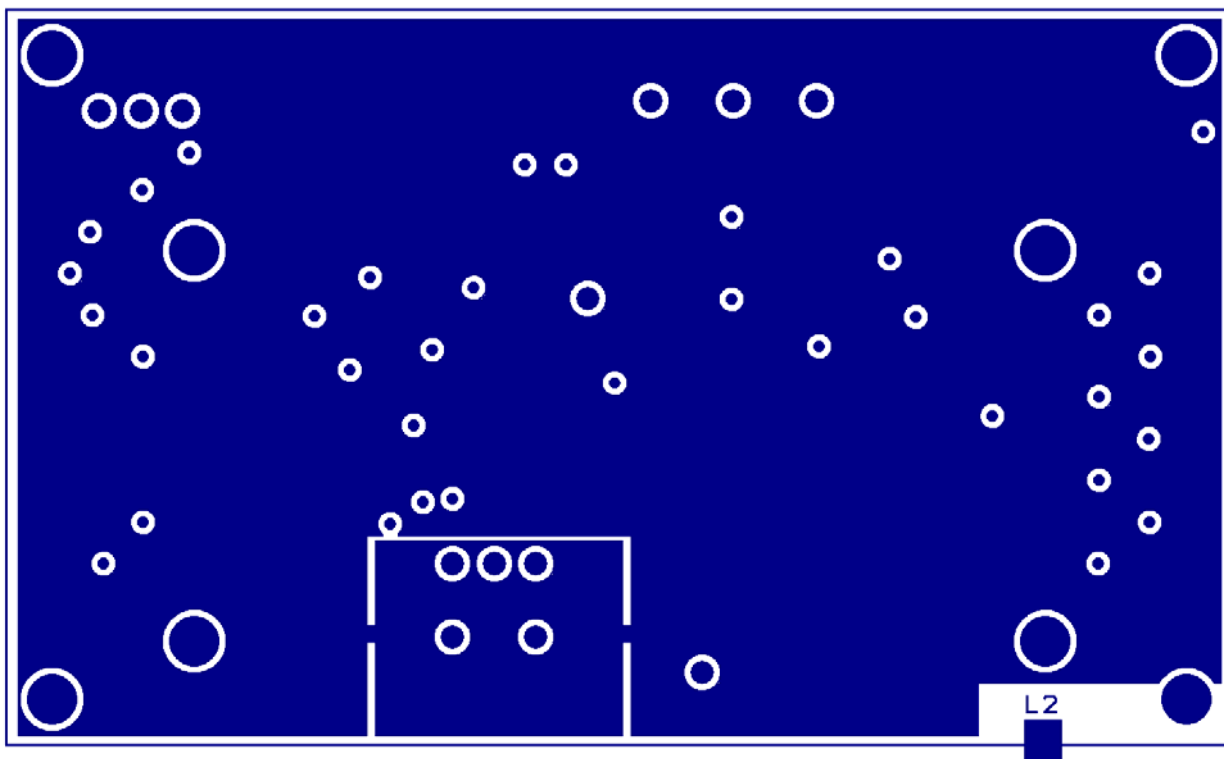

Figure 9: TERIDIAN 73S8014R/RN/RT 20SO Demo Board: Middle Layer 2, Supply Plane.

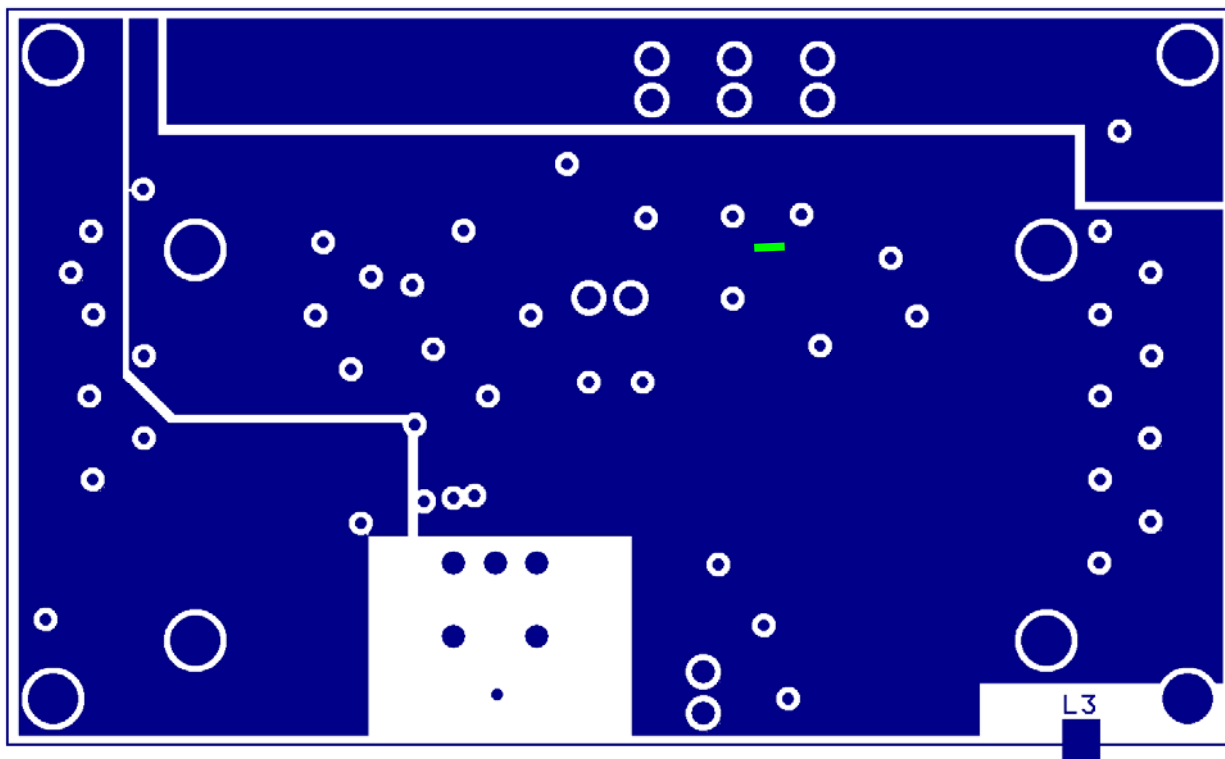
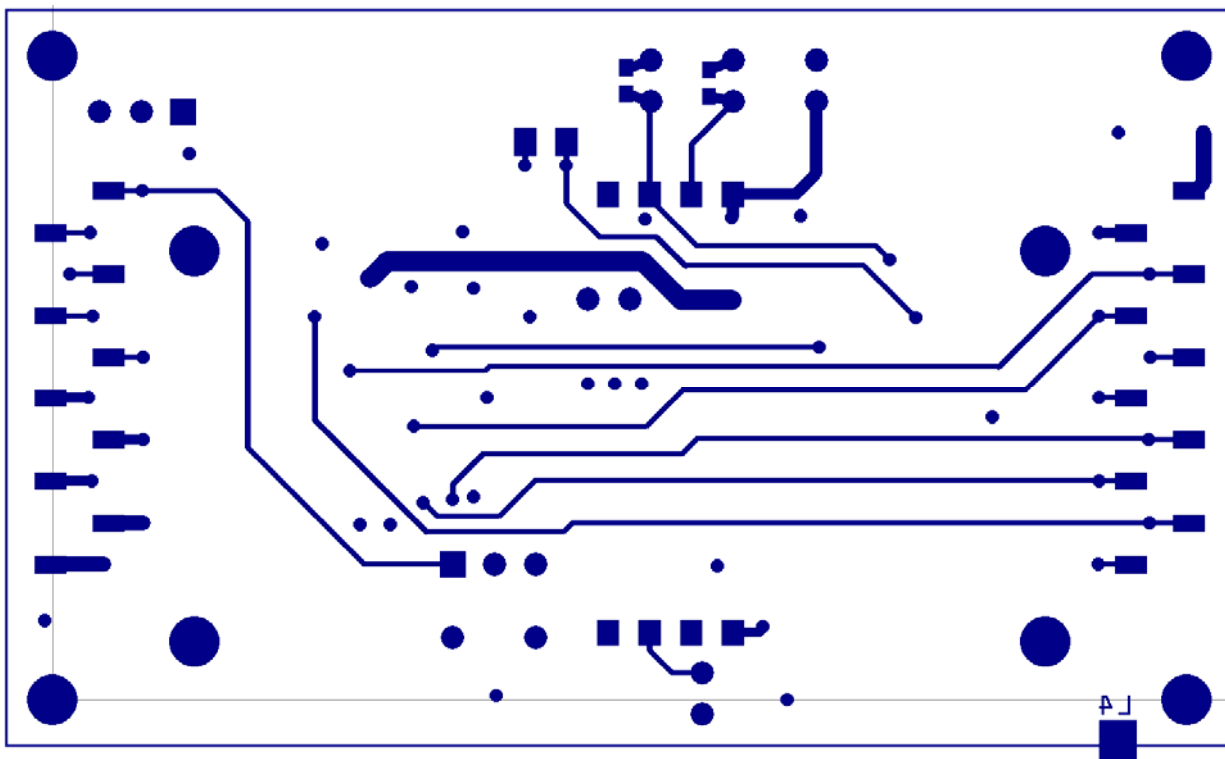

Figure 10: TERIDIAN 73S8014R/RN/RT 20SO Demo Board: Bottom Signal Layer



6 Contact Information

For more information about Teridian Semiconductor products or to check the availability of the 73S8014R/RN/RT, contact us at:

6440 Oak Canyon Road
Suite 100
Irvine, CA 92618-5201

Telephone: (714) 508-8800
FAX: (714) 508-8878
Email: scr.support@teridian.com

For a complete list of worldwide sales offices, go to <http://www.teridian.com>.

Revision History

Revision	Date	Description
1.0	7/3/2008	First publication.