



STEVAL-IHM031V1

3-phase low voltage inverter power board for FOC and scalar motor control based on the STS8DNH3LL MOSFET

Data brief

Features

- Bus voltage: 12 V - 24 V, up to 120 W
- 3-phase full bridge inverter topology
- Compact size with dual N-channel power MOSFETs
- Easily configurable for scalar and FOC motor control
- Motor current feedback via three shunt resistors
- Security functions:
 - overcurrent detection
 - bus voltage monitoring
 - temperature sensing
- RoHS compliant

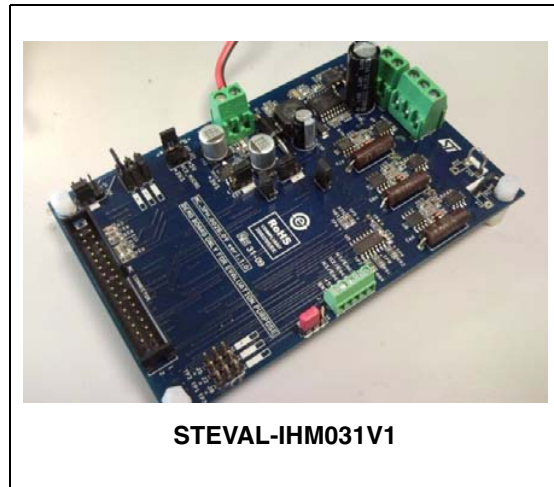

STEVAL-IHM031V1

Description

The STEVAL-IHM031V1 demonstration board is designed to drive a low voltage/low-to-medium current, 3-phase brushless, synchronous or asynchronous motor. It provides a compact solution along with efficient power dissipation thanks to dual in-package power MOSFETs.

This demonstration board integrates the following functional blocks: dedicated power supply for handling bus voltage in the range of 12 V to 24 V (up to 5 A), integrated gate driving, overcurrent protection, overvoltage and overtemperature sensing, three-shunt current sensing for FOC control, single-shunt sensing for trapezoidal control, BEMF sensing and amplification (for both GE and STMicroelectronics methods) and motor control connector.

The on-board MC connector allows the demonstration board to be interfaced with any STMicroelectronics MCU control board with a dedicated connector in order to control several types of 3-phase motors (asynchronous, PMSM brushless DC and brushless AC).

1 Schematic diagrams

Figure 1. BEMF and sensor inputs

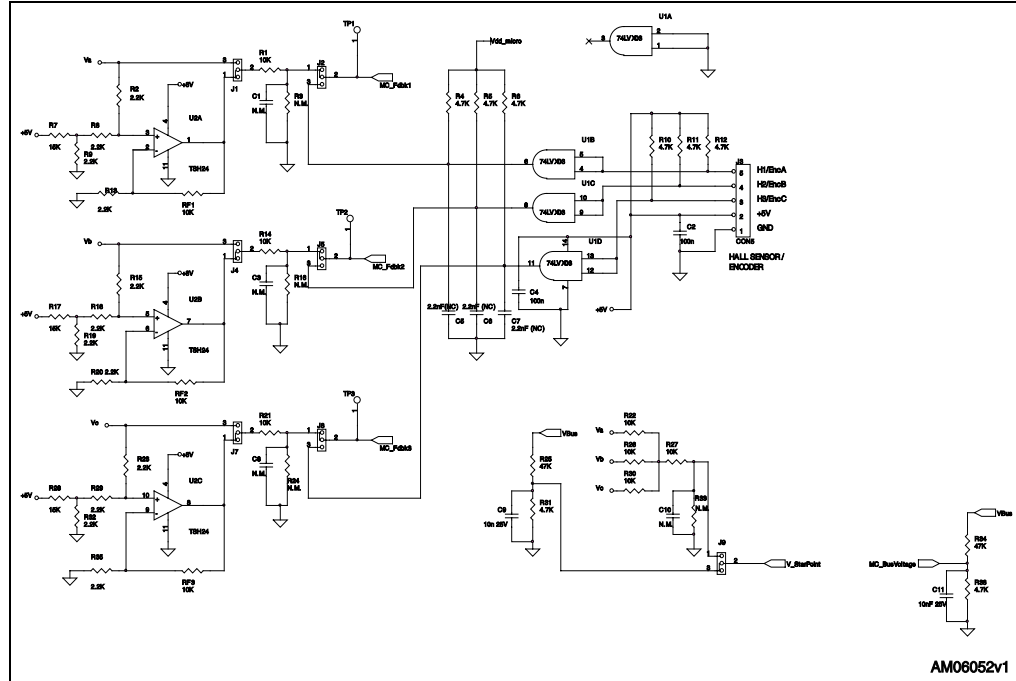

Figure 3. Drivers and power MOSFETs

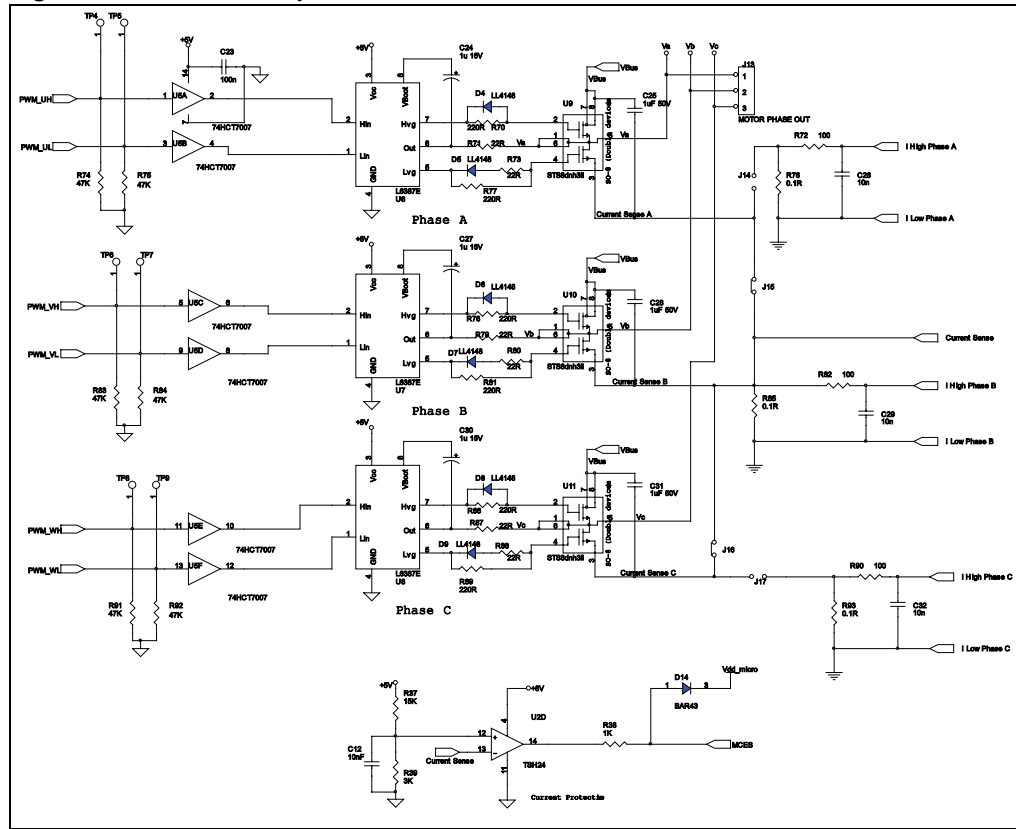
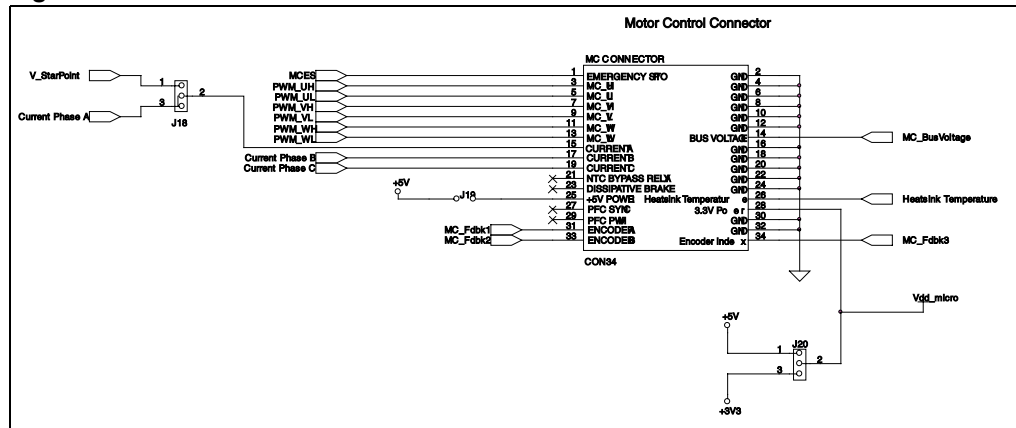

Figure 4. Motor control connector



2 Revision history

Table 1. Document revision history

Date	Revision	Changes
13-Jan-2010	1	Initial release.

Please Read Carefully:

Information in this document is provided solely in connection with ST products. STMicroelectronics NV and its subsidiaries ("ST") reserve the right to make changes, corrections, modifications or improvements, to this document, and the products and services described herein at any time, without notice.

All ST products are sold pursuant to ST's terms and conditions of sale.

Purchasers are solely responsible for the choice, selection and use of the ST products and services described herein, and ST assumes no liability whatsoever relating to the choice, selection or use of the ST products and services described herein.

No license, express or implied, by estoppel or otherwise, to any intellectual property rights is granted under this document. If any part of this document refers to any third party products or services it shall not be deemed a license grant by ST for the use of such third party products or services, or any intellectual property contained therein or considered as a warranty covering the use in any manner whatsoever of such third party products or services or any intellectual property contained therein.

UNLESS OTHERWISE SET FORTH IN ST'S TERMS AND CONDITIONS OF SALE ST DISCLAIMS ANY EXPRESS OR IMPLIED WARRANTY WITH RESPECT TO THE USE AND/OR SALE OF ST PRODUCTS INCLUDING WITHOUT LIMITATION IMPLIED WARRANTIES OF MERCHANTABILITY, FITNESS FOR A PARTICULAR PURPOSE (AND THEIR EQUIVALENTS UNDER THE LAWS OF ANY JURISDICTION), OR INFRINGEMENT OF ANY PATENT, COPYRIGHT OR OTHER INTELLECTUAL PROPERTY RIGHT.

UNLESS EXPRESSLY APPROVED IN WRITING BY AN AUTHORIZED ST REPRESENTATIVE, ST PRODUCTS ARE NOT RECOMMENDED, AUTHORIZED OR WARRANTED FOR USE IN MILITARY, AIR CRAFT, SPACE, LIFE SAVING, OR LIFE SUSTAINING APPLICATIONS, NOR IN PRODUCTS OR SYSTEMS WHERE FAILURE OR MALFUNCTION MAY RESULT IN PERSONAL INJURY, DEATH, OR SEVERE PROPERTY OR ENVIRONMENTAL DAMAGE. ST PRODUCTS WHICH ARE NOT SPECIFIED AS "AUTOMOTIVE GRADE" MAY ONLY BE USED IN AUTOMOTIVE APPLICATIONS AT USER'S OWN RISK.

Resale of ST products with provisions different from the statements and/or technical features set forth in this document shall immediately void any warranty granted by ST for the ST product or service described herein and shall not create or extend in any manner whatsoever, any liability of ST.

ST and the ST logo are trademarks or registered trademarks of ST in various countries.

Information in this document supersedes and replaces all information previously supplied.

The ST logo is a registered trademark of STMicroelectronics. All other names are the property of their respective owners.

© 2010 STMicroelectronics - All rights reserved

STMicroelectronics group of companies

Australia - Belgium - Brazil - Canada - China - Czech Republic - Finland - France - Germany - Hong Kong - India - Israel - Italy - Japan - Malaysia - Malta - Morocco - Philippines - Singapore - Spain - Sweden - Switzerland - United Kingdom - United States of America

www.st.com