



30W Power over Ethernet Adapter High Power, High Temperature Single Port Injector



Features

- Fully Compliant IEEE802.3af
- Diagnostic LEDs
- Non-Vented Case
- Wide Temperature Range: -20 to +55°C
- UNH IOL Tested
- Full Protection OCP, OVP
- Gigabit Compatible

Applications

- IP Telephones
- Wireless Network Access Points
- Blue Tooth Access Points
- Security Cameras
- IP Print Servers

Safety Approvals

- cUL/UL
- CE
- Korea K
- C-Tick
- CCC
- SAA
- S-Jet
- IRAM

Mechanical Characteristics

- Length: 166mm (6.48in)
- Width: 80mm (3.15in)
- Height: 44mm (1.73in)
- Weight: 0.3Kg (0.51lb)

Output Specifications

Model	DC Output Voltage	Load		Regulation	
		Min.	Max.	Line	Load
POE30U-560(G)-HT	56V	0A	0.55A	54-57V DC under all conditions	

Phihong is not responsible for any error, and reserves the right to make changes without notice. Please visit our website at www.phihong.com for the most up-to-date specifications and contact information.

INPUT:

AC Input Voltage Range
85 to 264VAC

AC Input Voltage Rating
100 to 240VAC

AC Input Frequency
47-63Hz

AC Input Current
15A (RMS) maximum for 115VAC
20A (RMS) maximum for 230VAC

Leakage Current
0.25mA maximum for 264VAC 50Hz for input to PE
3.5mA maximum for 264VAC 50Hz for input to output

AC Inrush Current
15A (RMS) maximum for 115VAC
20A (RMS) maximum for 230VAC

OUTPUT:
Total Output Power
30W at 56V DC

DC Offset
No data degradation with DC imbalance 18mA per min.

Efficiency
75% (typical) at maximum load, and 120VAC 60Hz

Hold-up Time
16mS min. and 120VAC at maximum load

Transient O/P Voltage Protection
60V maximum zener clamp

ENVIRONMENTAL:

Temperature
Operation -20 to +55°C
Non-operation -40 to +85°C
Humidity 10 to 90%

EMC

FCC Part 15 Class B
EN55022 Class B

Isolation Test

Primary to Secondary: 4242VDC for 1 minute 10mA
Primary to F.G.: 2121VDC for 1 minute
Output to F.G.: 2121VDC

Immunity

ESD: EN61000-4-2. Level 3
RS: EN61000-4-3. Level 2
EFT: EN61000-4-4. Level 2
Surge: EN61000-4-5. Level 3
CS: EN61000-4-6. Level 2
Voltage Dips EN61000-4-11
Harmonic: EN61000-3-2

Insulation Resistance

Primary to Secondary: >10M OHM 500VDC
Primary to Field Ground: >10M OHM 500VDC

IEEE 802.3at Interoperability

UNH Interoperability report available upon request

FEATURE:

Over Voltage/Current, Short Circuit Protection
The output can be shorted permanently without damage

Indicators

Green LED 1: Power detected "ON"
Green LED 2: Valid "PoE Plus" load detected and connected
Green LED 3: Valid IEEE802.3af load detected and connected

Input Connector

IEC320 inlet 3 pin

Output Connection

+pins 3, 6
-pins 1, 2

Dimension Diagram Unit: mm

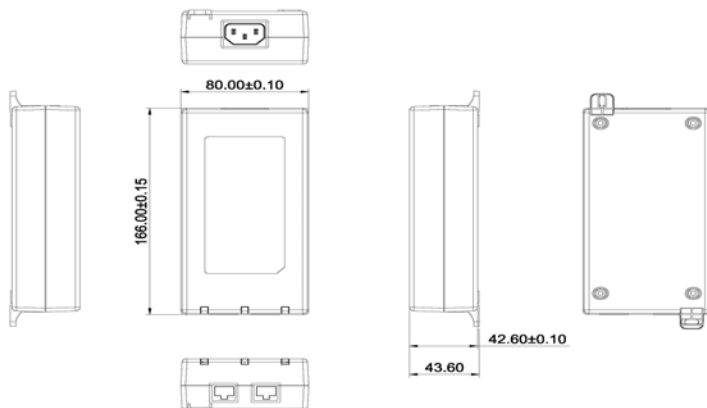



POE30U-560(G) –HT-R Schematic Block Diagram

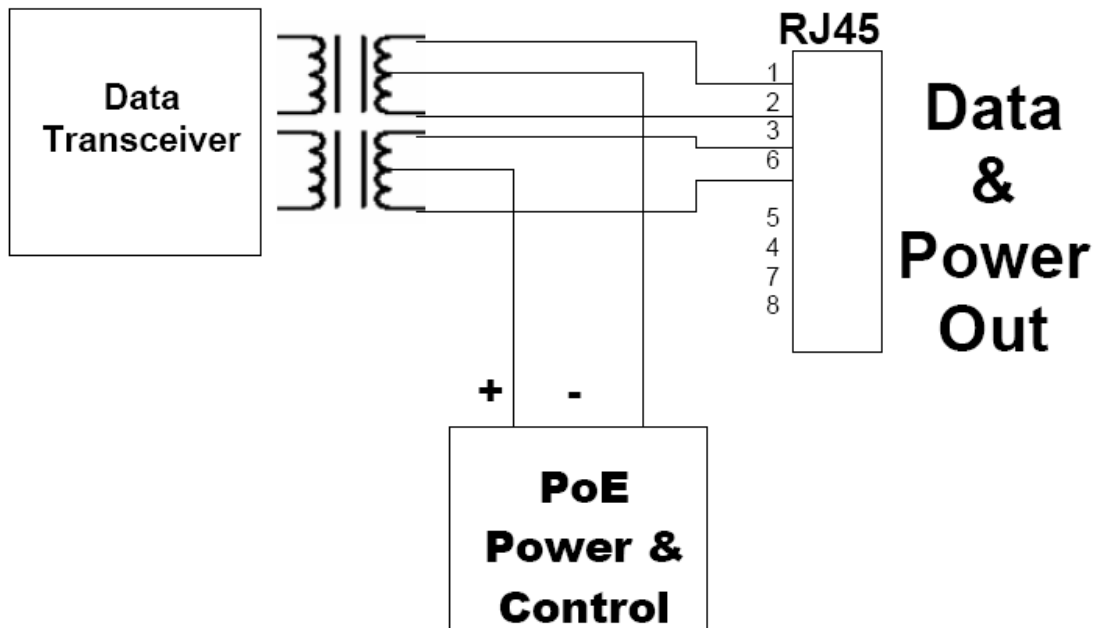

Description of LED Functions for Gigabit Power Injector

Power-up Sequence:

Upon power-up, all 3 LEDs will light for 2 seconds, as part of the self-test for the internal microprocessor software. After the 2 seconds, the "ON" LED will illuminate green. The DC output voltage is now available for powering a compliant load (to the 802.3at PoE standards).

Detection Sequence:

Once a compliant load is attached to the output RJ45 connector, the green "CONNECT" LED will illuminate.

Should the load be non-compliant then the LEDs will blink a code signifying the cause for non-detection.

Detection Failure Codes:

1. Incorrect resistive signature – The green "CONNECT" and red "FAULT" LEDs will blink 3 times.
2. Incorrect capacitive signature – The green "ON" LED will blink 3 times.
3. Incorrect Voffset – The green "CONNECT" and green "ON" LEDs will blink 3 times.
4. Unstable current measurement – The green "ON" LED will blink 3 times
5. Low voltage sensed during detection (overload) – The red "FAULT" LED will blink 3 times

After the LEDs blink 3 times the Power Injector will continue to try to detect a valid load. Until the correct load is applied, the LEDs will continue to blink. If there is an open circuit connected to the output RJ45 then the LEDs will not blink but the Power Injector will continue to try to detect a valid load.

Fault Sequence:

Should a fault occur such as an overload or short circuit then the red "FAULT" LED will illuminate. The red "FAULT" LED will illuminate for 2 seconds and then go off as the power supply tries to re-detect a valid load. If there is a problem detecting the load, the LED will indicate the possible fault as per the codes in the section above.