

REV.	DESCRIPTION	DATE	APPROVED
B	Engineering Update w/o Changes	03/09/04	M. C.
C	Material Code Correction	02/08/07	M. C.

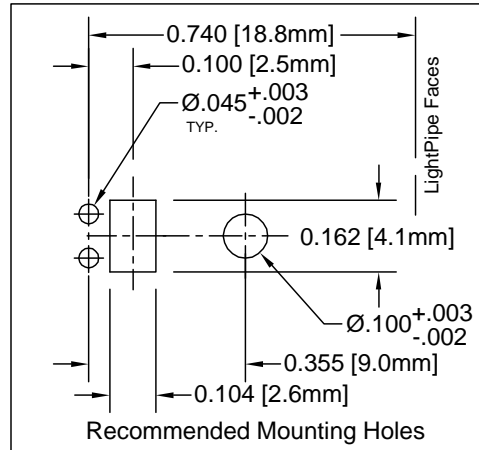
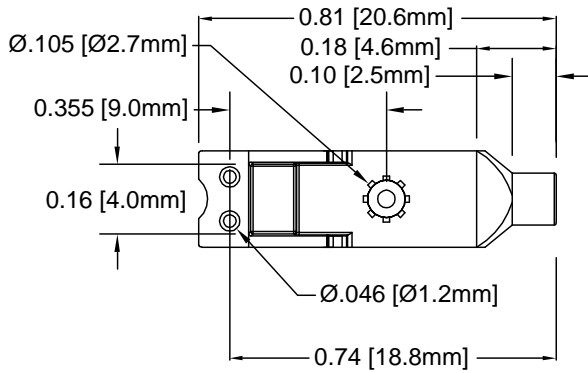
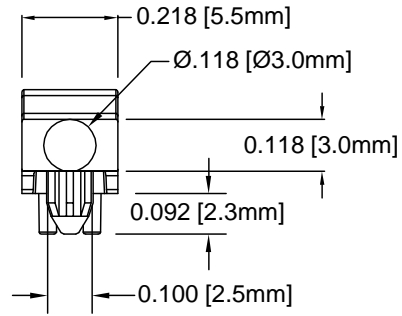
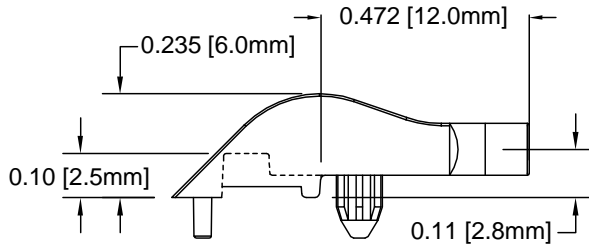

STANDARD TOLERANCE (UNLESS OTHERWISE SPECIFIED)	
DECIMALS	ANGULAR
.X ± .1	X° ± 1°
.XX ± .01	
.XXX ± .005	

BIVAR[®]
 4 THOMAS, IRVINE, CA. 92618
 TEL: (949) 951-8808 FAX: (949) 951-3974

2. MATERIAL: POLYCARBONATE, 94V-0, CLEAR. BIVAR MATERIAL CODE 47-CR.
 SAM YANG CORPORATION POLYCARBONATE 3025N2 CLEAR.

1. GENERAL SPECIFICATIONS: BIVAR MOLDED COMPONENT SPECIFICATION BV00-E101.

DESIGNED: Shane Irving	DATE: 11/23/98	TITLE: LIGHT PIPE, 90° SURFACE MOUNT	REVISION: C
CHECKED: D. Green	DATE: 12/04/02	PART NO: SLP-1-3	CAGE CODE : 32559 SHEET # 1 OF 1
CAD GENERATED DOCUMENT. DO NOT MEASURE DRAWING.			