

REV.	DESCRIPTION	DATE	APPROVED
A	Engineering Update w/o Changes	03/09/04	M. C.
B	TYPO Correction, Dim. 0.775" was 0.740".	05/11/05	M. C.
C	Updated Material Code.	02/12/07	M. C.

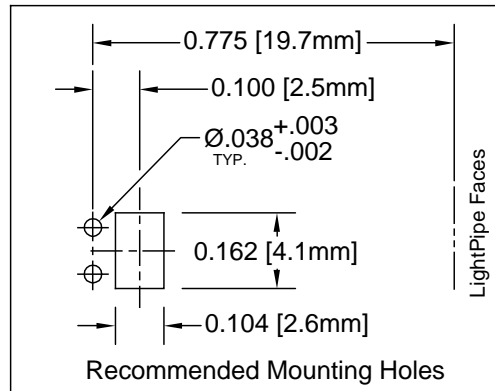
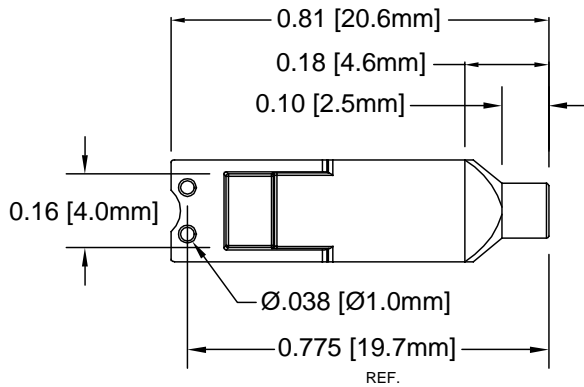
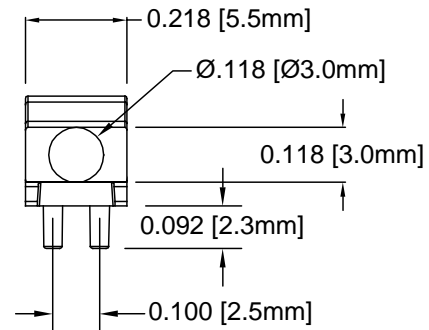
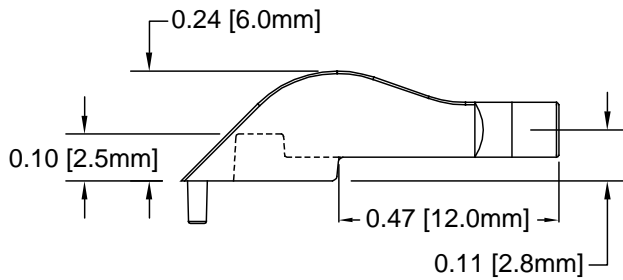

2. MATERIAL: POLYCARBONATE, 94V-0, CLEAR. BIVAR MATERIAL CODE 47-CR.
SAM YANG CORPORATION POLYCARBONATE 3025N2 CLEAR.
1. GENERAL SPECIFICATIONS: BIVAR MOLDED COMPONENT SPECIFICATION BV00-E101.

STANDARD TOLERANCE (UNLESS OTHERWISE SPECIFIED)		BIVAR®	
DECIMALS	ANGULAR	4 THOMAS, IRVINE, CA. 92618 TEL: (949) 951-8808 FAX: (949) 951-3974	
.X ±.1	X° ± 1°	TITLE: LIGHT PIPE, 90° SURFACE MOUNT	
.XX ±.01		PART NO: SLP-1	REVISION: C
.XXX ±.005		CAGE CODE: 32559	SHEET # 1 OF 1
DESIGNED: Shane Irving	DATE: 11/23/98	CAD GENERATED DOCUMENT. DO NOT MEASURE DRAWING.	
CHECKED: R. Dienst	DATE: 08/14/00		