

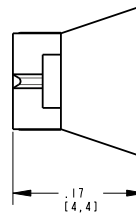

- NOTES:
1. UNLESS OTHERWISE SPECIFIED, ALL SURFACES MUST HAVE FINISH OF SP1 A1 TO A2.
 2. UNLESS OTHERWISE SPECIFIED, SINK MARKS & KNOCKOUT MARKS NOT TO EXCEED .003 RECESSED.
 3. FLASH NOT TO EXCEED .005.
 4. NO BUBBLES IN LIGHTPATH GREATER THAN .003.
 5. MAKE FROM 515-1033F WITH PERMISSIBLE IRREGULAR CUT-OFF VESTIGE ALLOWABLE.
 6. UNLESS OTHERWISE SPECIFIED, .003 ROUNDS & FILLETS PERMISSABLE.
 7. UNLESS OTHERWISE SPECIFIED, 2 DEGREE DRAFT PERMISSIBLE.
 8. MATERIAL TO BE CLEAR, TRANSMISSIVE POLYCARBONATE UL 94V-0 OR EQUIVALENT, AS SPECIFIED BY DIALIGHT ENGINEERING DEPT.
 9. * DENOTES CRITICAL DIMENSION OR SPECIFICATION.
 10. DIALIGHT PART NUMBER 515-1033-801F.
 12. RECOMMEND PANEL HOLE DIAMETER .141±.002. PANEL THICKNESS .039 FOR FLUSH MOUNTING.

REV	ECN NO	REVISIONS	DRN	CKD	APP	DATE
A		NEW RELEASE	TWC			

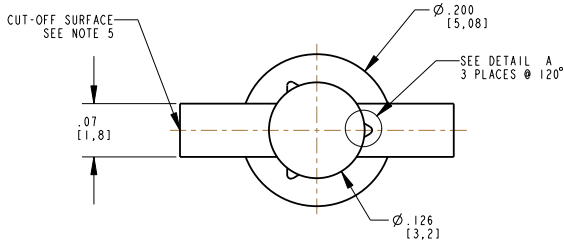
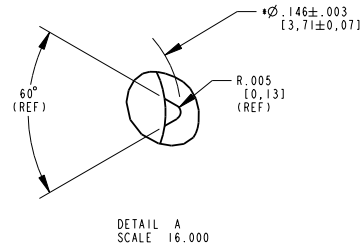
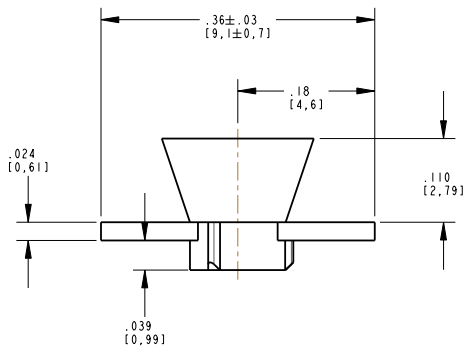

THIS DRAWING AND THE CONTENTS HEREIN ARE CONFIDENTIAL AND THE SOLE PROPERTY OF DIALIGHT. REPRODUCTION OF THIS DRAWING OR CONSTRUCTION OF ANY PARTS WITHIN THIS DRAWING ARE FORBIDDEN WITHOUT THE WRITTEN CONSENT OF DIALIGHT.		
SCALE: 7.000 ALL DIM'S IN: INCHES (MM)	DRAWING NUMBER C-17355	REV A
TOLERANCES: UNLESS OTHERWISE SPECIFIED FRACTIONS: ±1/64 DECIMALS (.XX): ±.01 DECIMALS (.XXX): ±.005 DECIMALS (.XXXX): ±.0005 ANGLES: ±1°	TITLE 1 ELEMENT LIGHTPIPE RoHS COMPLIANT	
FINISH: -	MATERIAL POLYCARBONATE	
FSCM 83330	 1501 ROUTE 34 SOUTH FARMINGDALE, NJ 07727	
SHEET 1 OF 1 FAMILY TABLE:		