

REV.	DESCRIPTION	DATE	APPROVED
B	Engineering Update w/o Changes	03/09/04	M. C.
C	Removed SLP3-150-XXX-X Spec.	06/04/08	M. C.

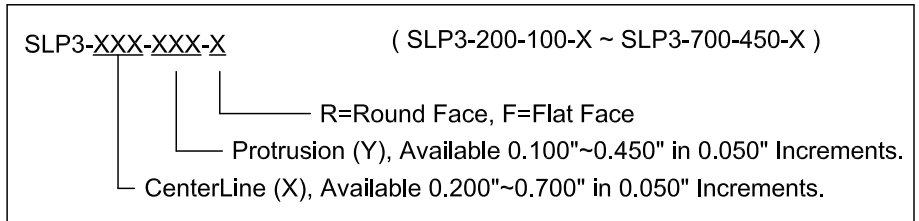
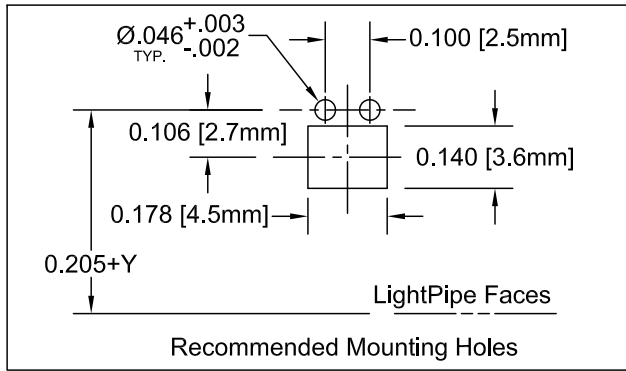
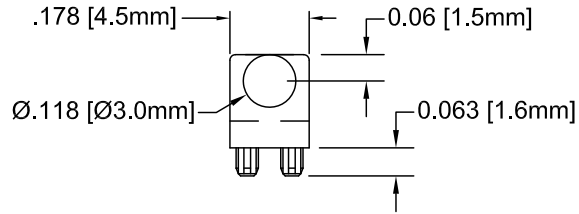
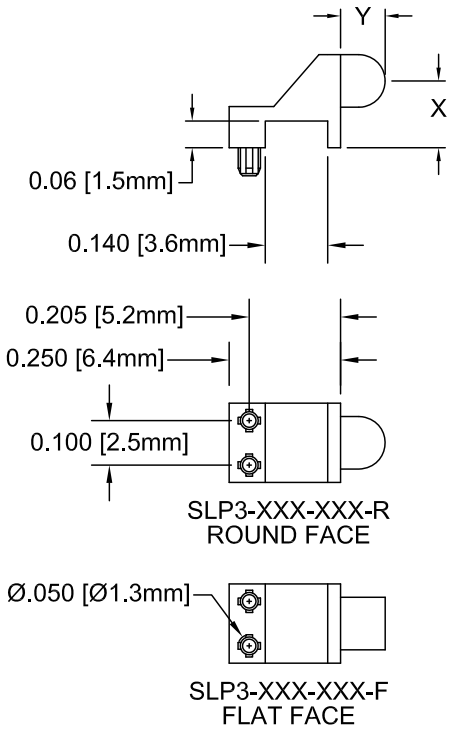

2. MATERIAL: POLYCARBONATE, 94V-HB, CLEAR. BIVAR MATERIAL CODE 49-CR.
ENTECH HYLEX POLYCARBONATE P1017L CLEAR.
1. GENERAL SPECIFICATIONS: BIVAR MOLDED COMPONENT SPECIFICATION BV00-E101.

STANDARD TOLERANCE (UNLESS OTHERWISE SPECIFIED)		 4 THOMAS, IRVINE, CA, 92618 TEL: (949) 951-8808 FAX: (949) 951-3974			
DECIMALS	ANGULAR				
.X ± .1	X° ± 1°	TITLE: LIGHT PIPE 90° VARIABLE CENTERLINE			
.XX ± .01					
.XXX ± .005		DESIGNED: Michael Chen	DATE: 04/14/03	PART NO: SLP-3-XXX-XXX-X	REVISION: C
CHECKED: D. Green		DATE: 04/14/03		CAGE CODE : 32559	SHEET # 1 OF 1
CAD GENERATED DOCUMENT. DO NOT MEASURE DRAWING.					