

REV	ECN NO	REVISIONS	DRW	CKD	APP	DATE
A		NEW RELEASE	KLJ			

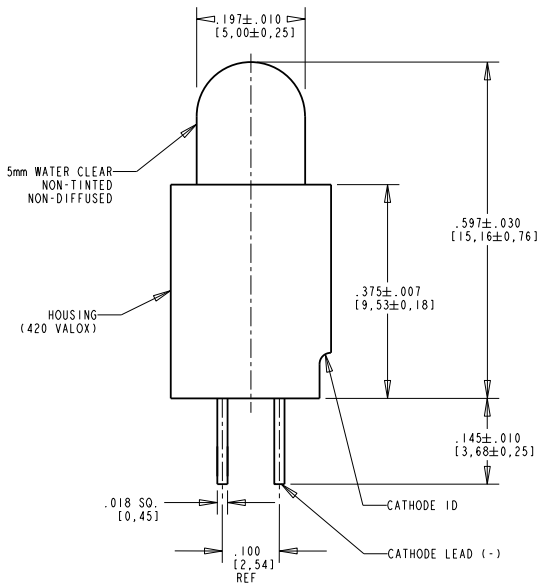

LED CHARACTERISTICS	COLOR	MIN.	TYP.	MAX.	UNITS	TEST CONDITIONS
LUMINOUS INTENSITY	RED	80.0	125.0	—	mcd	I _r = 20 mA
	GREEN	112.0	265.0	418.0		
	YELLOW	96.0	140.0	184.0		
FORWARD VOLTAGE	RED	—	2.2	3.0	V	I _r = 20 mA
	GREEN	1.5	2.2	3.0		
REVERSE VOLTAGE	RED	—	5.0	—	V	I _r = 100 mA
	GREEN	—	5.0	—		
PEAK WAVELENGTH	RED	—	635	—	nm	
	GREEN	—	565	—		
DOMINANT WAVELENGTH	RED	—	—	—	nm	
	GREEN	562	569	576		
VIEWING ANGLE (2 θ 1/2)	RED	—	—	—	DEG	
	GREEN	578	585	593		
VIEWING ANGLE (2 θ 1/2)	ALL		24			

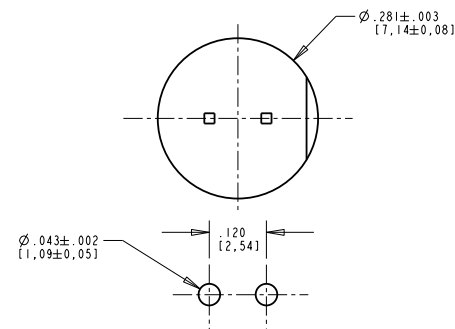

NOTES:

- REQUIRES EXTERNAL RESISTOR.
- THIS ASSEMBLY CONTAINS ELECTROSTATIC DISCHARGE SENSITIVE DEVICES (ESDS). MAINTAIN ALL PRECAUTIONARY MEASURES DURING ASSEMBLY, HANDLING AND STORAGE IN ACCORDANCE WITH IPC-A-610.
- DIALIGHT PART NUMBERS: 561-5501-803F RED
561-5601-805F GREEN
561-5701-802F YELLOW

RoHS Compliant 561-5X01-80XF

Part Numbers with the "F" suffix ending are RoHS Compliant. The bag packaging is marked with "RoHS Compliant" label or equivalent markings. Parts can be wave soldered, dip soldered or hand soldered using typical lead-free soldering process with max 260°C temp. for 5 sec.

ABSOLUTE MAXIMUM RATINGS	COLOR	UNITS
AVERAGE FORWARD CURRENT	RED	30
	GREEN	25
	YELLOW	20
PEAK FORWARD CURRENT	RED	90
	GREEN	60
TRANSIENT FORWARD CURRENT (10 ms PULSE)	ALL	500
LEAD SOLDERING TEMPERATURE FOR 5 SEC.	ALL	260
OPERATING TEMPERATURE	RED	-55 TO +100
	GREEN	-20 TO +100
	YELLOW	-55 TO +100
STORAGE TEMPERATURE	ALL	-55 TO +100



ATTENTION:
OBSERVE PRECAUTIONS FOR
HANDLING ELECTROSTATIC
SENSITIVE DEVICES

THIS DRAWING AND THE CONTENTS HEREIN ARE CONFIDENTIAL AND THE SOLE PROPERTY OF DIALIGHT. REPRODUCTION OF THIS DRAWING OR CONSTRUCTION OF ANY PARTS WITHIN THIS DRAWING ARE FORBIDDEN WITHOUT THE WRITTEN CONSENT OF DIALIGHT.		
SCALE: DRAWING SCALE ALL DIM'S IN: INCHES (MM)	DRAWING NUMBER C-17567	REV A
TOLERANCES: UNLESS OTHERWISE SPECIFIED FRACTIONS (.XX): ±.01 DECIMALS (.XXX): ±.005 DECIMALS (.XXXX): ±.0005 ANGLES: ±1°	TITLE 5mm VERTICAL CBI RoHS COMPLIANT	MATERIAL
FINISH:	1501 ROUTE 34 SOUTH FARMINGDALE, NJ 07727	
FSCM 83330	SHEET 1 OF 1 FAMILY TABLE:	