

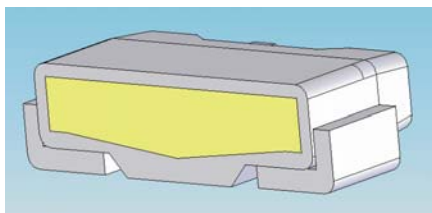

SURFACE MOUNT WHITE LED SIDE VIEW 2.8 X 1.2 X 0.8mm

FEATURES

- SIDE VIEW WHITE
- LED (2.8 x 1.2 x 0.8mm)
- WHITE SMT PACKAGE
- LEAD FRAME PACKAGE WITH INDIVIDUAL 2-PINS
- InGaN WITH YELLOW PHOSPHOR
- WIDE VIEW ANGLE (X: 120°/Y: 120°)
- IR REFLOW SOLDERING
- ESD PROTECTION

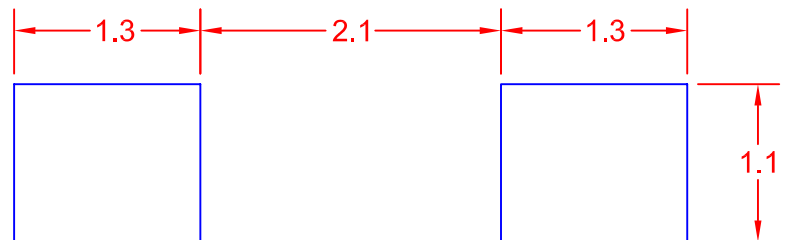
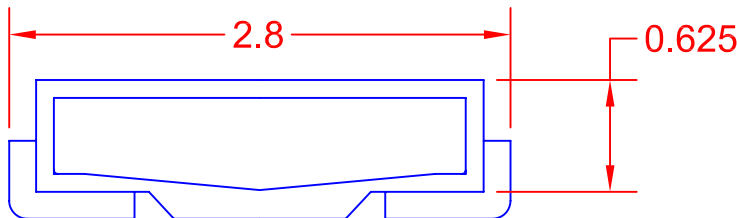
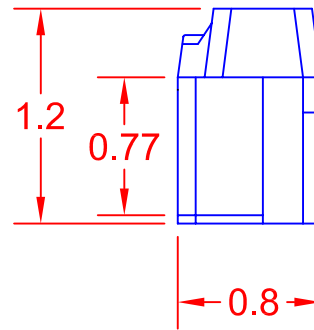
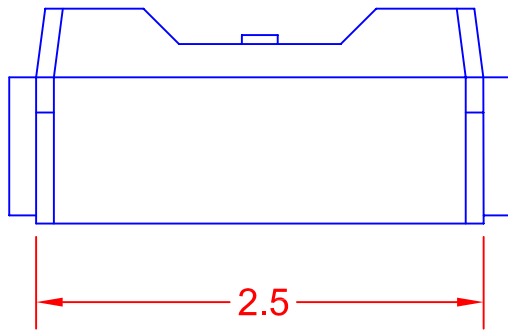

JKL PART NO.: ZSM-S2808-W

RECOMMENDED SOLDERING PAD LAYOUT





SURFACE MOUNT WHITE LED SIDE VIEW 2.8 X 1.2 X 0.8mm

SPECIFICATIONS

ABSOLUTE MAXIMUM RATINGS (TA = 25°C)
(LED die)

ITEM	SYMBOL	ABSOLUTE MAXIMUM RATING	UNIT
Forward Current	I_F	30	mA
Pulse Forward Current*	I_{FP}	100	mA
Reverse Voltage	V_R	5	V
Power Dissipation	P_D	120	mW
Operating Temperature	T_{opr}	-30 ~ +85	°C
Storage Temperature	T_{stg}	-40 ~ +100	°C
Soldering Temperature	T_{sld}	Reflow Soldering: 260° C for 10 secs Hand Soldering: 350° C for 3 secs	

(Zener diode)

ITEM	SYMBOL	CONDITION	MIN	MAX	UNIT
Reverse Leakage Current	I_R	$V_R = 5V$	---	0.5	uA
Zener Voltage	V_Z	$I_Z = 5mA$	5.8	6.8	V
Forward Voltage	V_F	$I_F = 20mA$	---	1.2	V

* I_{FP} Conditions: Pulse Width $\leq 10msec$, and duty $\leq 1/10$

ELECTRICAL & OPTICAL OPERATING CHARACTERISTICS (TA = 25°C)

ITEM	SYMBOL	CONDITION	MIN	MAX	UNIT
Forward Voltage	V_F	$I_F = 20mA$	2.8	3.6	Volt
Luminous Intensity	L_V	$I_F = 20mA$	1000	1400	mcd
Color Coordinates	x, y	$I_F = 20mA$.267	.304	x
			.260	.290	y
Viewing Angle	---	$I_F = 20mA$	120° x	120° y	Degrees



SURFACE MOUNT WHITE LED SIDE VIEW 2.8 X 1.2 X 0.8mm

		K1			
x		0.2890	0.2835	0.2788	0.2843
y		0.2900	0.2800	0.2800	0.2900
		K3			
x		0.2780	0.2725	0.2673	0.2730
y		0.2700	0.2600	0.2600	0.2700
		W2			
x		0.2886	0.2831	0.2780	0.2835
y		0.2800	0.2700	0.2700	0.2800
		X1			
x		0.2993	0.2938	0.2886	0.2941
y		0.2900	0.2800	0.2800	0.2900
		X3			
x		0.2883	0.2829	0.2778	0.2831
y		0.2700	0.2600	0.2600	0.2700
		Y2			
x		0.2987	0.2932	0.2883	0.2938
y		0.2800	0.2700	0.2700	0.2800

		K2			
x		0.2835	0.2780	0.2730	0.2788
y		0.2800	0.2700	0.2700	0.2800
		W1			
x		0.2941	0.2886	0.2835	0.2890
y		0.2900	0.2800	0.2800	0.2900
		W3			
x		0.2831	0.2778	0.2725	0.2780
y		0.2700	0.2600	0.2600	0.2700
		X2			
x		0.2938	0.2883	0.2831	0.2886
y		0.2800	0.2700	0.2700	0.2800
		Y1			
x		0.3042	0.2987	0.2938	0.2993
y		0.2900	0.2800	0.2800	0.2900
		Y3			
x		0.2932	0.2879	0.2829	0.2883
y		0.2700	0.2600	0.2600	0.2700

BIN RANGE OF CHROMATICITY COORDINATES

*If color binning is required, only one color group is allowed for each chip within a reel.

Chromaticity coordinate groups are measured with an accuracy of ± 0.01 .

*Color coordinate is derived from the CIE 1931 chromaticity.

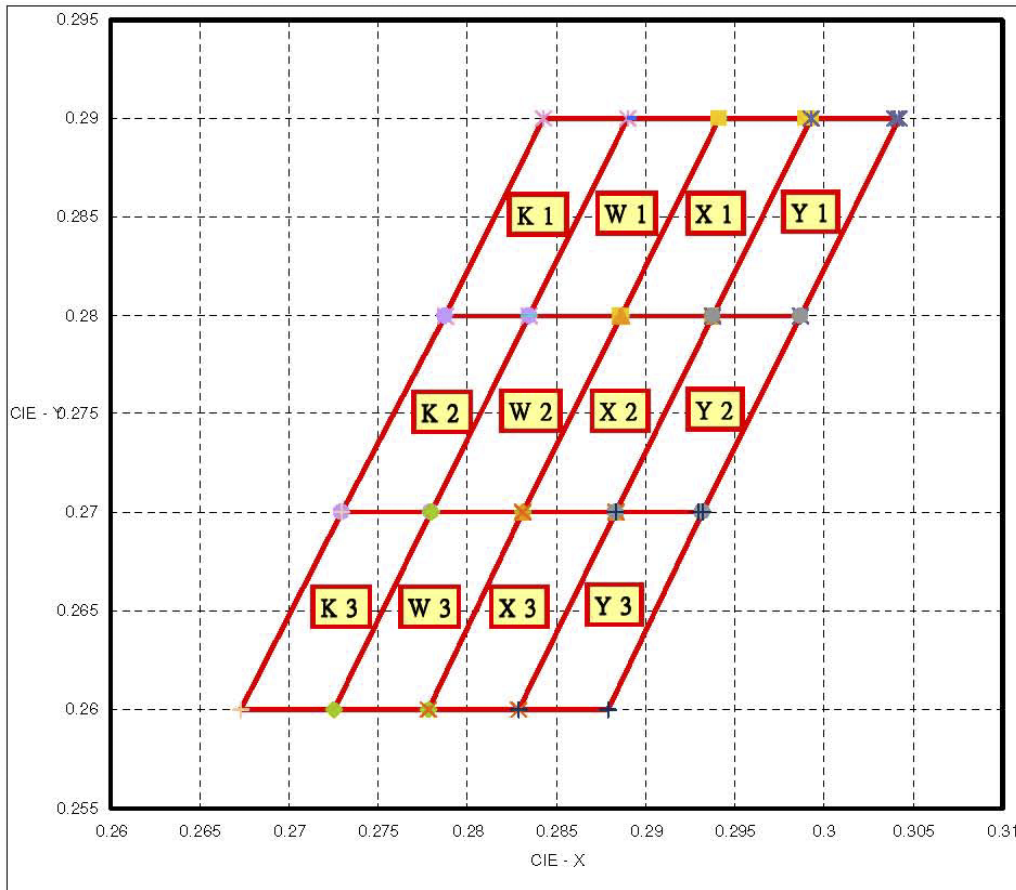



SURFACE MOUNT WHITE LED SIDE VIEW 2.8 X 1.2 X 0.8mm

TYPICAL ELECTRO-OPTICAL CHARACTERISTICS CURVES

Forward voltage vs. Forward current

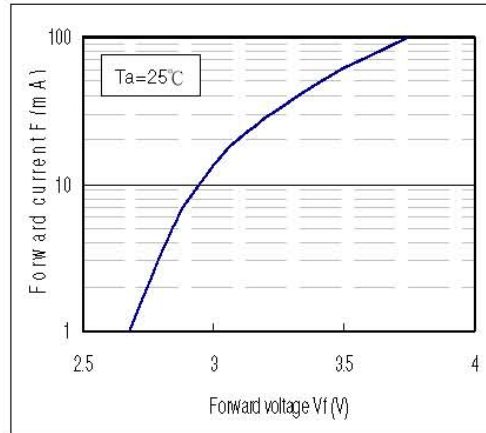

Forward current vs. Relative luminosity

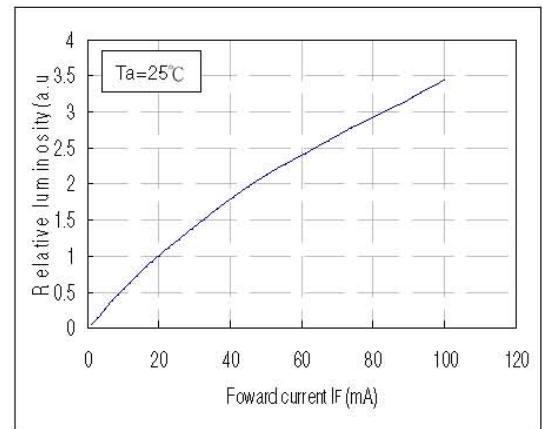

Duty ratio vs. Allowable forward current

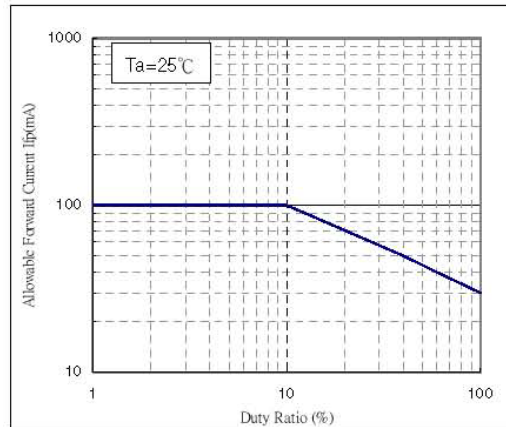

Ambient temperature vs. Forward voltage

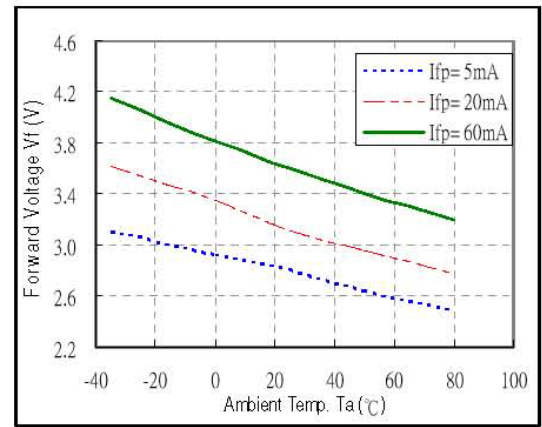

Ambient temperature vs. Relative luminosity

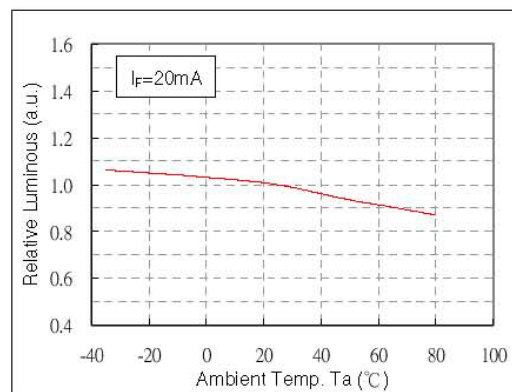

Ambient temperature vs. Allowable forward current

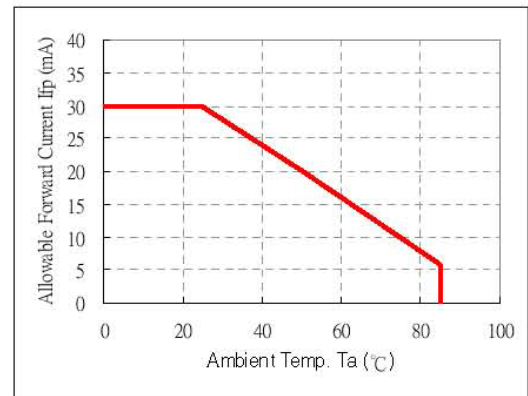



SURFACE MOUNT WHITE LED SIDE VIEW 2.8 X 1.2 X 0.8mm

TYPICAL ELECTRO-OPTICAL CHARACTERISTICS CURVES (Continued)

Forward current vs. Chromaticity diagram

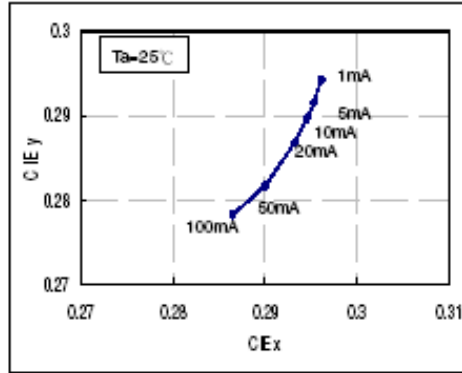

Spectrum

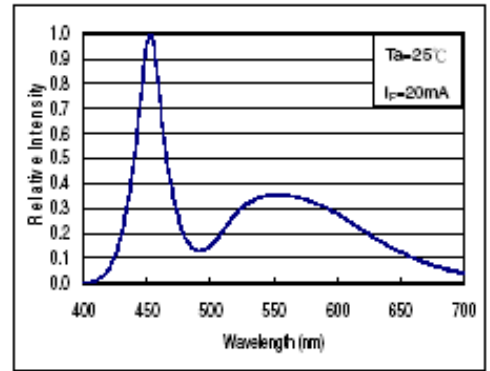

Ambient temperature vs. Chromaticity diagram

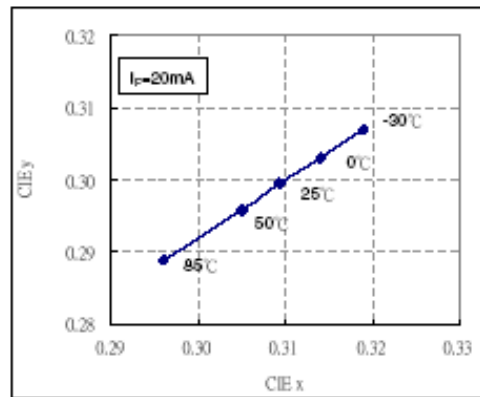

Radiation pattern

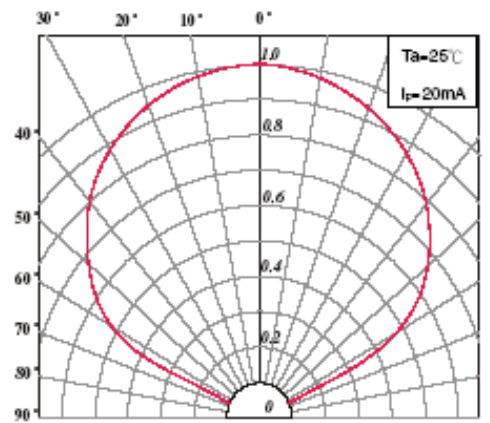

PACKAGING: 3000 pcs/REEL

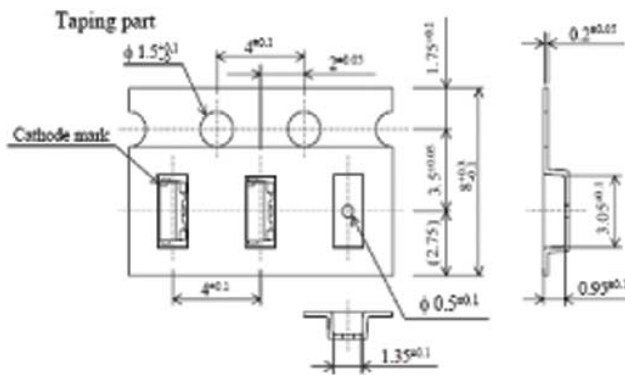

NOTES:

1. STORE IN ORIGINAL MOISTURE PROOF PACKAGING.
2. PACKAGING SHOULD BE STORED AT 30°C OR LESS AND AT 60% RH OR LESS.
3. LED SHOULD BE SOLDERED WITHIN 168 HOURS AFTER OPENING.
4. LED'S ARE STATIC SENSITIVE DEVICES. DO NOT HANDLE WITHOUT APPROPRIATE STATIC PROTECTION.
5. CLEAN ONLY WITH ISOPROPYL ALCOHOL. DO NOT USE ULTRASONIC CLEANING.
6. **CAUTION:** DO NOT LOOK DIRECTLY INTO LIT LED. INJURY TO EYES CAN OCCUR.