

UNCONTROLLED DOCUMENT

PART NUMBER
LCT-H800480M70W1T

REV.

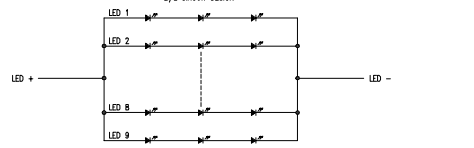
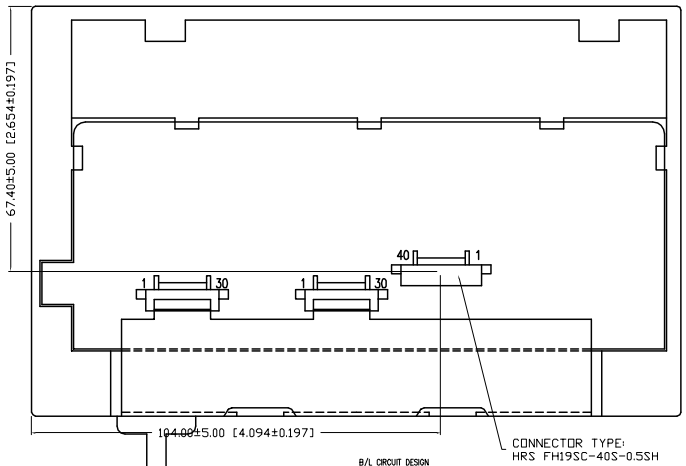
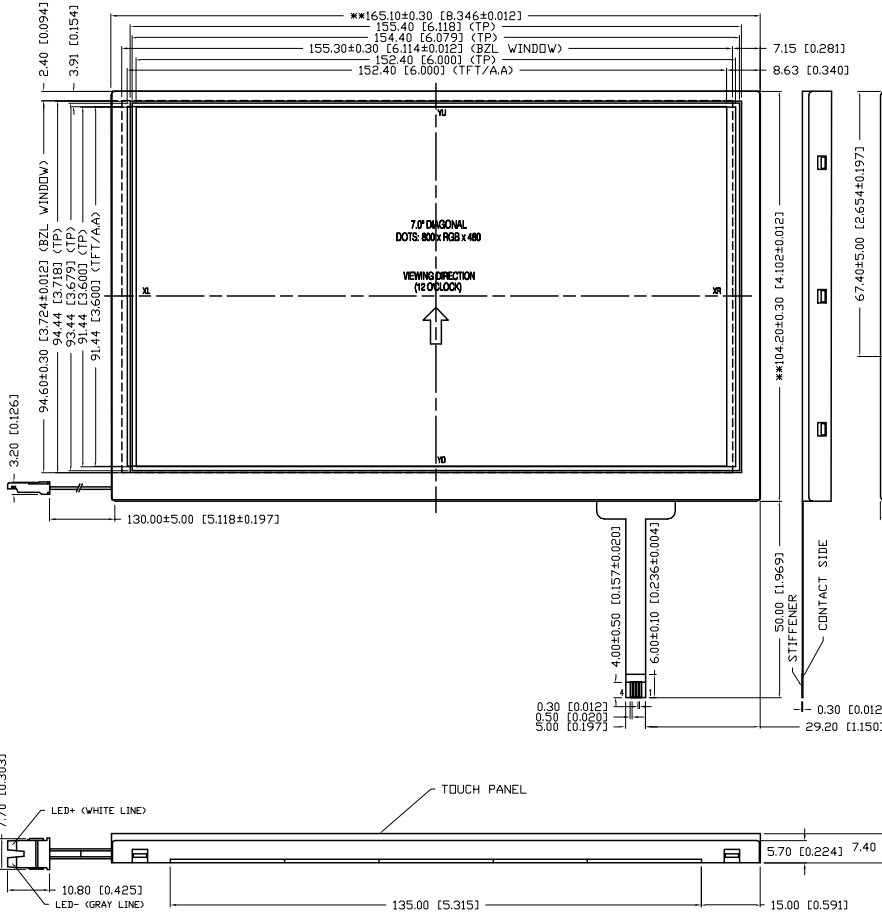

NOTES:
 1. SPECIAL DIMENSION PPK/CPK DATA NEEDED > 1.67
 2. CONTROL DIMENSION
 3. ALL UNMARKED $\frac{1}{2}$ OR *** DIMENSIONS ARE REFERENCE DIMENSIONS AND NO MEASUREMENT NEEDED.
 4. GREENFROGS PRODUCT: YES
 5. THE SPECIFICATIONS MAY CHANGE AT ANY TIME WITHOUT NOTICE DUE TO NEW MATERIALS OR PRODUCT IMPROVEMENT.

NOTE:
 THE LED CONDITION IS DEFINED FOR EACH LED MODULE (3x9=27 LED)
 FORWARD VOLTAGE: VF=0.6V TYP;
 FORWARD CURRENT: IF=180mA;
 BACKLIGHT COLOR: WHITE



UNCONTROLLED DOCUMENT

*UNLESS OTHERWISE SPECIFIED TOLERANCES PER DECIMAL PRECISION ARE: X=±1 (±0.039), X.X=±0.5 (±0.020), X.XX=±0.25 (±0.010), X.XXX=±0.127 (±0.005), LEAD SIZE=±0.05 (±0.002), LEAD LENGTH=±0.75 (±0.030), MIN.=+DECIMAL PRECISION MAX.=+0.00 -DECIMAL PRECISION

REV.	PART NUMBER
	LCT-H800480M70W1T

CONFIDENTIAL INFORMATION
 THE INFORMATION CONTAINED IN THIS DOCUMENT IS THE PROPERTY OF LUMEX INC. EXCEPT AS SPECIFICALLY AUTHORIZED IN WRITING BY LUMEX INC., THE HOLDER OF THIS DOCUMENT SHALL KEEP ALL INFORMATION CONTAINED HEREIN CONFIDENTIAL AND SHALL PROTECT SAME IN WHOLE OR IN PART FROM DISCLOSURE AND DISSEMINATION TO ALL THIRD PARTIES.



290 E. HELEN ROAD
 PALATINE, IL 60067-6976
 PHONE: +1.847.359.2790
 US WEB: www.lumex.com
 TW WEB: www.lumex.com.tw

7.0" ACTIVE MATRIX FULL COLOR TFT PANEL
 12:00 VIEW, LED BACKLIGHT, W/ TOUCH PANEL,
 -20°C TO +70°C OPERATING TEMP.

RELIABILITY NOTE
 OUR MANY YEARS OF EXPERIENCE DATA ACCUMULATION INDICATE THAT SOLDER HEAT IS A MAJOR CAUSE OF EARLY AND FUTURE FAILURE. PLEASE PAY ATTENTION TO YOUR SOLDERING PROCESS.

DRAWN BY:
JN

CHECKED BY:

APPROVED BY:

DATE: 06.08.09
 PAGE: 1 OF 11
 SCALE: N/A

UNCONTROLLED DOCUMENT

PART NUMBER	REV.
LCT-H800480M70W1T	

BACKLIGHT SPECIFICATIONS

ITEM	SYMBOL	STANDARD VALUE			UNIT	REMARK
		MIN	TYP.	MAX		
LED VOLTAGE	VL	-	9.6	12	V	NOTE 2
LED CURRENT	IL	-	180	-	mA	NOTE 2
LED LIFE TIME	-	20,000	-	-	Hr	NOTE 1

NOTE (1): THE "LED LIFE TIME" IS DEFINED AS THE MODULE BRIGHTNESS DECREASE TO 50% ORIGINAL BRIGHTNESS THAT THE AMBIENT TEMPERATURE IS 25°C AND IL=20mA.
 NOTE (2): THE LED DRIVING CONDITION IS DEFINED FOR EACH LED MODULE. (3 LED SERIAL)

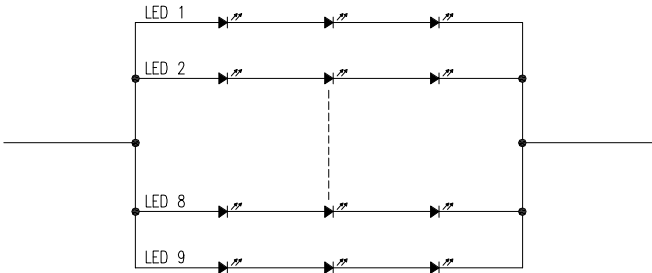

ITEM	CONTENTS	UNIT
DISPLAY TECHNOLOGY	7.0" (DIAGONAL) TFT NORMALLY WHITE TRANSMISSIVE LCD	-
MODULE OUTER DIMENSION	165.1(H) x 104.2 (V) x 6.0(D)(MAX)	mm
PIXEL SIZE	120(H) x 360(V)	μm
ACTIVE DISPLAY AREA	152.40(H) x 91.44(V)	mm
NUMBER OF DOTS	800FG8480	DOTS
VIEWING DIRECTION	12	CLOCK
PIXEL ARRANGEMENT	RGB STRIPE	-
PIXEL PITCH	0.0635 (H) x 0.1905 (V)	mm
BACKLIGHT	LED BACKLIGHT/WHITE	-
PIXEL DRIVING ELEMENT	a-Si TFT	-
MPU INTERFACE	TTL DIGITAL	-
DRIVE IC	H88232-A02(SOCURE) X3 + H88643-A00(GATE) X1	-
T-CON IC	NT38703-5	-
NUMBER OF COLORS	262K COLORS	-
OPERATING TEMPERATURE	-20~70	°C
STORAGE TEMPERATURE	-30~80	°C
WEIGHT	180	g

TOUCH PANEL SPECIFICATIONS

ITEM	DESCRIPTION	STANDARD VALUE			CONDITIONS
		MIN	TYP.	MAX	
TOTAL TRANSMITTANCE	-	80%	-	-	JIS K7105
OPERATING FORCE	PEN INPUT	80g	-	100g	DIAMETER 3.0mm, SR 0.8mm
	FINGER INPUT	80g	-	100g	DIAMETER 12.0mm, SR 12.5mm
LOOP RESISTANCE	X AXIS	200	-	900	-
	Y AXIS	400	-	900	-
INSULATION RESISTANCE	-	20	-	-	At DC 25V
KNOCKING LIFE	-	1000000	-	-	250g, 2HZ SHAPE OF PEN END R 0.8mm
CHATTERING	-	-	-	10ms	-



*UNLESS OTHERWISE SPECIFIED TOLERANCES PER DECIMAL PRECISION ARE: X=±1 (±0.039), X.X=±0.5 (±0.020), X.XX=±0.25 (±0.010), X.XXX=±0.127 (±0.005). LEAD SIZE=±0.05 (±0.002), LEAD LENGTH=±0.75 (±0.030). MIN±DECIMAL PRECISION MAX.= +0.00 -DECIMAL PRECISION -0.00

UNCONTROLLED DOCUMENT

REV.	PART NUMBER LCT-H800480M70W1T	<p>CONFIDENTIAL INFORMATION</p> <p>THE INFORMATION CONTAINED IN THIS DOCUMENT IS THE PROPERTY OF LUMEX INC. EXCEPT AS SPECIFICALLY AUTHORIZED IN WRITING BY LUMEX INC., THE HOLDER OF THIS DOCUMENT SHALL KEEP ALL INFORMATION CONTAINED HEREIN CONFIDENTIAL AND SHALL PROTECT SAME IN WHOLE OR IN PART FROM DISCLOSURE AND DISSEMINATION TO ALL THIRD PARTIES.</p> <p>RELIABILITY NOTE</p> <p>OUR MANY YEARS OF EXPERIENCE DATA ACCUMULATION INDICATE THAT SOLDER HEAT IS A MAJOR CAUSE OF EARLY AND FUTURE FAILURE. PLEASE PAY ATTENTION TO YOUR SOLDERING PROCESS.</p>	<p>290 E. HELEN ROAD PALATINE, IL 60067-6976 PHONE: +1.847.359.2790 US WEB: www.lumex.com TW WEB: www.lumex.com.tw</p>
	7.0" ACTIVE MATRIX FULL COLOR TFT PANEL 12:00 VIEW, LED BACKLIGHT, W/ TOUCH PANEL, -20°C TO +70°C OPERATING TEMP.	DRAWN BY: JN	CHECKED BY:
		APPROVED BY:	DATE: 06.08.09
			PAGE: 2 OF 11
			SCALE: N/A

UNCONTROLLED DOCUMENT

PART NUMBER	REV.
LCT-H800480M70W1T	

INTERFACE PIN CONNECTION		
PIN	NAME	DESCRIPTION
1	GND	POWER GROUND
2	GND	POWER GROUND
3	NC	NO CONNECTION
4	VCC	POWER SUPPLY FOR DIGITAL CIRCUIT
5	VCC	POWER SUPPLY FOR DIGITAL CIRCUIT
6	VCC	POWER SUPPLY FOR DIGITAL CIRCUIT
7	VCC	POWER SUPPLY FOR DIGITAL CIRCUIT
8	NC	NO CONNECTION
9	DE	DATA ENABLE
10	GND	POWER GROUND
11	GND	POWER GROUND
12	GND	POWER GROUND
13	B5	BLUE DATA INPUT (MSB)
14	B4	BLUE DATA INPUT
15	B3	BLUE DATA INPUT
16	GND	POWER GROUND
17	B2	BLUE DATA INPUT
18	B1	BLUE DATA INPUT
19	B0	BLUE DATA INPUT (LSB)
20	GND	POWER GROUND
21	G5	GREEN DATA INPUT (MSB)
22	G4	GREEN DATA INPUT
23	G3	GREEN DATA INPUT
24	GND	POWER GROUND
25	G2	GREEN DATA INPUT
26	G1	GREEN DATA INPUT
27	G0	GREEN DATA INPUT (LSB)
28	GND	POWER GROUND
29	R5	RED DATA INPUT (MSB)
30	R4	RED DATA INPUT
31	R3	RED DATA INPUT
32	GND	POWER GROUND
33	R2	RED DATA INPUT
34	R1	RED DATA INPUT
35	R0	RED DATA INPUT (LSB)
36	GND	POWER GROUND
37	GND	POWER GROUND
38	DCLK	SAMPLE CLOCK
39	GND	POWER GROUND
40	GND	POWER GROUND

BACKLIGHT UNIT			
PIN	NAME	DESCRIPTION	REMARK
1	LED+	HIGH VOLTAGE	WHITE LINE
2	LED-	LOW VOLTAGE	GRAY LINE

TOUCH PANEL PIN CONNECTION		
PIN	SYMBOL	FUNCTION
1	XR	TOUCH PANEL OUTPUT RIGHT
2	YD	TOUCH PANEL OUTPUT DOWN
3	XL	TOUCH PANEL OUTPUT LEFT
4	YU	TOUCH PANEL OUTPUT UPPER

UNCONTROLLED DOCUMENT

*UNLESS OTHERWISE SPECIFIED TOLERANCES PER DECIMAL PRECISION ARE: X=±1 (±0.039), X.X=±0.5 (±0.020), X.XX=±0.25 (±0.010), X.XXX=±0.127 (±0.005). LEAD SIZE=±0.05 (±0.002), LEAD LENGTH=±0.75 (±0.030). MIN.= +DECIMAL PRECISION -0.00, MAX.= +0.00 -DECIMAL PRECISION

REV.		PART NUMBER
		LCT-H800480M70W1T

CONFIDENTIAL INFORMATION
 THE INFORMATION CONTAINED IN THIS DOCUMENT IS THE PROPERTY OF LUMEX INC. EXCEPT AS SPECIFICALLY AUTHORIZED IN WRITING BY LUMEX INC., THE HOLDER OF THIS DOCUMENT SHALL KEEP ALL INFORMATION CONTAINED HEREIN CONFIDENTIAL AND SHALL PROTECT SAME IN WHOLE OR IN PART FROM DISCLOSURE AND DISSEMINATION TO ALL THIRD PARTIES.



290 E. HELEN ROAD
 PALATINE, IL 60067-6976
 PHONE: +1.847.359.2790
 US WEB: www.lumex.com
 TW WEB: www.lumex.com.tw

7.0" ACTIVE MATRIX FULL COLOR TFT PANEL
 12:00 VIEW, LED BACKLIGHT, W/ TOUCH PANEL,
 -20°C TO +70°C OPERATING TEMP.

RELIABILITY NOTE
 OUR MANY YEARS OF EXPERIENCE DATA ACCUMULATION INDICATE THAT SOLDER HEAT IS A MAJOR CAUSE OF EARLY AND FUTURE FAILURE. PLEASE PAY ATTENTION TO YOUR SOLDERING PROCESS.

DRAWN BY:	CHECKED BY:	APPROVED BY:	DATE: 06.08.09
JN			PAGE: 3 OF 11
			SCALE: N/A

INTERFACE TIMING							
SIGNAL	ITEM	SYMBOL	STANDARD VALUE			UNIT	NOTE
			MIN	TYP.	MAX		
CLOCK	FREQUENCY	FC	-	33.3	50	MHz	-
	PERIOD	Tc	-	30	25	ns	-
	HIGH TIME	Tch	12	-	-	ns	-
	LOW TIME	Tcl	13	-	-	ns	-
DATA	SETUP TIME	Tlvs	5	-	-	ns	-
	HOLD TIME	Tlvh	10	-	-	ns	-
VERTICAL ACTIVE DISPLAY TERM	FRAME RATE	Fr	-	60	72	Hz	Tv=Tvd+Tvb
	TOTAL	Tv	-	525	-	Th	-
	DISPLAY	Tvd	-	480	-	Th	-
	BLANK	Tvb	-	45	-	Th	-
HORIZONTAL ACTIVE DISPLAY TERM	TOTAL	Th	-	928	-	Tc	Th=Thd+Thb
	DISPLAY	Thd	-	800	-	Tc	-
	BLANK	Thb	-	128	-	Tc	-

NOTE (1): BECAUSE THIS MODULE IS OPERATED BY DE ONLY MODE, HSYNC AND VSYNC INPUT SIGNALS SHOULD BE SET TO LOW LOGIC LEVEL OR GROUND. OTHERWISE, THIS MODULE WOULD OPERATE ABNORMALLY.

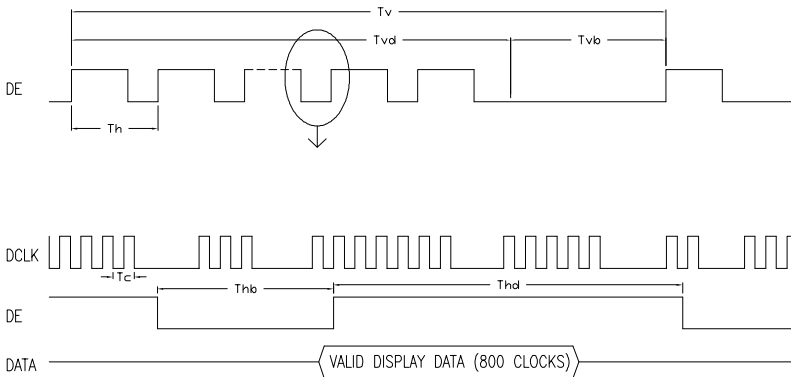

POWER ON/OFF SEQUENCE

TO PREVENT A LATCH-UP OR DC OPERATION OF LCD MODULE, THE POWER ON/OFF SEQUENCE SHOULD FOLLOW THE CONDITIONS SHOWN IN THE FOLLOWING DIAGRAM.

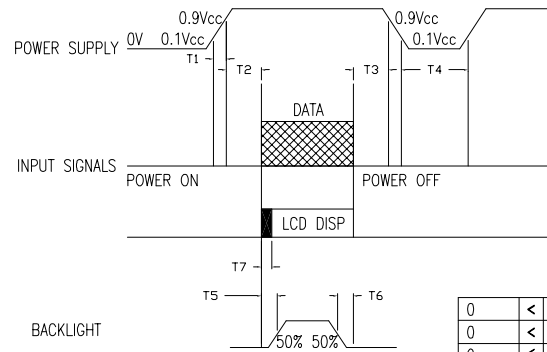

0	<	T1	≤	15 ms
0	<	T2	≤	20 sec
0	≤	T3	≤	1 sec
1 SEC	<	T4		
200 ms	≤	T5		
200 ms	≤	T6		

NOTES:

- (1) THE SUPPLY OF THE EXTERNAL SYSTEM FOR THE MODULE INPUT SHOULD BE THE SAME AS THE DEFINITION OF VCC.
- (2) PLEASE APPLY THE LAMP VOLTAGE WITHIN THE LCD OPERATION RANGE. WHEN THE BACKLIGHT TURNS ON BEFORE THE LCD OPERATION OF THE LCD TURNS OFF, THE DISPLAY MAY, INSTANTLY, FUNCTION ABNORMALLY.
- (3) IN CASE OF VCC=OFF LEVEL, PLEASE KEEP THE LEVEL OF INPUT SIGNALS ON THE LOW OR KEEP A HIGH IMPEDANCE.
- (4) T4 SHOULD BE MEASURED AFTER THE MODULE HAS BEEN FULLY DISCHARGED BETWEEN POWER ON/OFF PERIODS.
- (5) INTERFACE SIGNAL SHALL NOT BE KEPT AT HIGH IMPEDANCE WHEN THE POWER IS ON.

*UNLESS OTHERWISE SPECIFIED TOLERANCES PER DECIMAL PRECISION ARE: X=±1 (±0.039), X.X=±0.5 (±0.020), X.XX=±0.25 (±0.010), X.XXX=±0.127 (±0.005). LEAD SIZE=±0.05 (±0.002), LEAD LENGTH=±0.75 (±0.030). MIN.=+DECIMAL PRECISION -0.00 MAX.=+0.00 -DECIMAL PRECISION

REV.	PART NUMBER
	LCT-H800480M70W1T

CONFIDENTIAL INFORMATION
THE INFORMATION CONTAINED IN THIS DOCUMENT IS THE PROPERTY OF LUMEX INC. EXCEPT AS SPECIFICALLY AUTHORIZED IN WRITING BY LUMEX INC., THE HOLDER OF THIS DOCUMENT SHALL KEEP ALL INFORMATION CONTAINED HEREIN CONFIDENTIAL AND SHALL PROTECT SAME IN WHOLE OR IN PART FROM DISCLOSURE AND DISSEMINATION TO ALL THIRD PARTIES.



290 E. HELEN ROAD
PALATINE, IL 60067-6976
PHONE: +1.847.359.2790
US WEB: www.lumex.com
TW WEB: www.lumex.com.tw

7.0" ACTIVE MATRIX FULL COLOR TFT PANEL
12:00 VIEW, LED BACKLIGHT, W/ TOUCH PANEL,
-20°C TO +70°C OPERATING TEMP.

RELIABILITY NOTE
OUR MANY YEARS OF EXPERIENCE DATA ACCUMULATION INDICATE THAT SOLDER HEAT IS A MAJOR CAUSE OF EARLY AND FUTURE FAILURE. PLEASE PAY ATTENTION TO YOUR SOLDERING PROCESS.

DRAWN BY: JN	CHECKED BY:	APPROVED BY:	DATE: 06.08.09
			PAGE: 4 OF 11
			SCALE: N/A

DC CHARACTERISTICS		STANDARD VALUE			UNIT	NOTE
PARAMETER	SYMBOL	MIN	TYP.	MAX		
POWER SUPPLY VOLTAGE	VCC	+3.0	+3.3	+3.6	V	(1)
RIPPLE VOLTAGE	VRP	-	-	TBD	mV	-
RUSH CURRENT	IRUSH	-	-	TBD	A	(2)
POWER SUPPLY CURRENT	ICC	-	TBD	-	mV	(3)
TTL INPUT LOW VOLTAGE	VIL	0	-	0.3Vcc	V	(4)
TTL INPUT HIGH VOLTAGE	VIH	0.7Vcc	-	Vcc	V	(4)
TTL INPUT LEAK CURRENT (LOW)	IIL	-	-	TBD	mV	VI=0V(4)
TTL INPUT LEAK CURRENT (HIGH)	IiH	-	-	TBD	mV	VI=3.3V(4)

NOTE (1): THE MODULE IS RECOMMENDED TO OPERATE WITHIN SPECIFICATION RANGES LISTED ABOVE FOR NORMAL FUNCTION.
NOTE (2): MEASURED CONDITIONS:

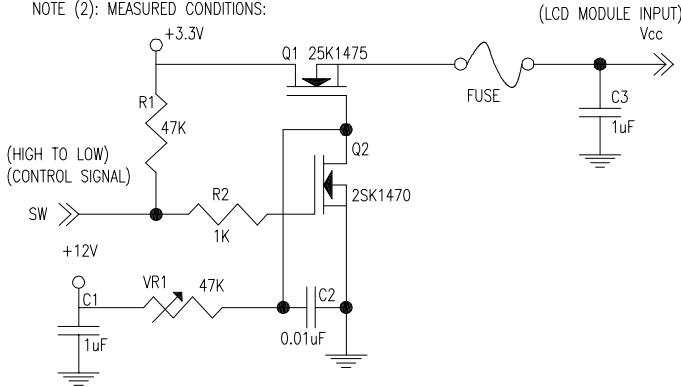

NOTE (3): THE SPECIFIED POWER SUPPLY CURRENT IS UNDER THE CONDITIONS AT Vcc=5.0V, Ta=25±2°C, fv=60Hz, WHEREAS A GRAY LEVEL VERTICAL STRIPE PATTERN IS DISPLAYED.
NOTE (4): CK, R0~R5, G0~G5, B0~B5, ENAB, HSYNC, VSYNC.

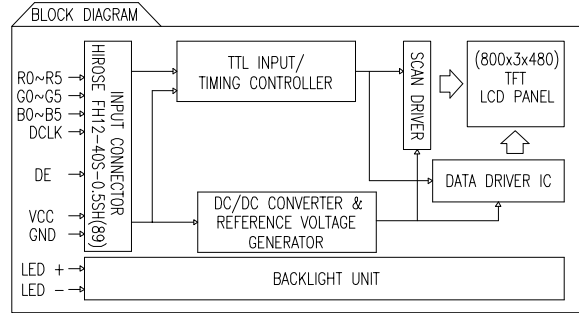

ABSOLUTE MAXIMUM RATINGS		STANDARD VALUE			UNIT	NOTE
ITEM	SYMBOL	MIN	TYP.	MAX		
POWER SUPPLY VOLTAGE	VCC	0	-	+6.0	V	(1)
LOGIC INPUT VOLTAGE	VIN	-0.3	-	+6.3	V	(1)
STORAGE TEMPERATURE	TST	-20	-	+70	°C	(2)
OPERATING AMBIENT TEMPERATURE	TOP	-30	-	+80	°C	(4),(3)

NOTE:
(1) PERMANENT DAMAGE MIGHT OCCUR IF THE MODULE IS OPERATED AT CONDITIONS EXCEEDING THE MAXIMUM VALUES.
(2) TEMPERATURE AND RELATIVE HUMIDITY RANGE IS SHOWN IN THE FIGURE BELOW.
(A) 95%RH MAX. (Ta≤40°C).
(B) WET-BULB TEMPERATURE SHOULD BE 39°C MAX. (Ta>40°C).
(C) NO CONDENSATION.
(3) THE TEMPERATURE OF PANEL SURFACE SHOULD BE 0°C MIN. AND 75°C MAX.
(4) IT IS A NORMAL CHARACTERISTIC THAT THE LCD COLOR AND CONTRAST WILL CHANGE (SOMETIMES UNEVENNESS CAN BE SEEN) UNDER LOW TEMPERATURE AND HIGH TEMPERATURE ENVIRONMENT. WHEN THE APPLICATION TEMPERATURE RETURNS BACK TO ROOM TEMPERATURE, LCD COLOR AND CONTRAST WILL REVERSE BACK TO ITS ORIGINAL COLOR AND CONTRAST WITHIN 24 HOURS AND ITS FUNCTIONALITY IS NOT AFFECTED.

*UNLESS OTHERWISE SPECIFIED TOLERANCES PER DECIMAL PRECISION ARE: X=±1 (±0.039), X.X=±0.5 (±0.020), X.XX=±0.25 (±0.010), X.XXX=±0.127 (±0.005). LEAD SIZE=±0.05 (±0.002), LEAD LENGTH=±0.75 (±0.030). MIN.=+DECIMAL PRECISION -0.00 MAX.=+0.00 -DECIMAL PRECISION

REV.	PART NUMBER LCT-H800480M70W1T	CONFIDENTIAL INFORMATION THE INFORMATION CONTAINED IN THIS DOCUMENT IS THE PROPERTY OF LUMEX INC. EXCEPT AS SPECIFICALLY AUTHORIZED IN WRITING BY LUMEX INC., THE HOLDER OF THIS DOCUMENT SHALL KEEP ALL INFORMATION CONTAINED HEREIN CONFIDENTIAL AND SHALL PROTECT SAME IN WHOLE OR IN PART FROM DISCLOSURE AND DISSEMINATION TO ALL THIRD PARTIES.	290 E. HELEN ROAD PALATINE, IL 60067-6976 PHONE: +1.847.359.2790 US WEB: www.lumex.com TW WEB: www.lumex.com.tw
7.0" ACTIVE MATRIX FULL COLOR TFT PANEL 12:00 VIEW, LED BACKLIGHT, W/ TOUCH PANEL, -20°C TO +70°C OPERATING TEMP.		RELIABILITY NOTE OUR MANY YEARS OF EXPERIENCE DATA ACCUMULATION INDICATE THAT SOLDER HEAT IS A MAJOR CAUSE OF EARLY AND FUTURE FAILURE. PLEASE PAY ATTENTION TO YOUR SOLDERING PROCESS.	DRAWN BY: JN CHECKED BY: APPROVED BY: DATE: 06.08.09 PAGE: 5 OF 11 SCALE: N/A

UNCONTROLLED DOCUMENT

PART NUMBER
LCT-H800480M70W1T

REV.

OPTICAL CHARACTERISTICS

ITEM	SYMBOL	CONDITION	STANDARD VALUE			UNIT	NOTE
			MIN	TYP.	MAX		
RESPONSE TIME	Tr	25°C	-	10	20	ms	1
	Tf	25°C	-	15	30	ms	
CONTRAST RATIO	CR	25°C	400	500	-	-	2
VIEWING ANGLE (CR2θ)	RIGHT	25°C	60	70	-	DEG	3,4
	LEFT	25°C	60	70	-	DEG	
	UPPER	25°C	40	50	-	DEG	
	LOWER	25°C	60	70	-	DEG	
LUMINANCE OF WHITE (CENTER POINT)	L	25°C	250	300	-	Cd/m ²	4
TRANSMISSIVE RATE	T%	25°C	-	7.3	-	%	4,5
COLOR CROMACITY (CIE1931)	Rx	25°C	TBD	TBD	TBD	-	NTSC =50%
	Ry						
Gx							
Gy							
Bx							
By							
Wx							
Wy							
OPTIMUM VIEWING DIRECTION	12 O'CLOCK						
LUMINANCE UNIFORMITY	Yu	25°C	70	80	-	%	4,5

NOTE(3): DEFINITION OF VIEWING ANGLE

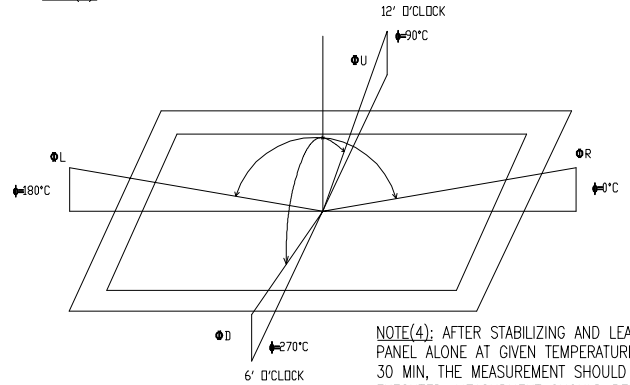

NOTE(4): AFTER STABILIZING AND LEAVING THE PANEL ALONE AT GIVEN TEMPERATURE FOR 30 MIN, THE MEASUREMENT SHOULD BE EXECUTED. MEASUREMENT SHOULD BE EXECUTED IN STABLE, WINDLESS, AND DARK ROOM 30 MINS AFTER LIGHTING THE BACKLIGHT. THIS SHOULD BE MEASURED IN THE CENTER OF SCREEN. ENVIRONMENT CONDITION: Ta=25±2°C BACK-LIGHT ON CONDITION

NOTE(5): DEFINITION OF LUMINANCE UNIFORMITY

ACTIVE AREA IS DIVIDED INTO 9 MEASURING AREAS. EVERY MEASURING POINT IS PLACED AT THE CENTER OF EACH MEASURING AREA. LUMINANCE UNIFORMITY (YU)= Bmin/Bmax
L-----ACTIVE AREA LENGTH W-----ACTIVE AREA WIDTH

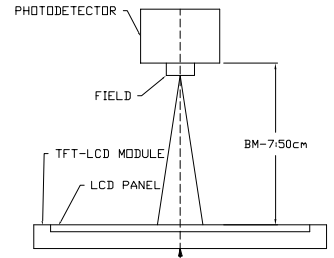
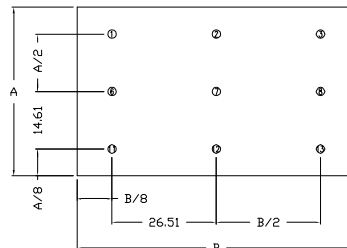

NOTE(1): DEFINITION OF RESPONSE TIME

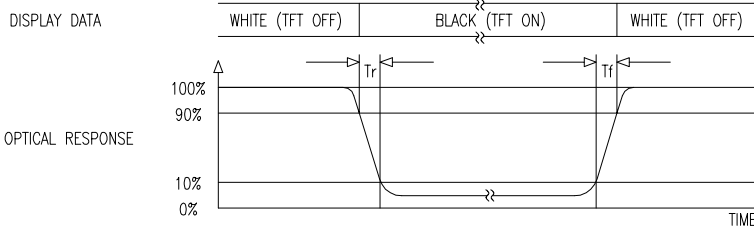

NOTE(2): DEFINITION OF CONTRAST RATIO

CR=BRIGHTNESS AT ALL PIXELS "WHITE" / BRIGHTNESS AT ALL PIXELS "BLACK"

*UNLESS OTHERWISE SPECIFIED TOLERANCES PER DECIMAL PRECISION ARE: X=±1 (±0.039), X.X=±0.5 (±0.020), X.XX=±0.25 (±0.010), X.XXX=±0.127 (±0.005), LEAD SIZE=±0.05 (±0.002), LEAD LENGTH=±0.75 (±0.030), MIN.=+DECIMAL PRECISION MAX.=+0.00 -DECIMAL PRECISION

UNCONTROLLED DOCUMENT

REV. PART NUMBER
LCT-H800480M70W1T

CONFIDENTIAL INFORMATION
THE INFORMATION CONTAINED IN THIS DOCUMENT IS THE PROPERTY OF LUMEX INC. EXCEPT AS SPECIFICALLY AUTHORIZED IN WRITING BY LUMEX INC., THE HOLDER OF THIS DOCUMENT SHALL KEEP ALL INFORMATION CONTAINED HEREIN CONFIDENTIAL AND SHALL PROTECT SAME IN WHOLE OR IN PART FROM DISCLOSURE AND DISSEMINATION TO ALL THIRD PARTIES.



290 E. HELEN ROAD
PALATINE, IL 60067-6976
PHONE: +1.847.359.2790
US WEB: www.lumex.com
TW WEB: www.lumex.com.tw

7.0" ACTIVE MATRIX FULL COLOR TFT PANEL
12:00 VIEW, LED BACKLIGHT, W/ TOUCH PANEL,
-20°C TO +70°C OPERATING TEMP.

RELIABILITY NOTE
OUR MANY YEARS OF EXPERIENCE DATA ACCUMULATION INDICATE THAT SOLDER HEAT IS A MAJOR CAUSE OF EARLY AND FUTURE FAILURE. PLEASE PAY ATTENTION TO YOUR SOLDERING PROCESS.

DRAWN BY: JN
CHECKED BY:
APPROVED BY:
DATE: 06.08.09
PAGE: 6 OF 11
SCALE: N/A

UNCONTROLLED DOCUMENT

PART NUMBER LCT-H800480M70W1T	REV.
---	------

STANDARD SPECIFICATION FOR REABILITY

STANDARD SPECIFICATION OF REABILITY TEST

NO	TEST ITEM	CONTENT OF TEST	TEST CONDITION	APPLICABLE STANDARD
1	HIGH TEMPERATURE STORAGE	ENDURANCE TEST APPLYING THE HIGH STORAGE TEMPERATURE FOR A LONG TIME.	80+/-3°C 240HRS	-----
2	LOW TEMPERATURE STORAGE	ENDURANCE TEST APPLYING THE LOW STORAGE TEMPERATURE FOR A LONG TIME.	-30+/-3°C 240HRS	-----
3	HIGH TEMPERATURE OPERATION	ENDURANCE TEST APPLYING THE ELECTRIC STRESS (VOLTAGE & CURRENT) AND THE THERMAL STRESS TO THE ELEMENT FOR A LONG TIME.	70+/-3°C 240HRS	-----
4	LOW TEMPERATURE OPERATION	ENDURANCE TEST APPLYING THE ELECTRIC STRESS UNDER LOW TEMPERATURE FOR A LONG TIME.	-20+/-3°C 240HRS	-----
5	HIGH TEMPERATURE/HUMIDITY OPERATION	ENDURANCE TEST APPLYING THE ELECTRIC STRESS (VOLTAGE & CURRENT) AND TEMPERATURE / HUMIDITY STRESS TO THE ELEMENT FOR A LONG TIME.	40°C, 90%RH 120HRS	MIL-202E-103B JIS-C5023
6	TEMPERATURE CYCLE	ENDURANCE TEST APPLYING THE LOW AND HIGH TEMPERATURE CYCLE. $\begin{matrix} -20^{\circ}\text{C} & \rightleftharpoons & 25^{\circ}\text{C} & \rightleftharpoons & 70^{\circ}\text{C} \\ \leftarrow 30 \text{ MIN} & & \leftarrow 5 \text{ MIN} & & \leftarrow 30 \text{ MIN.} \\ & & \text{1 CYCLE} & & \end{matrix}$	-20°C/ 70°C 10 CYCLES	-----
MECHANICAL TEST				
7	DROP TEST	ENDURANCE TEST APPLYING THE DROP DURING TRANSPORTATION.	PACKED,100cm FREE FALL(6 SIDES, 1 CORNER, 3 EDGES)	-----

REMARKS:

- FOR OPERATION TEST, ABOVE SPECIFICATION IS APPLICABLE WHEN TEST PATTERN IS CHANGING DURING ENTIRE OPERATION TEST.
- INSPECTIONS AFTER RELIABILITY TESTS ARE PERFORMED WHEN THE DISPLAY TEMPERATURE RESUMES BACK TO ROOM TEMPERATURE.
- IT IS A NORMAL CHARACTERISTIC THAT SOME DISPLAY ABNORMALITY CAN BE SEEN DURING REABILITY TEST. IF THE DISPLAY ABNORMALITY CAN RESUME BACK TO NORMAL CONDITION AT ROOM TEMPERATURE WITHIN 24 HOURS, THERE IS NO PERMANENT DESTRUCTION OVER THE DISPLAY. THE DISPLAY STILL POSSESSES ITS FUNCTIONALITY AFTER RELIABILITY TESTS.

UNCONTROLLED DOCUMENT

*UNLESS OTHERWISE SPECIFIED TOLERANCES PER DECIMAL PRECISION ARE: X=±1 (±0.039), X.X=±0.5 (±0.020), X.XX=±0.25 (±0.010), X.XXX=±0.127 (±0.005). LEAD SIZE=±0.05 (±0.002), LEAD LENGTH=±0.75 (±0.030). MIN.= +DECIMAL PRECISION MAX.= +0.00 -DECIMAL PRECISION

REV.	PART NUMBER LCT-H800480M70W1T	<p>CONFIDENTIAL INFORMATION</p> <p>THE INFORMATION CONTAINED IN THIS DOCUMENT IS THE PROPERTY OF LUMEX INC. EXCEPT AS SPECIFICALLY AUTHORIZED IN WRITING BY LUMEX INC., THE HOLDER OF THIS DOCUMENT SHALL KEEP ALL INFORMATION CONTAINED HEREIN CONFIDENTIAL AND SHALL PROTECT SAME IN WHOLE OR IN PART FROM DISCLOSURE AND DISSEMINATION TO ALL THIRD PARTIES.</p> <p style="text-align: center;">RELIABILITY NOTE</p> <p>OUR MANY YEARS OF EXPERIENCE DATA ACCUMULATION INDICATE THAT SOLDER HEAT IS A MAJOR CAUSE OF EARLY AND FUTURE FAILURE. PLEASE PAY ATTENTION TO YOUR SOLDERING PROCESS.</p>	 <p>LUMEX Creating LED and LCD Solutions Together™</p>	290 E. HELEN ROAD PALATINE, IL 60067-6976 PHONE: +1.847.359.2790 US WEB: www.lumex.com TW WEB: www.lumex.com.tw	
7.0" ACTIVE MATRIX FULL COLOR TFT PANEL 12:00 VIEW, LED BACKLIGHT, W/ TOUCH PANEL, -20°C TO +70°C OPERATING TEMP.		DRAWN BY: JN	CHECKED BY:	APPROVED BY:	DATE: 06.08.09 PAGE: 7 OF 11 SCALE: N/A

UNCONTROLLED DOCUMENT

PART NUMBER
LCT-H800480M70W1T

QUALITY ASSURANCE

ACCEPTABLE QUALITY LEVEL (AQL)

EACH LOT SHOULD SATISFY THE QUALITY LEVEL DEFINED AS FOLLOWS:

A. INSPECTION METHOD: MIL-SDT-105E LEVEL II NORMAL ONE TIME SAMPLING.

B. AQL LEVEL.

CATEGORY	AQL	DEFINITION
MAJOR	0.25%	FUNCTIONAL DEFECTIVE AS PRODUCT.
MINOR	1.00%	SATISFY ALL FUNCTIONS AS PRODUCT BUT NOT SATISFY COSMETIC STANDARD.

COSMETIC SCREENING CRITERIA

NO	DEFECT	JUDGMENT CRITERIA	CATEGORY
1	SPOTS/DUST /BUBBLE (ROUND TYPE)	SIZE, D(mm) D ≤ 0.15 ACCEPTABLE QUANTITY IN ACTIVE AREA 0.15 < D ≤ 0.20 DISREGARD D > 0.20 3 0	MINOR
2	DUST/ SCRATCHES/ BLACK STREAK (LINE TYPE)	WIDTH, W(mm) LENGTH, L(mm) IN ACTIVE AREA W ≤ 0.02 DISREGARD W ≤ 0.03 L ≤ 1.0 DISREGARD W ≤ 0.05 L ≤ 2.0 3 W > 0.05 DISREGARD 0	MINOR
3	ALLOWABLE DENSITY	ABOVE DEFECTS SHOULD BE SEPARATED MORE THAN 5mm EACH OTHER.	MINOR
4	RAINBOW	OBVIOUS UNVEN COLOR (RAINBOW) SHALL NOT BE NOTICEABLE.	MINOR
5	DISPLAY CONDITION	DIM DISPLAY ON THE PATTERNS, EXTRA PATTERN AND SHORT CIRCUIT ARE NOT ACCEPTABLE.	MAJOR
6	NO DISPLAY OR MISSING DISPLAY	THE PATTERNS OF DISPLAY SHALL LIGHT UP AS REQUIRED. NO DISPLAY OR MISSING DISPLAY ARE NOT ACCEPTABLE.	MAJOR

NOTE: D= (LONG LENGTH + SORTH LENGTH)/2

FAILURE JUDGMENT CRITERIA

AFTER REABILITY TEST ABOVE, TEST SAMPLE SHALL BE LET RETURN TO ROOM TEMPERATURE AND HUMIDITY AT LEAST 4 HOURS BEFORE FINAL TESTS ARE CARRIED OUT.

CRITERION ITEM	FAILURE JUDGMENT CRITERIA
ELECTRICAL CHARACTERISTIC	ELECTRICAL SHORT AND OPEN.
MECHANICAL CHARACTERISTIC	OUT OF MECHANICAL SPECIFICATION.
OPTICAL CHARACTERISTIC	OUT OF APPEARANCE STANDARD.

UNCONTROLLED DOCUMENT

*UNLESS OTHERWISE SPECIFIED TOLERANCES PER DECIMAL PRECISION ARE: X=±1 (±0.039), X.X=±0.5 (±0.020), X.XX=±0.25 (±0.010), X.XXX=±0.127 (±0.005). LEAD SIZE=±0.05 (±0.002), LEAD LENGTH=±0.75 (±0.030). MIN.= +DECIMAL PRECISION -0.00 MAX.= +0.00 -DECIMAL PRECISION

REV.	PART NUMBER LCT-H800480M70W1T	<p>CONFIDENTIAL INFORMATION</p> <p>THE INFORMATION CONTAINED IN THIS DOCUMENT IS THE PROPERTY OF LUMEX INC. EXCEPT AS SPECIFICALLY AUTHORIZED IN WRITING BY LUMEX INC., THE HOLDER OF THIS DOCUMENT SHALL KEEP ALL INFORMATION CONTAINED HEREIN CONFIDENTIAL AND SHALL PROTECT SAME IN WHOLE OR IN PART FROM DISCLOSURE AND DISSEMINATION TO ALL THIRD PARTIES.</p> <p>RELIABILITY NOTE</p> <p>OUR MANY YEARS OF EXPERIENCE DATA ACCUMULATION INDICATE THAT SOLDER HEAT IS A MAJOR CAUSE OF EARLY AND FUTURE FAILURE. PLEASE PAY ATTENTION TO YOUR SOLDERING PROCESS.</p>	 <p>290 E. HELEN ROAD PALATINE, IL 60067-6976 PHONE: +1.847.359.2790 US WEB: www.lumex.com TW WEB: www.lumex.com.tw</p>
7.0" ACTIVE MATRIX FULL COLOR TFT PANEL 12:00 VIEW, LED BACKLIGHT, W/ TOUCH PANEL, -20°C TO +70°C OPERATING TEMP.		DRAWN BY: JN	CHECKED BY: APPROVED BY: DATE: 06.08.09 PAGE: 8 OF 11 SCALE: N/A

UNCONTROLLED DOCUMENT

PRECAUTIONS FOR USING LCD MODULE

PART NUMBER
LCT-H800480M70W1T

REV.

HANDLING PRECAUTIONS

1. THE DISPLAY PANEL IS MADE OF GLASS AND POLARIZER. DO NOT SUBJECT IT TO MECHANICAL SHOCK BY DROPPING OR IMPACT WHICH MAY CAUSE CHIPPING ESPECIALLY ON THE EDGES.
2. DO NOT TOUCH, PUSH OR RUB THE EXPOSED POLARIZERS WITH ANYTHING HARDER THAN AN HB PENCIL LEAD (GLASS, TWEEZERS, ETC.). THE POLARIZER COVERING THE DISPLAY SURFACE OF THE LCD MODULE IS SOFT AND EASILY SCRATCHED. HANDLE THIS POLARIZER CAREFULLY.
3. IF THE DISPLAY SURFACE BECOMES CONTAMINATED, BREATHE ON THE SURFACE AND GENTLY WIPE IT WITH A SOFT DRY CLOTH. IF IT IS HEAVILY CONTAMINATED, MOISTEN CLOTH WITH ISOPROPYL ALCOHOL OR ETHYL ALCOHOL. AVOID USING SOLVENTS LIKE ACETONE (KETENE), WATER, TOLUENE, ETHANOL TO CLEAN THE POLARIZER SURFACE.
4. PLEASE KEEP THE TEMPERATURE WITHIN SPECIFIED RANGE FOR USE AND STORAGE. POLARIZATION DEGRADATION, BUBBLE GENERATION OR POLARIZER PEEL-OFF MAY OCCUR WITH HIGH TEMPERATURE AND HIGH HUMIDITY.
5. DO NOT APPLY EXCESSIVE FORCE TO THE DISPLAY SURFACE OR THE ADJOINING AREAS SINCE THIS MAY CAUSE THE COLOR TONE TO VARY.
6. INSTALL THE LCD MODULE BY USING THE MOUNTING HOLES. WHEN MOUNTING THE LCD MODULE MAKE SURE IT IS FREE OF TWISTING, WARPING AND DISTORTION.
7. EXERCISE CARE TO MINIMIZE CORROSION OF THE ELECTRODE. CORROSION OF THE ELECTRODES IS ACCELERATED BY WATER DROPLETS, MOISTURE CONDENSATION OR A CURRENT FLOW IN A HIGH-HUMIDITY ENVIRONMENT.
8. NC TERMINAL SHOULD BE OPEN. DO NOT CONNECT ANYTHING.
9. IF THE LOGIC CIRCUIT POWER IS OFF, DO NOT APPLY THE INPUT SIGNALS.
10. AVOID CONTACTING OIL AND FATS.
11. CONDENSATION ON THE SURFACE AND CONTACT WITH TERMINALS DUE TO COLD WILL DAMAGE, STAIN OR DIRTY THE POLARIZERS. AFTER PRODUCTS ARE TESTED AT LOW TEMPERATURE THEY MUST BE WARMED UP IN A CONTAINER BEFORE COMING IN CONTACT WITH ROOM TEMPERATURE AIR.
12. WIPE OFF SALIVA OR WATER DROPS IMMEDIATELY, CONTACT WITH WATER OVER A LONG PERIOD OF TIME MAY CAUSE DEFORMATION OR COLOR FADING.

PRECAUTION OF SOLDERING TO THE LCM

1. OBSERVE THE FOLLOWING WHEN SOLDERING LEAD WIRE, CONNECTOR CABLE AND ETC. TO THE LCD MODULE.
 - SOLDERING IRON TEMPERATURE: 300~350°C.
 - SOLDERING TIME: ≤ 3 SEC.
 - SOLDER: EUTECTIC SOLDER.
2. ABOVE IS A RECOMMENDED APPROACH. DUE TO DIFFERENT SOLDER COMPOSITION AND PROCESSING METHOD, IT IS RECOMMENDED THAT CUSTOMER TO STUDY AND FINE TUNING THEIR SOLDERING PROCESS PARAMETERS ACCORDINGLY.
3. IF SOLDERING FLUX IS USED, BE SURE TO REMOVE ANY REMAINING FLUX AFTER FINISHING TO SOLDERING OPERATION. (THIS DOES NOT APPLY IN THE CASE OF A NON-HALOGEN TYPE OF FLUX.) IT IS RECOMMENDED THAT YOU PROTECT THE LCD SURFACE WITH A COVER DURING SOLDERING TO PREVENT ANY DAMAGE DUE TO FLUX SPATTERS.

PRECAUTION FOR OPERATION

1. VIEWING ANGLE VARIES WITH THE CHANGE OF LIQUID CRYSTAL DRIVING VOLTAGE (V₀). ADJUST V₀ TO SHOW THE BEST CONTRAST.
2. DRIVING THE LCD IN THE VOLTAGE ABOVE THE LIMIT SHORTENS ITS LIFETIME.
3. RESPONSE TIME IS GREATLY DELAYED AT TEMPERATURE BELOW THE OPERATING TEMPERATURE RANGE. HOWEVER, IT WILL RECOVER WHEN IT RETURNS TO THE SPECIFIED TEMPERATURE RANGE.
4. IF THE DISPLAY AREA IS PUSHED HARD DURING OPERATION, THE DISPLAY WILL BECOME ABNORMAL. HOWEVER, IT WILL RETURN TO NORMAL IF IT IS TURNED OFF AND THEN BACK ON.
5. WHEN TURNING THE POWER ON, INPUT EACH SIGNAL AFTER THE POSITIVE/NEGATIVE VOLTAGE BECOMES STABLE (BELOW FIGURE IS A GENERAL ILLUSTRATION WHERE TYPICAL VALUE DEPENDS ON INDIVIDUAL PRODUCT DESIGN).

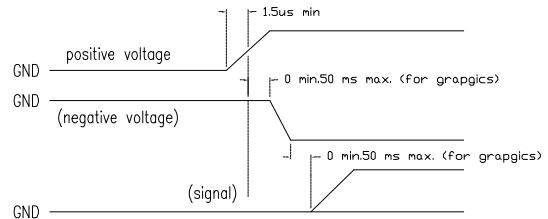

ELECTRO-STATIC DISCHARGE CONTROL

1. SINCE THIS MODULE USES A CMOS LSI, THE SAME CAREFUL ATTENTION SHOULD BE PAID TO ELECTROSTATIC DISCHARGE AS FOR AN ORDINARY CMOS IC.
2. BE SURE TO GROUND THE BODY WHEN HANDLING THE LCD MODULES. TOOLS REQUIRED FOR ASSEMBLING, SUCH AS SOLDERING IRONS, MUST BE PROPERLY GROUNDED.
3. TO REDUCE THE AMOUNT OF STATIC ELECTRICITY GENERATED, DO NOT CONDUCT ASSEMBLING AND OTHER WORK UNDER DRY CONDITIONS. TO REDUCE THE GENERATION OF STATIC ELECTRICITY, BE CAREFUL THAT THE AIR IN THE WORK IS NOT TOO DRIED. A RELATIVE HUMIDITY OF 50%-60% IS RECOMMENDED.
4. THE LCD MODULE IS COATED WITH A FILM TO PROTECT THE DISPLAY SURFACE. EXERCISE CARE WHEN PEELING OFF THIS PROTECTIVE FILM SINCE STATIC ELECTRICITY MAY BE GENERATED.
5. WHEN SOLDERING THE TERMINAL OF LCM, MAKE CERTAIN THE AC POWER SOURCE FOR THE SOLDERING IRON DOES NOT LEAK.

*UNLESS OTHERWISE SPECIFIED TOLERANCES PER DECIMAL PRECISION ARE: X=±1 (±0.039), X.X=±0.5 (±0.020), X.XX=±0.25 (±0.010), X.XXX=±0.127 (±0.005). LEAD SIZE=±0.05 (±0.002), LEAD LENGTH=±0.75 (±0.030). MIN.=+DECIMAL PRECISION MAX.=+0.00 -DECIMAL PRECISION

UNCONTROLLED DOCUMENT

REV.	PART NUMBER
	LCT-H800480M70W1T

CONFIDENTIAL INFORMATION
THE INFORMATION CONTAINED IN THIS DOCUMENT IS THE PROPERTY OF LUMEX INC. EXCEPT AS SPECIFICALLY AUTHORIZED IN WRITING BY LUMEX INC., THE HOLDER OF THIS DOCUMENT SHALL KEEP ALL INFORMATION CONTAINED HEREIN CONFIDENTIAL AND SHALL PROTECT SAME IN WHOLE OR IN PART FROM DISCLOSURE AND DISSEMINATION TO ALL THIRD PARTIES.



290 E. HELEN ROAD
PALATINE, IL 60067-6976
PHONE: +1.847.359.2790
US WEB: www.lumex.com
TW WEB: www.lumex.com.tw

7.0" ACTIVE MATRIX FULL COLOR TFT PANEL
12:00 VIEW, LED BACKLIGHT, W/ TOUCH PANEL,
-20°C TO +70°C OPERATING TEMP.

RELIABILITY NOTE
OUR MANY YEARS OF EXPERIENCE DATA ACCUMULATION INDICATE THAT SOLDER HEAT IS A MAJOR CAUSE OF EARLY AND FUTURE FAILURE. PLEASE PAY ATTENTION TO YOUR SOLDERING PROCESS.

DRAWN BY:
JN

CHECKED BY:

APPROVED BY:

DATE: 06.08.09
PAGE: 9 OF 11
SCALE: N/A

UNCONTROLLED DOCUMENT

PART NUMBER
LCT-H800480M70W1T

REV.

RoHS COMPLIANT PRODUCT

- | | |
|---|-------------------|
| 1. CADMIUM AND CADMIUM COMPOUNDS | LESS THAN 100PPM |
| 2. HEXAVALENT CHROMIUM COMPOUNDS | LESS THAN 1000PPM |
| 3. LEAD AND LEAD COMPOUNDS | LESS THAN 1000PPM |
| 4. MERCURY AND MERCURY COPMPOUNDS | LESS THAN 1000PPM |
| 5. POLYBROMINATED BIPHENYLS (PBBs) | LESS THAN 1000PPM |
| 6. POLYBROMINATED DIPHENYL ETHERS (PBDEs) | LESS THAN 1000PPM |

PACKAGING STANDARD

PRODUCT NO.	LCT-H800480M70W	RELEASE DATE	TBD
PRODUCT NAME.	7.0" TFT LCD MODULE	PREPARE BY:	
QUANTITY/ EACH BOX	TBD	BOX MATERIAL	PAPER CARTON
OUTER CARTON BOX SIZE	TBD	BOX TYPE	NEW
QUANTITY/ INNER BOX QUANTITY/ OUTER BOX	N/A	WEIGHT	N/A KG

THERE ARE 12 PCS LCD PER EACH ANTI-STATIC PLASTIC PLATE.
THERE ARE 7 LAYER PLASTIC PLATES PER EACH INNER CARTON BOX.
THERE ARE 2 INNER CARTON BOX PER EACH OUTER CARTON BOX.

STORAGE

- WHEN STORING LCDS AS SPARES FOR SOME YEARS, THE FOLLOWING PRECAUTIONS ARE NECESSARY.
- STORE THEM IN A SEALED POLYETHYLENE BAG. IF PROPERLY SEALED, THERE IS NO NEED FOR DESICCANT.
- STORE THEM IN A DARK PLACE. DO NOT EXPOSE TO SUNLIGHT OR FLUORESCENT LIGHT, KEEP THE TEMPERATURE BETWEEN 0°C AND 35°C.
- ENVIRONMENTAL CONDITIONS:
- DO NOT LEAVE THEM FOR MORE THAN 168HRS. AT 60°C.
- SHOULD NOT BE LEFT FOR MORE THAN 48HRS. AT -20°C.

SAFETY

- ITS RECOMMENDED TO CRUSH DAMAGED OR UNNECESSARY LCD INTO PIECES AND WASH THEM OFF WITH SOLVENTS SUCH AS ACETONE AND ETHANOL, WHICH SHOULD LATER BE BURNED.
- IF ANY LIQUID LEAKS OUT OF DAMAGED GLASS CELL AND COMES IN CONTACT WITH THE HANDS, WASH OFF THOROUGHLY WITH SOAP AND WATER.

UNCONTROLLED DOCUMENT

*UNLESS OTHERWISE SPECIFIED TOLERANCES PER DECIMAL PRECISION ARE: X=±1 (±0.039), X.X=±0.5 (±0.020), X.XX=±0.25 (±0.010), X.XXX=±0.127 (±0.005). LEAD SIZE=±0.05 (±0.002), LEAD LENGTH=±0.75 (±0.030). MIN.= +DECIMAL PRECISION -0.00, MAX.= +0.00 -DECIMAL PRECISION

REV.	PART NUMBER LCT-H800480M70W1T	<p>CONFIDENTIAL INFORMATION</p> <p>THE INFORMATION CONTAINED IN THIS DOCUMENT IS THE PROPERTY OF LUMEX INC. EXCEPT AS SPECIFICALLY AUTHORIZED IN WRITING BY LUMEX INC., THE HOLDER OF THIS DOCUMENT SHALL KEEP ALL INFORMATION CONTAINED HEREIN CONFIDENTIAL AND SHALL PROTECT SAME IN WHOLE OR IN PART FROM DISCLOSURE AND DISSEMINATION TO ALL THIRD PARTIES.</p> <p>RELIABILITY NOTE</p> <p>OUR MANY YEARS OF EXPERIENCE DATA ACCUMULATION INDICATE THAT SOLDER HEAT IS A MAJOR CAUSE OF EARLY AND FUTURE FAILURE. PLEASE PAY ATTENTION TO YOUR SOLDERING PROCESS.</p>	 <p>290 E. HELEN ROAD PALATINE, IL 60067-6976 PHONE: +1.847.359.2790 US WEB: www.lumex.com TW WEB: www.lumex.com.tw</p>		
7.0" ACTIVE MATRIX FULL COLOR TFT PANEL 12:00 VIEW, LED BACKLIGHT, W/ TOUCH PANEL, -20°C TO +70°C OPERATING TEMP.		DRAWN BY: JN	CHECKED BY:	APPROVED BY:	DATE: 06.08.09 PAGE: 10 OF 11 SCALE: N/A

UNCONTROLLED DOCUMENT

PART NUMBER
LCT-H800480M70W1T

REV.

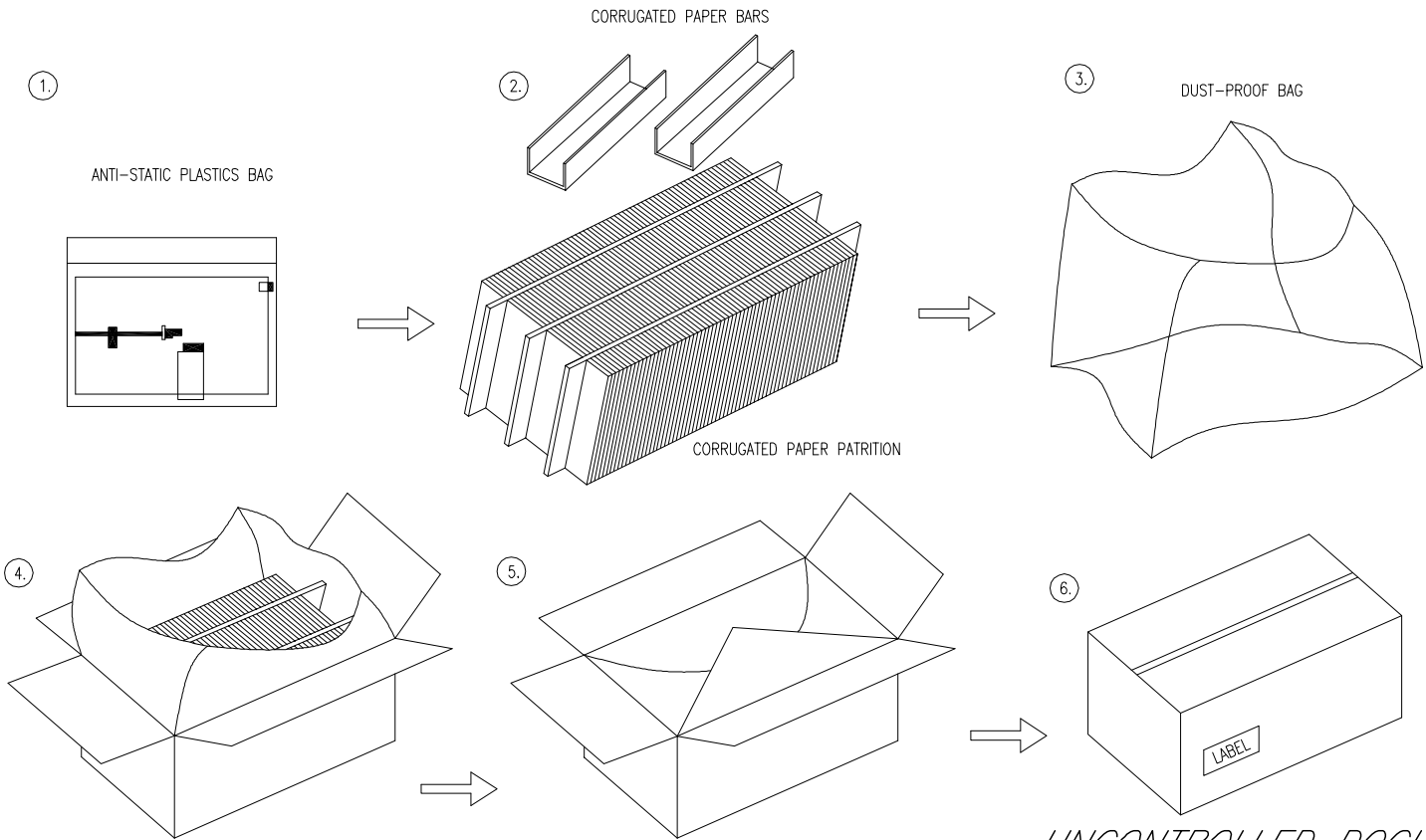

UNCONTROLLED DOCUMENT

*UNLESS OTHERWISE SPECIFIED TOLERANCES PER DECIMAL PRECISION ARE: X=±1 (±0.039), X.X=±0.5 (±0.020), X.XX=±0.25 (±0.010), X.XXX=±0.127 (±0.005). LEAD SIZE=±0.05 (±0.002), LEAD LENGTH=±0.75 (±0.030). MIN.= +DECIMAL PRECISION -0.00 MAX.= +0.00 -DECIMAL PRECISION

REV.	PART NUMBER
	LCT-H800480M70W1T

CONFIDENTIAL INFORMATION
THE INFORMATION CONTAINED IN THIS DOCUMENT IS THE PROPERTY OF LUMEX INC. EXCEPT AS SPECIFICALLY AUTHORIZED IN WRITING BY LUMEX INC., THE HOLDER OF THIS DOCUMENT SHALL KEEP ALL INFORMATION CONTAINED HEREIN CONFIDENTIAL AND SHALL PROTECT SAME IN WHOLE OR IN PART FROM DISCLOSURE AND DISSEMINATION TO ALL THIRD PARTIES.



290 E. HELEN ROAD
PALATINE, IL 60067-6976
PHONE: +1.847.359.2790
US WEB: www.lumex.com
TW WEB: www.lumex.com.tw

7.0" ACTIVE MATRIX FULL COLOR TFT PANEL
12:00 VIEW, LED BACKLIGHT, W/ TOUCH PANEL,
-20°C TO +70°C OPERATING TEMP.

RELIABILITY NOTE
OUR MANY YEARS OF EXPERIENCE DATA ACCUMULATION INDICATE THAT SOLDER HEAT IS A MAJOR CAUSE OF EARLY AND FUTURE FAILURE. PLEASE PAY ATTENTION TO YOUR SOLDERING PROCESS.

DRAWN BY:
JN

CHECKED BY:

APPROVED BY:

DATE: 06.08.09
PAGE: 11 OF 11
SCALE: N/A