

## Standard Hybrid Step Motors

# 17PY-Z

17PY-XXXX (42□ 0.9°)

Model	Length	UNIT:mm
17PY-X0XX	34	
17PY-X8XX	40	
17PY-X4XX	48	

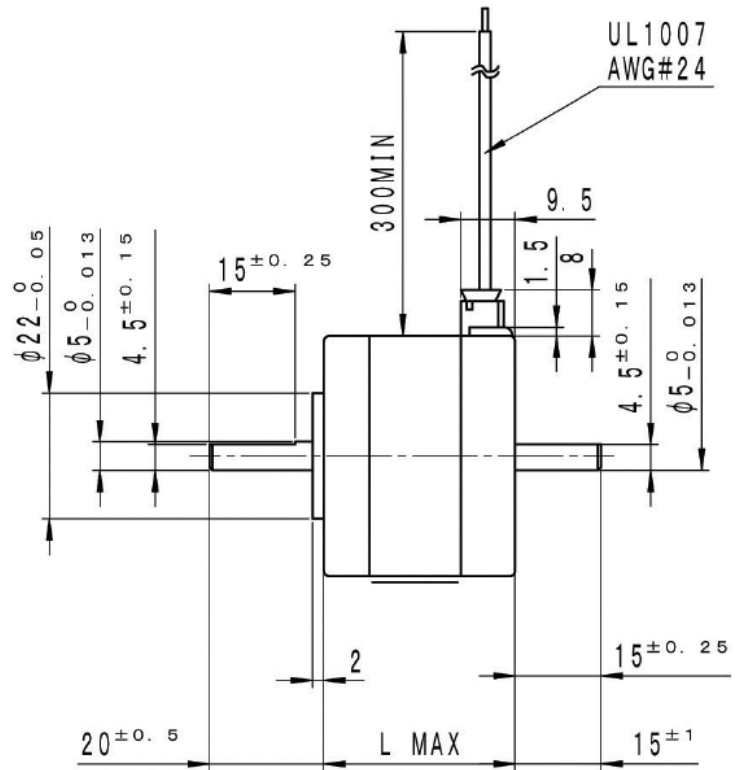
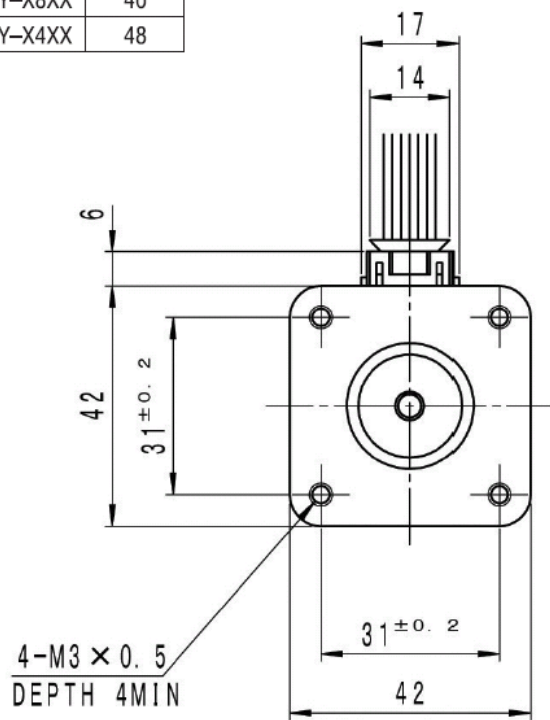

# 17PY-Z

Part Number	Motor Size [mm]	Step Angle [deg]	Rated Current [A]	Resistance [Ohms]	Holding Torque [mNm]	Mass [g]
17PY-Z053-00VS/99VS	42 ~ 34	0.9	0.85	4.2	160	200
17PY-Z845-00VS/99VS	42 ~ 40	0.9	1.2	2.9	260	300
17PY-Z858-00VS/99VS	42 ~ 40	0.9	0.75	7.4	260	300
17PY-Z444-00VS/99VS	42 ~ 48	0.9	1.2	3.3	330	350
17PY-Z455-00VS/99VS	42 ~ 48	0.9	0.8	7.3	330	350

**Model No : 17PY-Z053U,Z845U,Z858U,Z444U,Z455U**  
**Driver : Chopper Dual**  
**Supply Voltage : 24.0 (volt)**

