

Standard Hybrid Step Motors

17PM-K

17PM-XXXX (42□ 1.8°)

Model	Length	UNIT:mm
17PM-X0XX	34	
17PM-X8XX	40	
17PM-X4XX	48	

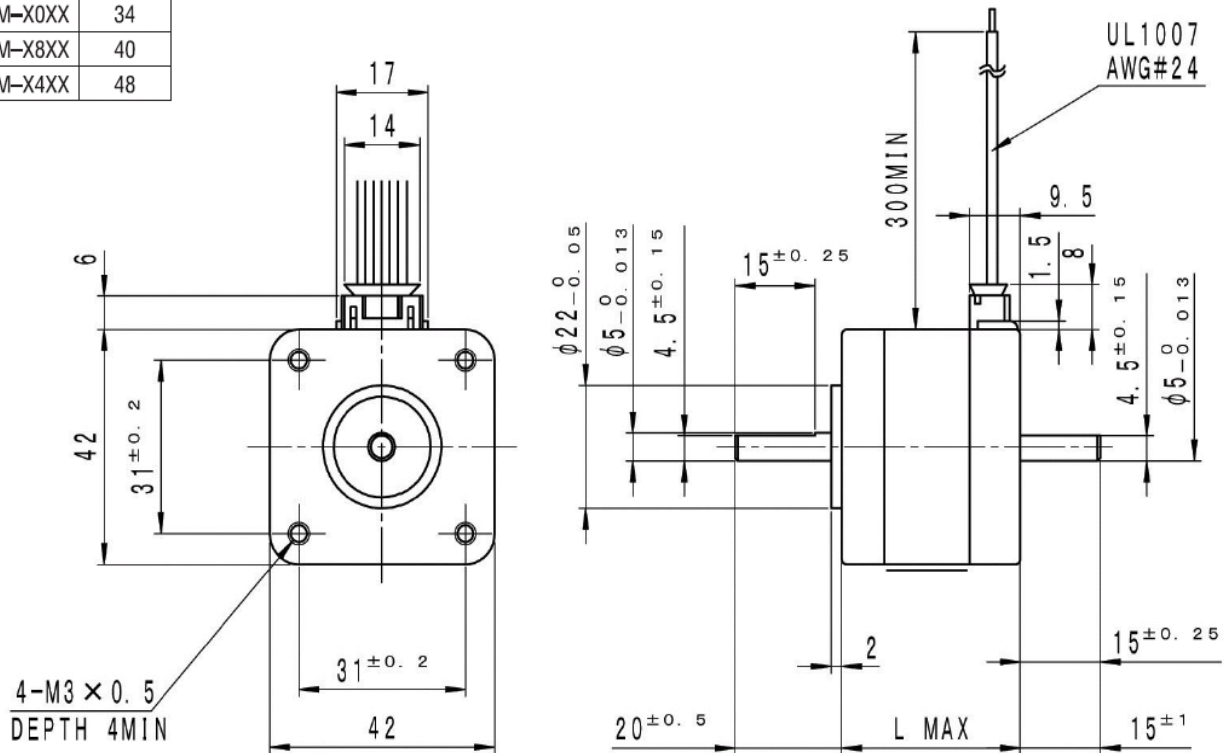

17PM-K

Part Number	Motor Size	Step Angle [deg]	Rated Current [A]	Resistance [Ohms]	Holding Torque [mNm]	Mass [g]
	[mm]					
17PM-K053-00VS/99VS	42 ~ 34	1.8	0.85	4.2	170	200
17PM-K845-00VS/99VS	42 ~ 40	1.8	1.2	2.9	270	300
17PM-K858-00VS/99VS	42 ~ 40	1.8	0.75	7.4	270	300
17PM-K444-00VS/99VS	42 ~ 48	1.8	1.2	3.3	340	350
17PM-K455-00VS/99VS	42 ~ 4 8	1.8	0.8	7.3	340	350

Model No : 17PM-K053U,K845U,K858U,K444U,K455U
 Driver : Chopper Dual
 Supply Voltage : 24.0 (volt)

