

LMP8640/LMP8640HV

Precision High Voltage Current Sense Amplifier

General Description

The LMP8640 and the LMP8640HV are precision current sense amplifiers that detect small differential voltages across a sense resistor in the presence of high input common mode voltages with a supply voltage range from 2.7V to 12V.

The LMP8640 accepts input signals with common mode voltage range from -2V to 42V, while the LMP8640HV accepts input signal with common mode voltage range from -2V to 76V. The LMP8640 and LMP8640HV have fixed gain for applications that demand accuracy over temperature. The LMP8640 and LMP8640HV come out with three different fixed gains 20V/V, 50V/V, 100V/V ensuring a gain accuracy as low as 0.25%. The output is buffered in order to provide low output impedance. This high side current sense amplifier is ideal for sensing and monitoring currents in DC or battery powered systems, excellent AC and DC specifications over temperature, and keeps errors in the current sense loop to a minimum. The LMP8640 and LMP8640HV are ideal choice for industrial, automotive and consumer applications, and it is available in TSOT-6 package.

Features

Typical values, $T_A = 25^\circ\text{C}$

- High common-mode voltage range
 - LMP8640 -2V to 42V
 - LMP8640HV -2V to 76V
- Supply voltage range 2.7V to 12V
- Gain options 20V/V; 50V/V; 100V/V
- Max gain error 0.25%
- Low offset voltage 900 μV
- Input bias current 13 μA
- PSRR 85 dB
- CMRR (2.1V to 42V) 103 dB
- Temperature range -40°C to 125°C
- 6-Pin TSOT Package

Applications

- High-side current sense
- Vehicle current measurement
- Motor controls
- Battery monitoring
- Remote sensing
- Power management

Typical Application

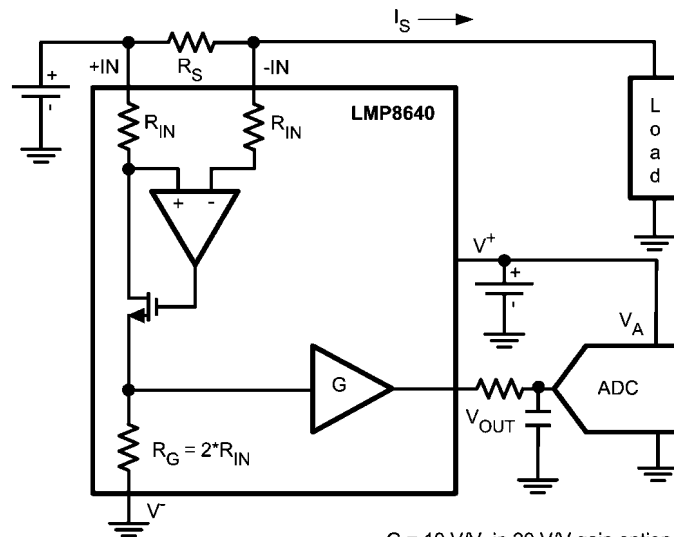

$G = 10 \text{ V/V}$ in 20 V/V gain option
 $G = 25 \text{ V/V}$ in 50 V/V gain option
 $G = 50 \text{ V/V}$ in 100 V/V gain option

30071462

Absolute Maximum Ratings *(Note 1)*

If Military/Aerospace specified devices are required, please contact the National Semiconductor Sales Office/Distributors for availability and specifications.

ESD Tolerance *(Note 2)*

| | |
|--------------------------------------|------------|
| Human Body Model | |
| For input pins +IN, -IN | 5000V |
| For all other pins | 2000V |
| Machine Model | 200V |
| Charge device model | 1250V |
| Supply Voltage ($V_S = V^+ - V^-$) | 13.2V |
| Differential Voltage +IN- (-IN) | 6V |
| Voltage at pins +IN, -IN | |
| LMP8640HV | -6V to 80V |

| | |
|--|----------------|
| LMP8640 | -6V to 60V |
| Voltage at V_{OUT} pin | V^- to V^+ |
| Storage Temperature Range | -65°C to 150°C |
| Junction Temperature <i>(Note 3)</i> | 150°C |
| For soldering specifications, | |
| see product folder at www.national.com and | |
| www.national.com/ms/MS/MS-SOLDERING.pdf | |

Operating Ratings *(Note 1)*

| | |
|--|----------------|
| Supply Voltage ($V_S = V^+ - V^-$) | 2.7V to 12V |
| Temperature Range <i>(Note 3)</i> | -40°C to 125°C |
| Package Thermal Resistance <i>(Note 3)</i> | |
| TSOT-6 | 96°C/W |

2.7V Electrical Characteristics *(Note 4)*

Unless otherwise specified, all limits guaranteed for at $T_A = 25^\circ\text{C}$, $V_S = V^+ - V^-$, $V_{SENSE} = +IN(-IN)$, $V^+ = 2.7\text{V}$, $V^- = 0\text{V}$, $-2\text{V} < V_{CM} < 76\text{V}$, $R_L = 10\text{M}\Omega$. **Boldface** limits apply at the temperature extremes.

| Symbol | Parameter | Condition | Min <i>(Note 6)</i> | Typ <i>(Note 5)</i> | Max <i>(Note 6)</i> | Units |
|------------|---|---|------------------------|------------------------|------------------------|------------------------------|
| V_{OS} | Input Offset Voltage | $V_{CM} = 2.1\text{V}$ | -900 -1160 | | 900 1160 | μV |
| TCV_{OS} | Input Offset Voltage Drift <i>(Note 7, Note 9)</i> | $V_{CM} = 2.1\text{V}$ | | | 2.6 | $\mu\text{V}/^\circ\text{C}$ |
| I_B | Input Bias Current <i>(Note 10)</i> | $V_{CM} = 2.1\text{V}$ | | 12 | 20 27 | μA |
| e_{ni} | Input Voltage Noise <i>(Note 9)</i> | $f > 10\text{ kHz}$ | | 117 | | $\text{nV}/\sqrt{\text{Hz}}$ |
| Gain A_V | Fixed Gain LMP8640-T LMP8640HV-T | | | 20 | | V/V |
| | Fixed Gain LMP8640-F LMP8640HV-F | | | 50 | | V/V |
| | Fixed Gain LMP8640-H LMP8640HV-H | | | 100 | | V/V |
| | Gain error | $V_{CM} = 2.1\text{V}$ | -0.25 -0.51 | | 0.25 0.51 | % |
| | Accuracy over temperature <i>(Note 9)</i> | -40°C to 125°C , $V_{CM} = 2.1\text{V}$ | | | 26.2 | $\text{ppm}/^\circ\text{C}$ |
| PSRR | Power Supply Rejection Ratio | $V_{CM} = 2.1\text{V}$, $2.7\text{V} < V^+ < 12\text{V}$, | 85 | | | dB |
| CMRR | Common Mode Rejection Ratio | LMP8640HV $2.1\text{V} < V_{CM} < 42\text{V}$ | 103 | | | dB |
| | | LMP8640 $2.1\text{V} < V_{CM} < 42\text{V}$ | | | | |
| | | LMP8640HV $2.1\text{V} < V_{CM} < 76\text{V}$ | 95 | | | |
| | | $-2\text{V} < V_{CM} < 2\text{V}$, | 60 | | | |
| BW | Fixed Gain LMP8640-T LMP8640HV-T <i>(Note 9)</i> | DC $V_{SENSE} = 67.5\text{ mV}$, $C_L = 30\text{ pF}$, $R_L = 1\text{M}\Omega$ | | 950 | | kHz |
| | Fixed Gain LMP8640-F LMP8640HV-F <i>(Note 9)</i> | DC $V_{SENSE} = 27\text{ mV}$, $C_L = 30\text{ pF}$, $R_L = 1\text{M}\Omega$ | | 450 | | |
| | Fixed Gain LMP8640-H LMP8640HV-H <i>(Note 9)</i> | DC $V_{SENSE} = 13.5\text{ mV}$, $C_L = 30\text{ pF}$, $R_L = 1\text{M}\Omega$ | | 230 | | |
| SR | Slew Rate <i>(Note 8, Note 9)</i> | $V_{CM} = 5\text{V}$, $C_L = 30\text{ pF}$, $R_L = 1\text{M}\Omega$, LMP8640-T LMP8640HV-T $V_{SENSE} = 100\text{mVpp}$, LMP8640-F LMP8640HV-F $V_{SENSE} = 40\text{mVpp}$, LMP8640-H LMP8640HV-H $V_{SENSE} = 20\text{mVpp}$, | | 1.4 | | V/ μs |

| Symbol | Parameter | Condition | Min (Note 6) | Typ (Note 5) | Max (Note 6) | Units |
|------------|---|--|-----------------|-----------------|---------------------|------------|
| R_{IN} | Differential Mode Input Impedance (Note 9) | | | 5 | | k Ω |
| I_S | Supply Current | $V_{CM} = 2.1V$ | | 420 | 600 800 | μA |
| | | $V_{CM} = -2V$ | | 2000 | 2500 2750 | |
| V_{OUT} | Maximum Output Voltage | $V_{CM} = 2.1V$ | 2.65 | | | V |
| | Minimum Output Voltage | LMP8640-T LMP8640HV-T $V_{CM} = 2.1V$ | | | 18.2 | mV |
| | | LMP8640-F LMP8640HV-F $V_{CM} = 2.1V$ | | | 40 | |
| | | LMP8640-H LMP8640HV-H $V_{CM} = 2.1V$ | | | 80 | |
| C_{LOAD} | Max Output Capacitance Load (Note 9) | | | 30 | | pF |

5V Electrical Characteristics (Note 4)

Unless otherwise specified, all limits guaranteed for at $T_A = 25^\circ C$, $V_S = V^+ - V^-$, $V_{SENSE} = +IN - (-IN)$, $V^+ = 5V$, $V^- = 0V$, $-2V < V_{CM} < 76V$, $R_L = 10M\Omega$. **Boldface** limits apply at the temperature extremes.

| Symbol | Parameter | Condition | Min (Note 6) | Typ (Note 5) | Max (Note 6) | Units |
|------------|--|--|-----------------------|-----------------|---------------------|------------------|
| V_{OS} | Input Offset Voltage | $V_{CM} = 2.1V$ | -900 -1160 | | 900 1160 | μV |
| TCV_{OS} | Input Offset Voltage Drift (Note 7, Note 9) | $V_{CM} = 2.1V$ | | | 2.6 | $\mu V/^\circ C$ |
| I_B | Input Bias Current (Note 10) | $V_{CM} = 2.1V$ | | 13 | 21 28 | μA |
| e_{ni} | Input Voltage Noise (Note 9) | $f > 10 kHz$ | | 117 | | nV/\sqrt{Hz} |
| Gain A_V | Fixed Gain LMP8640-T LMP8640HV-T | | | 20 | | V/V |
| | Fixed Gain LMP8640-F LMP8640HV-F | | | 50 | | V/V |
| | Fixed Gain LMP8640-H LMP8640HV-H | | | 100 | | V/V |
| | Gain error | $V_{CM} = 2.1V$ | -0.25 -0.51 | | 0.25 0.51 | % |
| | Accuracy over temperature (Note 9) | $-40^\circ C$ to $125^\circ C$, $V_{CM} = 2.1V$ | | | 26.2 | ppm/ $^\circ C$ |
| PSRR | Power Supply Rejection Ratio | $V_{CM} = 2.1V$, $2.7V < V^+ < 12V$, | 85 | | | dB |
| CMRR | Common Mode Rejection Ratio | LMP8640HV $2.1V < V_{CM} < 42V$ | 103 | | | dB |
| | | LMP8640 $2.1V < V_{CM} < 42V$ | | | | |
| | | LMP8640HV $2.1V < V_{CM} < 76V$ $-2V < V_{CM} < 2V$, | 95 60 | | | |
| BW | Fixed Gain LMP8640-T LMP8640HV-T (Note 9) | DC $V_{SENSE} = 67.5 mV$, $C_L = 30 pF$, $R_L = 1M\Omega$ | | 950 | | kHz |
| | Fixed Gain LMP8640-F LMP8640HV-F (Note 9) | DC $V_{SENSE} = 27 mV$, $C_L = 30 pF$, $R_L = 1M\Omega$ | | 450 | | |
| | Fixed Gain LMP8640-H LMP8640HV-H (Note 9) | DC $V_{SENSE} = 13.5 mV$, $C_L = 30 pF$, $R_L = 1M\Omega$ | | 230 | | |

| Symbol | Parameter | Condition | Min (Note 6) | Typ (Note 5) | Max (Note 6) | Units |
|--|---|---|-----------------|-----------------|---------------------|------------|
| SR | Slew Rate (Note 8, Note 9) | $V_{CM} = 5V$, $C_L = 30$ pF, $R_L = 1M\Omega$, LMP8640-T LMP8640HV-T $V_{SENSE} = 200mV_{pp}$, LMP8640-F LMP8640HV-F $V_{SENSE} = 80mV_{pp}$, LMP8640-H LMP8640HV-H $V_{SENSE} = 40mV_{pp}$, | | 1.6 | | V/ μ s |
| R_{IN} | Differential Mode Input Impedance (Note 9) | | | 5 | | k Ω |
| I_S | Supply Current | $V_{CM} = 2.1V$ | | 500 | 722 922 | μ A |
| | | $V_{CM} = -2V$ | | 2050 | 2500 2750 | |
| V_{OUT} | Maximum Output Voltage | $V_{CM} = 2.1V$ | 4.95 | | | V |
| | Minimum Output Voltage | LMP8640-T LMP8640HV-T $V_{CM} = 2.1V$ | | | 18.2 | mV |
| | | LMP8640-F LMP8640HV-F $V_{CM} = 2.1V$ | | | 40 | |
| LMP8640-H LMP8640HV-H $V_{CM} = 2.1V$ | | | | 80 | | |
| C_{LOAD} | Max Output Capacitance Load (Note 9) | | | 30 | | pF |

12V Electrical Characteristics (Note 4)

Unless otherwise specified, all limits guaranteed for at $T_A = 25^\circ C$, $V_S = V^+ - V^-$, $V_{SENSE} = +IN - (-IN)$, $V^+ = 12V$, $V^- = 0V$, $-2V < V_{CM} < 76V$, $R_L = 10M\Omega$. **Boldface** limits apply at the temperature extremes.

| Symbol | Parameter | Condition | Min (Note 6) | Typ (Note 5) | Max (Note 6) | Units |
|------------|--|--|-----------------------|-----------------|---------------------|---------------------|
| V_{OS} | Input Offset Voltage | $V_{CM} = 2.1V$ | -900 -1160 | | 900 1160 | μ V |
| TCV_{OS} | Input Offset Voltage Drift (Note 7, Note 9) | $V_{CM} = 2.1V$ | | | 2.6 | μ V/ $^\circ$ C |
| I_B | Input Bias Current (Note 10) | $V_{CM} = 2.1V$ | | 13 | 22 28 | μ A |
| e_{ni} | Input Voltage Noise (Note 9) | $f > 10$ kHz | | 117 | | nV/ \sqrt{Hz} |
| Gain A_V | Fixed Gain LMP8640-T LMP8640HV-T | | | 20 | | V/V |
| | Fixed Gain LMP8640-F LMP8640HV-F | | | 50 | | V/V |
| | Fixed Gain LMP8640-H LMP8640HV-H | | | 100 | | V/V |
| | Gain error | $V_{CM} = 2.1V$ | -0.25 -0.51 | | 0.25 0.51 | % |
| | Accuracy over temperature (Note 9) | $-40^\circ C$ to $125^\circ C$, $V_{CM} = 2.1V$ | | | 26.2 | ppm/ $^\circ$ C |
| PSRR | Power Supply Rejection Ratio | $V_{CM} = 2.1V$, $2.7V < V^+ < 12V$, | 85 | | | dB |
| CMRR | Common Mode Rejection Ratio | LMP8640HV $2.1V < V_{CM} < 42V$ | 103 | | | dB |
| | | LMP8640 $2.1V < V_{CM} < 42V$ | | | | |
| | | LMP8640HV $2.1V < V_{CM} < 76V$ | 95 | | | |
| | | $-2V < V_{CM} < 2V$, | 60 | | | |

| Symbol | Parameter | Condition | Min (Note 6) | Typ (Note 5) | Max (Note 6) | Units | |
|------------|---|--|-----------------|-----------------|---------------------|------------------|----|
| BW | Fixed Gain LMP8640-T LMP8640HV-T (Note 9) | DC $V_{SENSE} = 67.5 \text{ mV}$, $C_L = 30 \text{ pF}$, $R_L = 1 \text{ M}\Omega$ | | 950 | | kHz | |
| | Fixed Gain LMP8640-F LMP8640HV-F (Note 9) | DC $V_{SENSE} = 27 \text{ mV}$, $C_L = 30 \text{ pF}$, $R_L = 1 \text{ M}\Omega$ | | 450 | | | |
| | Fixed Gain LMP8640-H LMP8640HV-H (Note 9) | DC $V_{SENSE} = 13.5 \text{ mV}$, $C_L = 30 \text{ pF}$, $R_L = 1 \text{ M}\Omega$ | | 230 | | | |
| SR | Slew Rate (Note 8, Note 9) | $V_{CM} = 5 \text{ V}$, $C_L = 30 \text{ pF}$, $R_L = 1 \text{ M}\Omega$, LMP8640-T LMP8640HV-T $V_{SENSE} = 500 \text{ mVpp}$, LMP8640-F LMP8640HV-F $V_{SENSE} = 200 \text{ mVpp}$, LMP8640-H LMP8640HV-H $V_{SENSE} = 100 \text{ mVpp}$, | | 1.8 | | V/ μs | |
| R_{IN} | Differential Mode Input Impedance (Note 9) | | | 5 | | k Ω | |
| I_S | Supply Current | $V_{CM} = 2.1 \text{ V}$ | | 720 | 1050 1250 | μA | |
| | | $V_{CM} = -2 \text{ V}$ | | 2300 | 2800 3000 | | |
| V_{OUT} | Maximum Output Voltage | $V_{CM} = 2.1 \text{ V}$ | 11.85 | | | V | |
| | Minimum Output Voltage | LMP8640-T LMP8640HV-T $V_{CM} = 2.1 \text{ V}$ | | | 18.2 | mV | |
| | | LMP8640-F LMP8640HV-F $V_{CM} = 2.1 \text{ V}$ | | | | | 40 |
| | | LMP8640-H LMP8640HV-H $V_{CM} = 2.1 \text{ V}$ | | | | | 80 |
| C_{LOAD} | Max Output Capacitance Load (Note 9) | | | 30 | | pF | |

Note 1: "Absolute Maximum Ratings" indicate limits beyond which damage to the device may occur, including inoperability and degradation of device reliability and/or performance. Functional operation of the device and/or non-degradation at the Absolute Maximum Ratings or other conditions beyond those indicated in the Operating Ratings is not implied. Operating Ratings indicate conditions at which the device is functional and the device should not be operated beyond such conditions.

Note 2: Human Body Model, applicable std. MIL-STD-883, Method 3015.7. Machine Model, applicable std. JESD22-A115-A (ESD MM std. of JEDEC) Field-Induced Charge-Device Model, applicable std. JESD22-C101-C (ESD FICDM std. of JEDEC).

Note 3: The maximum power dissipation must be derated at elevated temperatures and is dictated by $T_{J(MAX)}$, θ_{JA} , and the ambient temperature, T_A . The maximum allowable power dissipation $P_{D(MAX)} = (T_{J(MAX)} - T_A) / \theta_{JA}$ or the number given in Absolute Maximum Ratings, whichever is lower.

Note 4: Electrical Table values apply only for factory testing conditions at the temperature indicated. Factory testing conditions result in very limited self-heating of the device such that $T_J = T_A$. No guarantee of parametric performance is indicated in the electrical tables under conditions of internal self-heating where $T_J > T_A$. Absolute Maximum Ratings indicate junction temperature limits beyond which the device may be permanently degraded, either mechanically or electrically.

Note 5: Typical values represent the most likely parametric norm at the time of characterization. Actual typical values may vary over time and will also depend on the application and configuration. The typical values are not tested and are not guaranteed on shipped production material.

Note 6: Limits are 100% production tested at 25°C. Limits over the operating temperature range are guaranteed through correlations using statistical quality control (SQC) method.

Note 7: Offset voltage temperature drift is determined by dividing the change in V_{OS} at the temperature extremes by the total temperature change.

Note 8: The number specified is the average of rising and falling slew rates and measured at 90% to 10%.

Note 9: This parameter is guaranteed by design and/or characterization and is not tested in production.

Note 10: Positive Bias Current corresponds to current flowing into the device.

Block Diagram

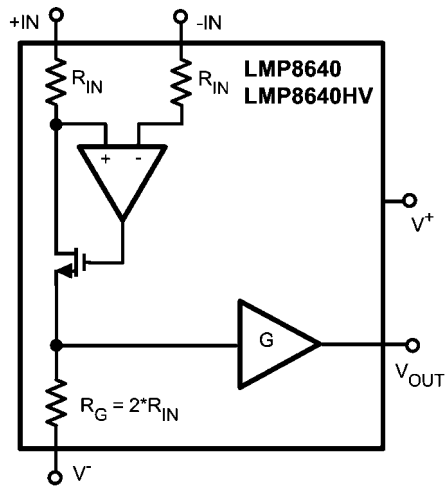

Connection Diagram

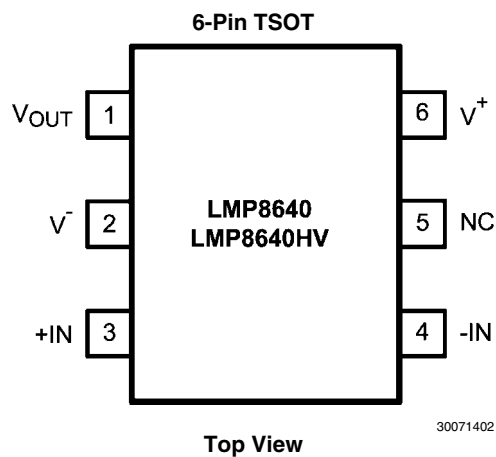

Pin Descriptions

| Pin | Name | Description |
|-----|-----------|-------------------------|
| 1 | V_{OUT} | Single Ended Output |
| 2 | V^- | Negative Supply Voltage |
| 3 | +IN | Positive Input |
| 4 | -IN | Negative Input |
| 5 | NC | Not Connected |
| 6 | V^+ | Positive Supply Voltage |

Ordering Information

| Package | Gain | Part Number | Package Marking | Transport Media | NSC Drawing |
|------------|--------|----------------|-----------------|-------------------------|-------------|
| 6-Pin TSOT | 20V/V | LMP8640MK-T | AA6A | 1k Units Tape and Reel | MK06A |
| | | LMP8640MKE-T | | 250 Units Tape and Reel | |
| | | LMP8640MKX-T | | 3k Units Tape and Reel | |
| | | LMP8640HVMK-T | AB6A | 1k Units Tape and Reel | |
| | | LMP8640HVMKE-T | | 250 Units Tape and Reel | |
| | | LMP8640HVMKX-T | | 3k Units Tape and Reel | |
| 6-Pin TSOT | 50V/V | LMP8640MK-F | AC6A | 1k Units Tape and Reel | MK06A |
| | | LMP8640MKE-F | | 250 Units Tape and Reel | |
| | | LMP8640MKX-F | | 3k Units Tape and Reel | |
| | | LMP8640HVMK-F | AD6A | 1k Units Tape and Reel | |
| | | LMP8640HVMKE-F | | 250 Units Tape and Reel | |
| | | LMP8640HVMKX-F | | 3k Units Tape and Reel | |
| 6-Pin TSOT | 100V/V | LMP8640MK-H | AE6A | 1k Units Tape and Reel | MK06A |
| | | LMP8640MKE-H | | 250 Units Tape and Reel | |
| | | LMP8640MKX-H | | 3k Units Tape and Reel | |
| | | LMP8640HVMK-H | AF6A | 1k Units Tape and Reel | |
| | | LMP8640HVMKE-H | | 250 Units Tape and Reel | |
| | | LMP8640HVMKX-H | | 3k Units Tape and Reel | |

Typical Performance Characteristics

Unless otherwise specified: $T_A = 25^\circ\text{C}$, $V_S = V^+ - V^-$, $V_{\text{SENSE}} = +\text{IN} - (-\text{IN})$, $R_L = 10\text{ M}\Omega$.

(-IN), $R_L = 10\text{ M}\Omega$.

Supply Current vs. Supply Voltage

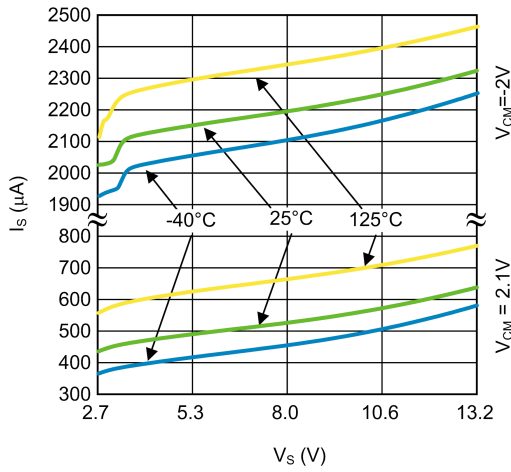

30071425

Supply Current vs. V_{CM}

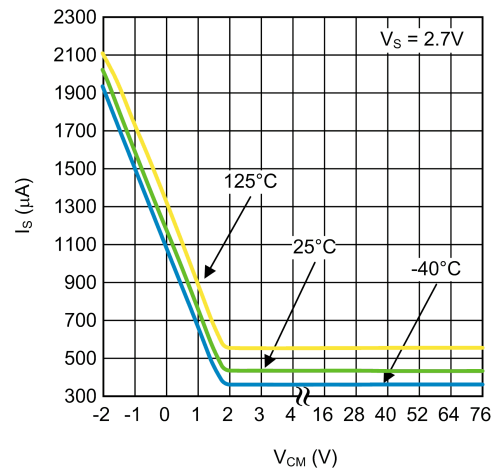

30071426

Supply Current vs. V_{CM}

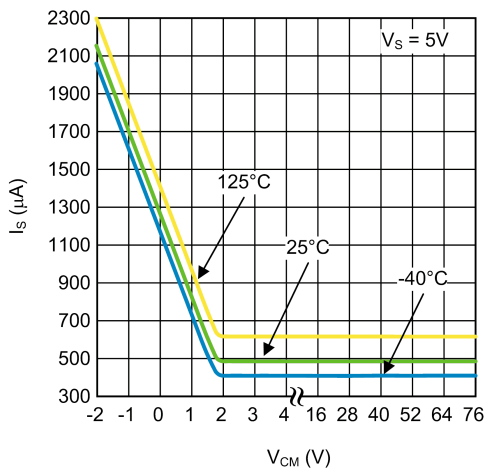

30071427

Supply Current vs. V_{CM}

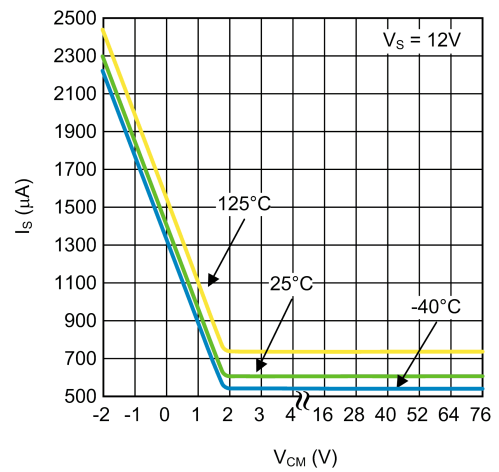

30071428

CMRR vs. V_{CM} (Gain 20V/V)

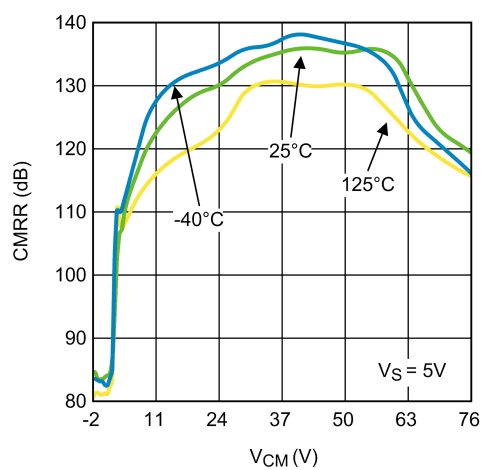

30071422

CMRR vs. V_{CM} (Gain 50V/V)

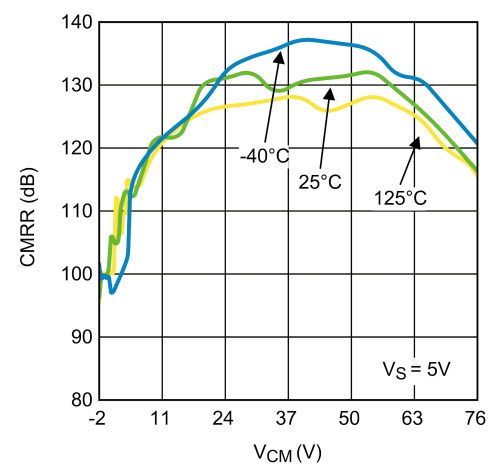

30071423

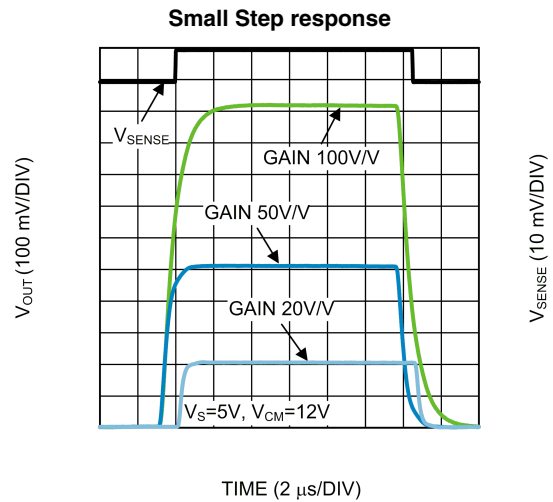
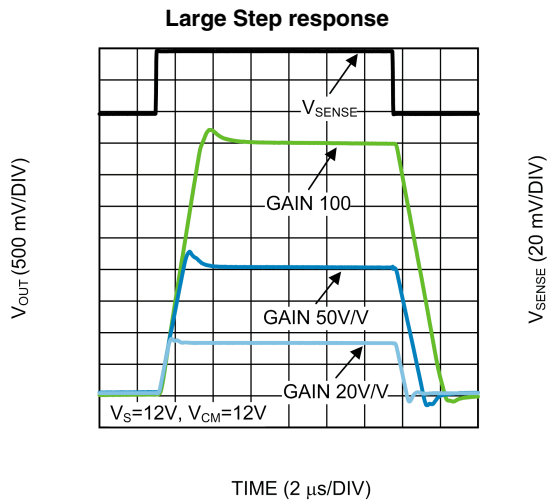
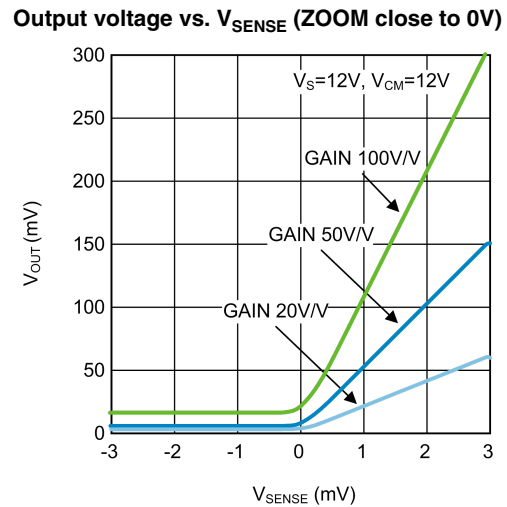
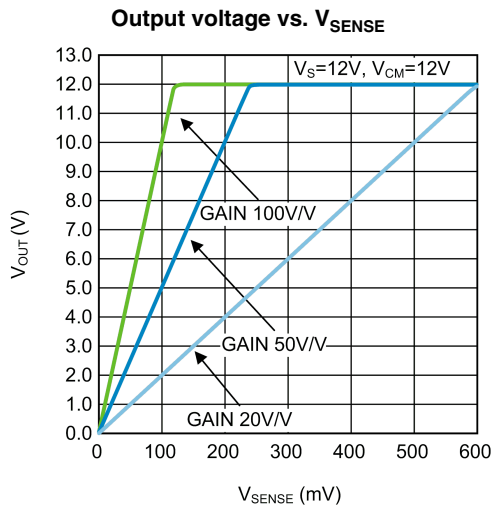
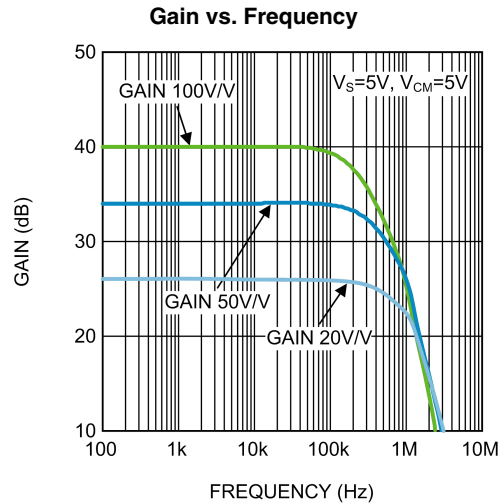
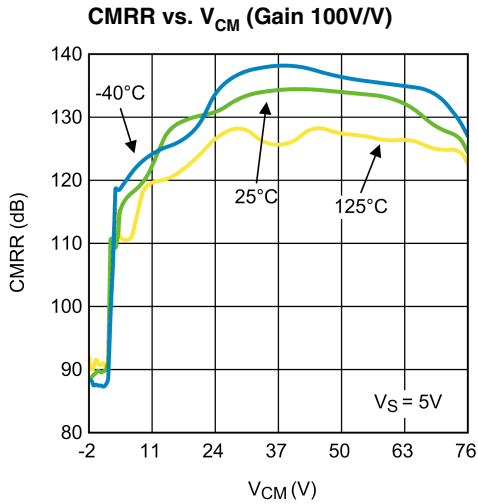

Settling time (fall)

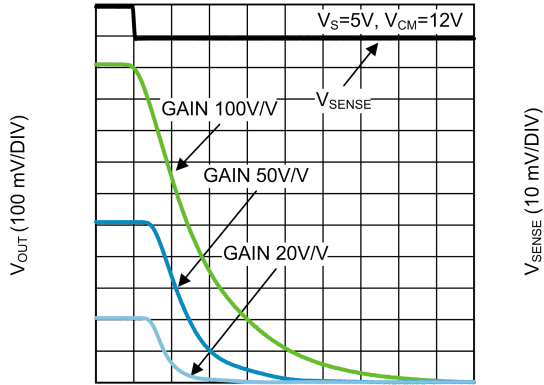

TIME (400 ns/DIV)

30071420

Settling time (rise)

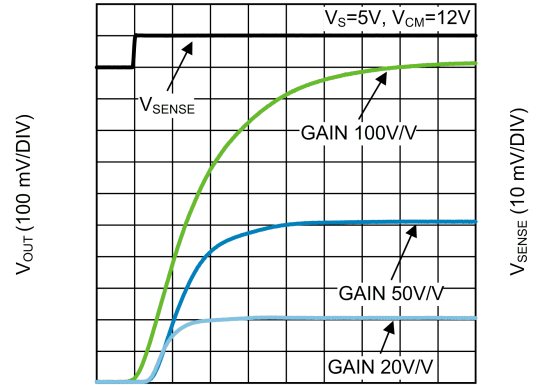

TIME (400 ns/DIV)

30071421

Common mode step response (rise)

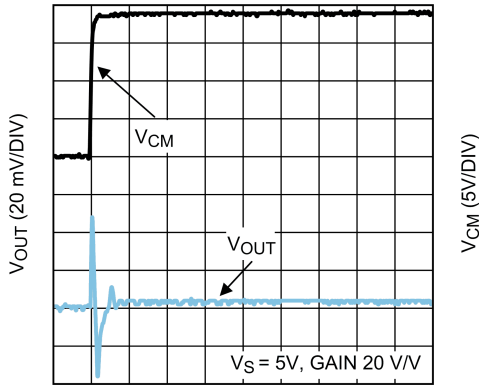

TIME (4 μs/DIV)

30071411

Common mode step response (fall)

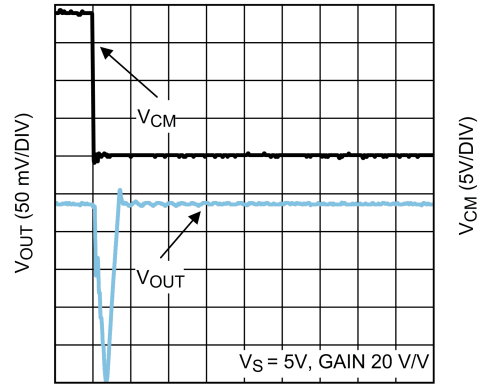

TIME (4 μs/DIV)

30071410

Load regulation (Sinking)

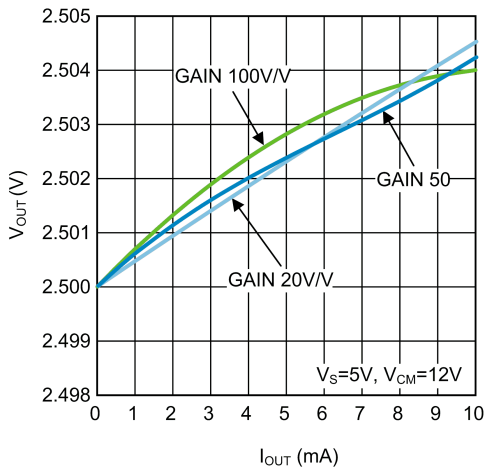

30071432

Load regulation (Sourcing)

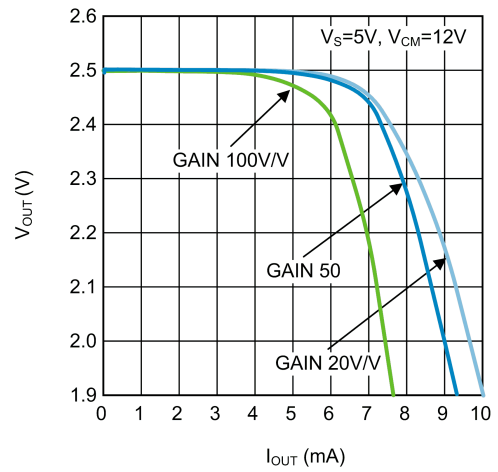

30071431

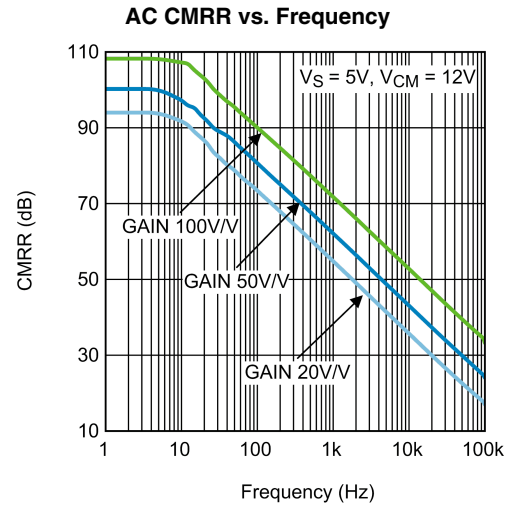
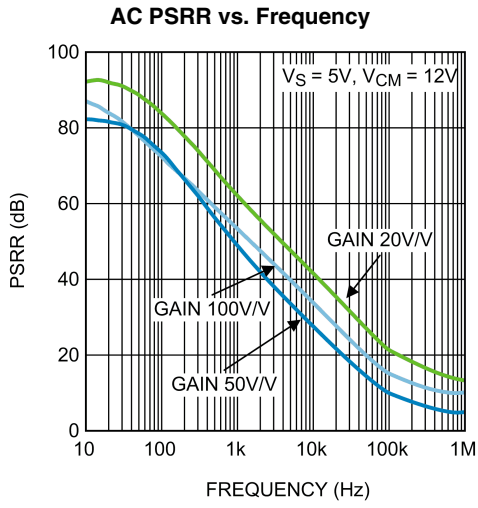

Application Information

GENERAL

The LMP8640 and LMP8640HV are single supply high side current sense amplifiers with a fixed gain of 20V/V, 50V/V, 100V/V and a common mode voltage range of -2V to 42V or -2V to 76V depending on the grade.

THEORY OF OPERATION

As seen from the picture below, the current flowing through R_S develops a voltage drop equal to V_{SENSE} across R_S . The high impedance inputs of the amplifier doesn't conduct this current and the high open loop gain of the sense amplifier forces its non-inverting input to the same voltage as the inverting input. In this way the voltage drop across R_{IN} matches V_{SENSE} . A current proportional to I_S according to the following relation:

$$I_G = V_{SENSE}/R_{IN} = R_S * I_S / R_{IN}$$

flows entirely in the internal gain resistor R_G developing a voltage drop equal to

$$V_{RG} = I_G * R_G = (V_{SENSE}/R_{IN}) * R_G = ((R_S * I_S)/R_{IN}) * R_G$$

This voltage is buffered and showed at the output with a very low impedance allowing a very easy interface of the LMP8640 with other ICs (ADC, $\mu C...$).

$$V_{OUT} = 2 * (R_S * I_S) * G,$$

where $G = R_G/R_{IN} = 10V/V, 25V/V, 50V/V$, according to the gain options.

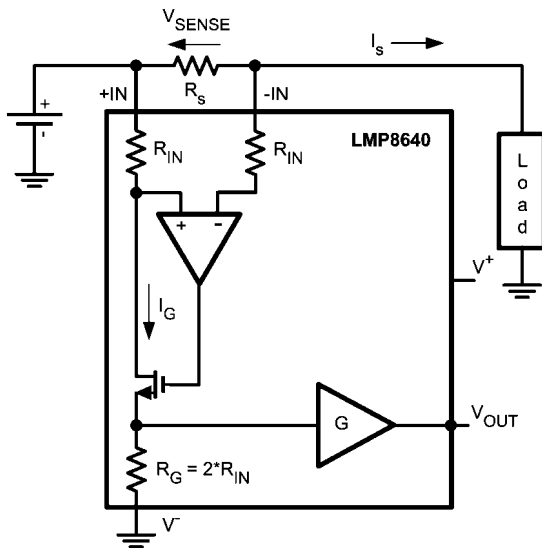

FIGURE 1. Current monitor

SELECTION OF THE SHUNT RESISTOR

The value chosen for the shunt resistor, R_S , depends on the application. It plays a big role in a current sensing system and must be chosen with care. The selection of the shunt resistor needs to take in account the small-signal accuracy, the power dissipated and the voltage loss across the shunt itself. In applications where a small current is sensed, a bigger value of R_S is selected to minimize the error in the proportional output voltage. Higher resistor value improves the SNR at the input of the current sense amplifier and hence gives an accurate output. Similarly when high current is sensed, the power losses in R_S can be significant so a smaller value of R_S is sug-

gested. In this condition is required to take in account also the power rating of R_S resistor. The low input offset of the LMP8640 allows the use of small sense resistors to reduce power dissipation still providing a good input dynamic range. The input dynamic range is the ratio expressed in dB between the maximum signal that can be measured and the minimum signal that can be detected, usually the input offset is the principal limiting factor.

DRIVING ADC

The input stage of an Analog to Digital converter can be modelled with a resistor and a capacitance versus ground. So if the voltage source doesn't have a low impedance an error in the amplitude's measurement will occur. In this case a buffer is needed to drive the ADC. The LMP8640 has an internal output buffer able to drive a capacitance load up to 30 pF or the input stage of an ADC. If required an external low pass RC filter can be added at the output of the LMP8640 to reduce the noise and the bandwidth of the current sense.

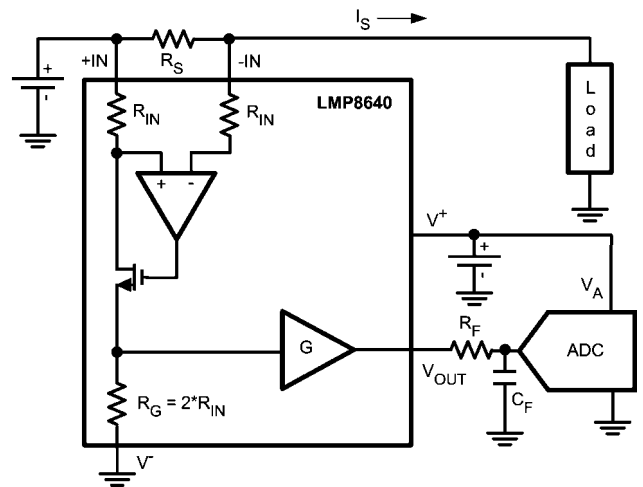

FIGURE 2. LMP8640 to ADC interface

DESIGN EXAMPLE

For example in a current monitor application is required to measure the current sunk by a load (peak current 10A) with a resolution of 10mA and 0.5% of accuracy. The 10bit analog to digital converter accepts a max input voltage of 4.1V. Moreover in order to not burn much power on the shunt resistor it needs to be less than 10m Ω . In the table below are summarized the other working condition.

| Working Condition | Value | |
|---------------------|-------|-------|
| | Min | Max |
| Supply Voltage | 5V | 5.5V |
| Common mode Voltage | 48V | 70V |
| Temperature | 0°C | 70°C |
| Signal BW | | 50kHz |

First step – LMP8640 / LMP8640HV selection

The required common mode voltage of the application implies that the right choice is the LMP8640HV (High common mode voltage up to 76V).

Second step – Gain option selection

We can choose between three gain option (20V/V, 50V/V, 100V/V). considering the max input voltage of the ADC

(4.1V) , the max Sense voltage across the shunt resistor is evaluated according the following formula:

$$V_{\text{SENSE}} = (\text{MAX Vin ADC}) / \text{Gain};$$

hence the max V_{SENSE} will be 205mV, 82mV, 41mV respectively. The shunt resistor are then evaluated considering the maximum monitored current :

$$R_S = (\text{max } V_{\text{SENSE}}) / I_{\text{MAX}}$$

For each gain option the max shunt resistors are the following : 20.5m Ω , 8.2m Ω , 4.1m Ω respectively.

One of the project constraints requires $R_S < 10\text{m}\Omega$, it means that the 20.5m Ω will be discarded and hence the 50V/V and 100V/V gain options are still in play.

Third step – Shunt resistor selection

At this point an error budget calculation, considering the calibration of the Gain, Offset, CMRR, and PSRR, helps in the selection of the shunt resistor. In the table below the contribution of each error source is calculated considering the values of the EC Table at 5V supply.

Resolution Calculation

| ERROR SOURCE | Rs=4.1m Ω | Rs=8.1m Ω |
|---|------------------|------------------|
| CMRR calibrated ad mid VCM range | 77.9 μ V | 77.9 μ V |
| PSRR calibrated at 5V | 8.9 μ V | 8.9 μ V |
| Total error (squared sum of contribution) | 78 μ V | 78 μ V |
| Resolution (Total error / R_S) | 19.2mA | 9.6mA |

Accuracy Calculation

| ERROR SOURCE | Rs=4.1m Ω | Rs=8.1m Ω |
|--|------------------|------------------|
| Tc Vos | 182 μ V | 182 μ V |
| Nosie | 216 μ V | 216 μ V |
| Gain drift | 75.2 μ V | 151 μ V |
| Total error (squared sum of contribution) | 293 μ V | 320 μ V |
| Accuracy 100*(Max_ V_{SENSE} / Total Error) | 0.7% | 0.4% |

From the tables above is clear that the 8.2m Ω shunt resistor allows the respect of the project's constraints. The power burned on the Shunt is 820mW at 10A.

Physical Dimensions inches (millimeters) unless otherwise noted

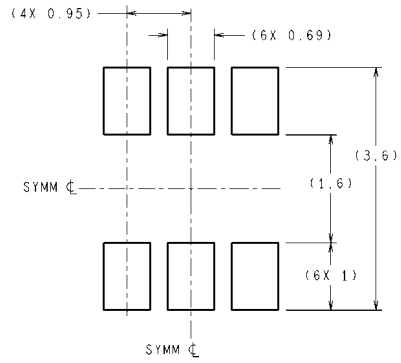
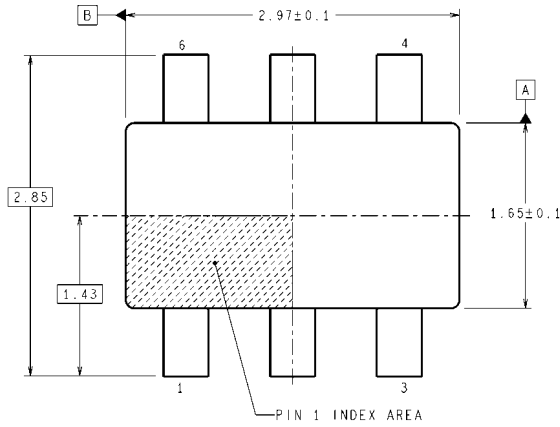

RECOMMENDED LAND PATTERN

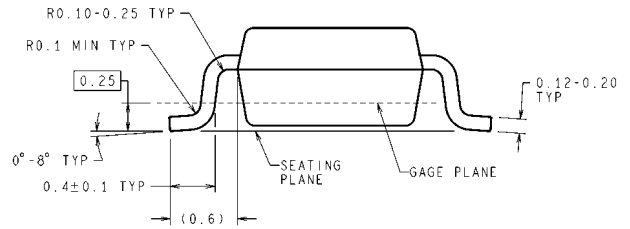
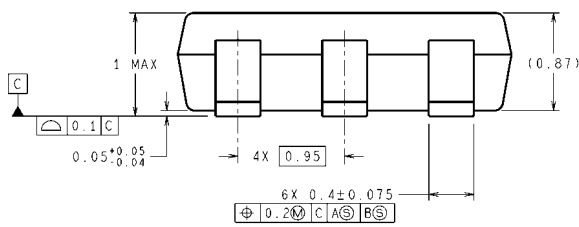

DIMENSIONS ARE IN MILLIMETERS
TSOT-6
NS Package Number MK06A

MK06A (Rev E)

Notes

LMP8640/LMP8640HV

Notes

For more National Semiconductor product information and proven design tools, visit the following Web sites at:
www.national.com

| Products | | Design Support | |
|--------------------------------|--|------------------------------|--|
| Amplifiers | www.national.com/amplifiers | WEBENCH® Tools | www.national.com/webench |
| Audio | www.national.com/audio | App Notes | www.national.com/appnotes |
| Clock and Timing | www.national.com/timing | Reference Designs | www.national.com/refdesigns |
| Data Converters | www.national.com/adc | Samples | www.national.com/samples |
| Interface | www.national.com/interface | Eval Boards | www.national.com/evalboards |
| LVDS | www.national.com/lvds | Packaging | www.national.com/packaging |
| Power Management | www.national.com/power | Green Compliance | www.national.com/quality/green |
| Switching Regulators | www.national.com/switchers | Distributors | www.national.com/contacts |
| LDOs | www.national.com/ldo | Quality and Reliability | www.national.com/quality |
| LED Lighting | www.national.com/led | Feedback/Support | www.national.com/feedback |
| Voltage References | www.national.com/vref | Design Made Easy | www.national.com/easy |
| PowerWise® Solutions | www.national.com/powerwise | Applications & Markets | www.national.com/solutions |
| Serial Digital Interface (SDI) | www.national.com/sdi | Mil/Aero | www.national.com/milaero |
| Temperature Sensors | www.national.com/tempensors | SolarMagic™ | www.national.com/solarmagic |
| PLL/VCO | www.national.com/wireless | PowerWise® Design University | www.national.com/training |

THE CONTENTS OF THIS DOCUMENT ARE PROVIDED IN CONNECTION WITH NATIONAL SEMICONDUCTOR CORPORATION ("NATIONAL") PRODUCTS. NATIONAL MAKES NO REPRESENTATIONS OR WARRANTIES WITH RESPECT TO THE ACCURACY OR COMPLETENESS OF THE CONTENTS OF THIS PUBLICATION AND RESERVES THE RIGHT TO MAKE CHANGES TO SPECIFICATIONS AND PRODUCT DESCRIPTIONS AT ANY TIME WITHOUT NOTICE. NO LICENSE, WHETHER EXPRESS, IMPLIED, ARISING BY ESTOPPEL OR OTHERWISE, TO ANY INTELLECTUAL PROPERTY RIGHTS IS GRANTED BY THIS DOCUMENT.

TESTING AND OTHER QUALITY CONTROLS ARE USED TO THE EXTENT NATIONAL DEEMS NECESSARY TO SUPPORT NATIONAL'S PRODUCT WARRANTY. EXCEPT WHERE MANDATED BY GOVERNMENT REQUIREMENTS, TESTING OF ALL PARAMETERS OF EACH PRODUCT IS NOT NECESSARILY PERFORMED. NATIONAL ASSUMES NO LIABILITY FOR APPLICATIONS ASSISTANCE OR BUYER PRODUCT DESIGN. BUYERS ARE RESPONSIBLE FOR THEIR PRODUCTS AND APPLICATIONS USING NATIONAL COMPONENTS. PRIOR TO USING OR DISTRIBUTING ANY PRODUCTS THAT INCLUDE NATIONAL COMPONENTS, BUYERS SHOULD PROVIDE ADEQUATE DESIGN, TESTING AND OPERATING SAFEGUARDS.

EXCEPT AS PROVIDED IN NATIONAL'S TERMS AND CONDITIONS OF SALE FOR SUCH PRODUCTS, NATIONAL ASSUMES NO LIABILITY WHATSOEVER, AND NATIONAL DISCLAIMS ANY EXPRESS OR IMPLIED WARRANTY RELATING TO THE SALE AND/OR USE OF NATIONAL PRODUCTS INCLUDING LIABILITY OR WARRANTIES RELATING TO FITNESS FOR A PARTICULAR PURPOSE, MERCHANTABILITY, OR INFRINGEMENT OF ANY PATENT, COPYRIGHT OR OTHER INTELLECTUAL PROPERTY RIGHT.

LIFE SUPPORT POLICY

NATIONAL'S PRODUCTS ARE NOT AUTHORIZED FOR USE AS CRITICAL COMPONENTS IN LIFE SUPPORT DEVICES OR SYSTEMS WITHOUT THE EXPRESS PRIOR WRITTEN APPROVAL OF THE CHIEF EXECUTIVE OFFICER AND GENERAL COUNSEL OF NATIONAL SEMICONDUCTOR CORPORATION. As used herein:

Life support devices or systems are devices which (a) are intended for surgical implant into the body, or (b) support or sustain life and whose failure to perform when properly used in accordance with instructions for use provided in the labeling can be reasonably expected to result in a significant injury to the user. A critical component is any component in a life support device or system whose failure to perform can be reasonably expected to cause the failure of the life support device or system or to affect its safety or effectiveness.

National Semiconductor and the National Semiconductor logo are registered trademarks of National Semiconductor Corporation. All other brand or product names may be trademarks or registered trademarks of their respective holders.

Copyright© 2010 National Semiconductor Corporation

For the most current product information visit us at www.national.com



National Semiconductor Americas Technical Support Center
 Email: support@nsc.com
 Tel: 1-800-272-9959

National Semiconductor Europe Technical Support Center
 Email: europe.support@nsc.com

National Semiconductor Asia Pacific Technical Support Center
 Email: ap.support@nsc.com

National Semiconductor Japan Technical Support Center
 Email: jpn.feedback@nsc.com