

GENERAL DESCRIPTION

The XR21V1410 (V1410) is an enhanced Universal Asynchronous Receiver and Transmitter (UART) with a USB interface. The USB interface is fully compliant to Full Speed USB 2.0 specification that supports 12 Mbps USB data transfer rate. The USB interface also supports USB suspend, resume and remote wakeup operations.

The V1410 operates from an internal 48MHz clock therefore no external crystal/oscillator is required like previous generation UARTs. With the fractional baud rate generator, any baud rate can accurately be generated using the internal 48MHz clock.

The large 128-byte TX FIFO and 384-byte RX FIFO of the V1410 helps to optimize the overall data throughput for various applications. The Automatic Transceiver Direction control feature simplifies both the hardware and software for half-duplex RS-485 applications. If required, the multidrop (9-bit) mode with automatic half-duplex transceiver control feature further simplifies typical multidrop RS-485 applications.

The V1410 operates from a single 2.97 to 3.63 volt power supply and has 5V tolerant inputs. The V1410 is available in a 16-pin QFN package.

WHQL certified software drivers for Windows 2000, XP, Vista, 7 and CE, as well as Linux and Mac are supported for the XR21V1410.

APPLICATIONS

- Portable Appliances
- External Converters (dongles)
- Battery-Operated Devices
- Cellular Data Devices
- Factory Automation and Process Controls
- Industrial applications

FEATURES

- USB 2.0 Compliant, Full-Speed (12 Mbps)
 - Supports USB suspend, resume and remote wakeup operations
- Enhanced UART Features
 - Data rates up to 12 Mbps
 - Fractional Baud Rate Generator
 - 128 byte TX FIFO
 - 384 byte RX FIFO
 - 7, 8 or 9 data bits
 - 1 or 2 stop bits
 - Odd, even, mark, space, or no parity
 - Automatic Hardware (RTS/CTS or DTR/DSR) Flow Control
 - Automatic Software (Xon/Xoff) Flow Control
 - Multidrop mode
 - Auto Transceiver Enable
 - Half-Duplex mode
 - Selectable GPIO or Modem I/O
- Internal 48 MHz clock
- Single 2.97-3.63V power supply
- 5V tolerant inputs
- 16-pin QFN package
- Virtual COM Port WHQL certified drivers
 - Windows 2000, XP, Vista and Win7
 - Windows CE 4.2, 5.0, 6.0
 - Linux
 - Mac

FIGURE 1. XR21V1410 BLOCK DIAGRAM

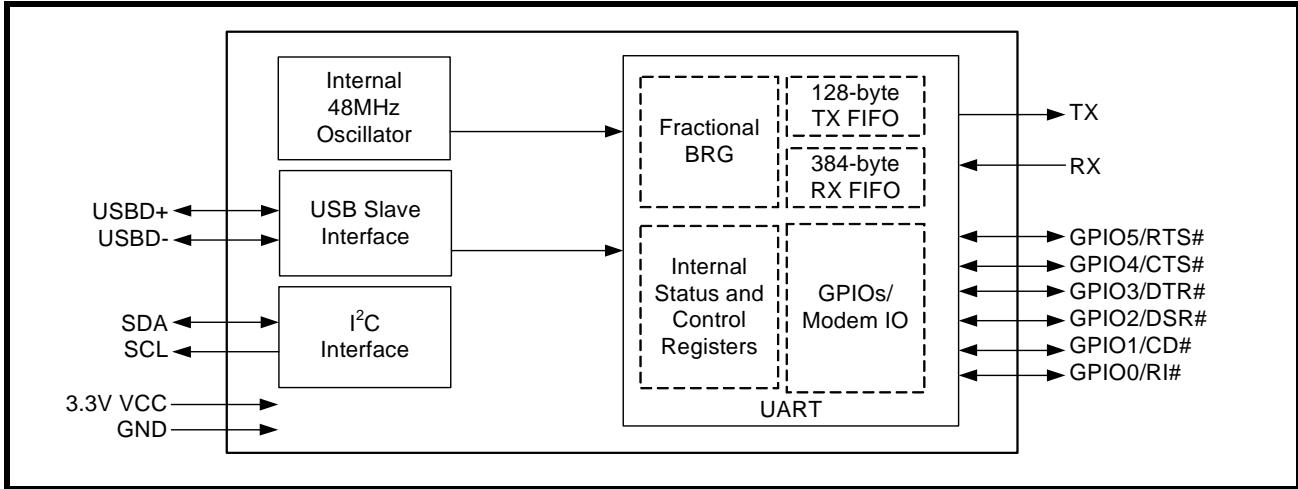
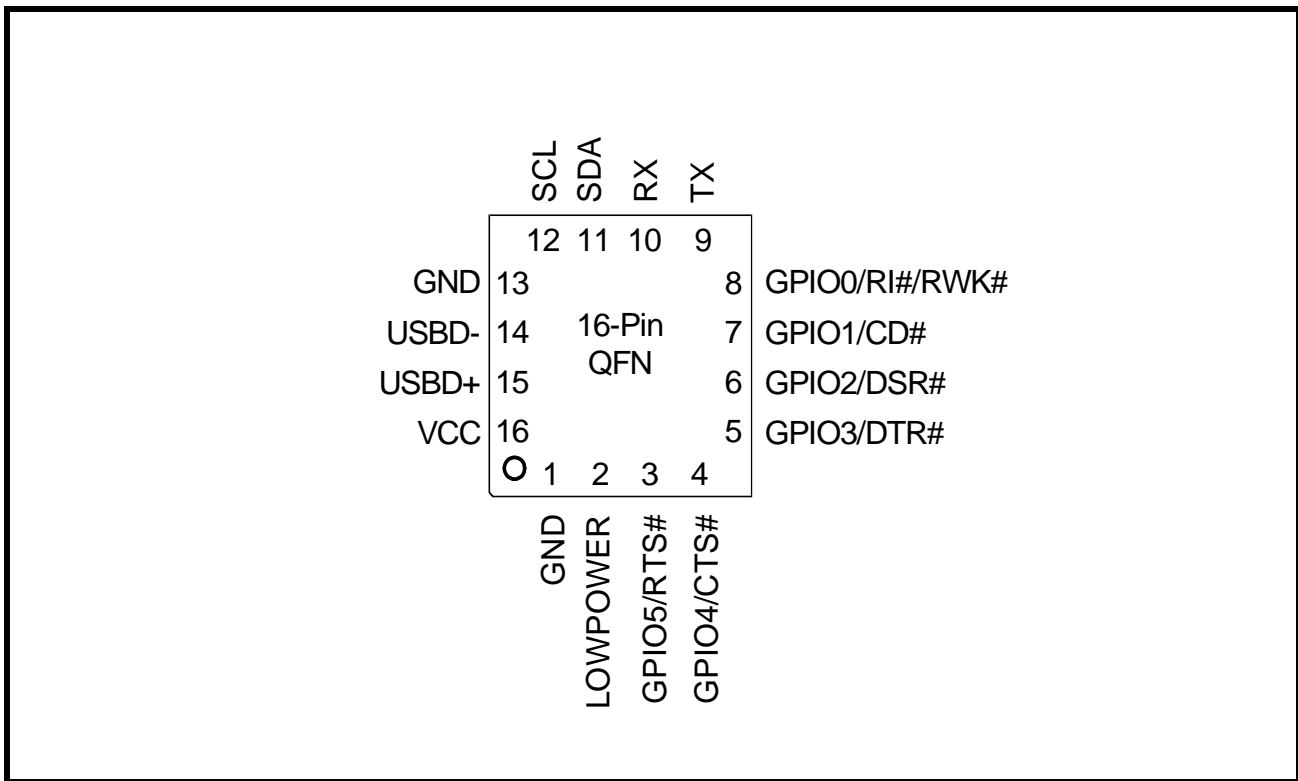

FIGURE 2. PIN OUT ASSIGNMENT



ORDERING INFORMATION

PART NUMBER	PACKAGE	OPERATING TEMPERATURE RANGE	DEVICE STATUS
XR21V1410IL16-F	16-pin QFN	-40°C to +85°C	Active
XR21V1410IL16TR-F	16-pin QFN	-40°C to +85°C	Active

NOTE: TR = Tape and Reel, F = Green / RoHS

PIN DESCRIPTIONS
Pin Description

NAME	16-QFN PIN #	TYPE	DESCRIPTION
UART Signals			
RX	10	I	UART Channel A Receive Data or IR Receive Data. This pin has an internal pull-up resistor. Internal pull-up resistor is <u>not</u> disabled during suspend mode.
TX	9	O	UART Channel A Transmit Data or IR Transmit Data.
GPIO0/RI#/RWK#	8	I/O	General purpose I/O or UART Ring-Indicator input (active low) or Remote Wakeup input. See " Section 1.5.11, Remote Wakeup " on page 10 . This pin has an internal pull-up resistor which is disabled during suspend mode. If using this GPIO as an input, an external pull-up resistor is required to minimize the device power consumption in the suspend mode.
GPIO1/CD#	7	I/O	General purpose I/O or UART Carrier-Detect input (active low). This pin has an internal pull-up resistor which is disabled during suspend mode. If using this GPIO as an input, an external pull-up resistor is required to minimize the device power consumption in the suspend mode.
GPIO2/DSR#	6	I/O	General purpose I/O or UART Data-Set-Ready input (active low). See " Section 1.5.5, Automatic DTR/DSR Hardware Flow Control " on page 9 . This pin has an internal pull-up resistor which is disabled during suspend mode. If using this GPIO as an input, an external pull-up resistor is required to minimize the device power consumption in the suspend mode.
GPIO3/DTR#	5	I/O	General purpose I/O or UART Data-Terminal-Ready output (active low). See " Section 1.5.5, Automatic DTR/DSR Hardware Flow Control " on page 9 . This pin has an internal pull-up resistor which is disabled during suspend mode. If using this GPIO as an input, an external pull-up resistor is required to minimize the device power consumption in the suspend mode.
GPIO4/CTS#	4	I/O	General purpose I/O or UART Clear-to-Send input (active low). See " Section 1.5.4, Automatic RTS/CTS Hardware Flow Control " on page 8 . This pin has an internal pull-up resistor which is disabled during suspend mode. If using this GPIO as an input, an external pull-up resistor is required to minimize the device power consumption in the suspend mode.
GPIO5/RTS#	3	I/O	General purpose I/O or UART Request-to-Send output (active low). See " Section 1.5.4, Automatic RTS/CTS Hardware Flow Control " on page 8 . This pin has an internal pull-up resistor which is disabled during suspend mode. If using this GPIO as an input, an external pull-up resistor is required to minimize the device power consumption in the suspend mode.

Pin Description

NAME	16-QFN PIN #	TYPE	DESCRIPTION
USB Interface Signals			
USBD+	15	I/O	USB port differential data plus. This pin has a 1.5 K Ohm internal pull-up resistor.
USBD-	14	I/O	USB port differential data minus.
I²C Interface Signals			
SDA	11	I/O OD	I ² C-controller data input/output (open-drain). An optional external I ² C EEPROM can be used to store default configurations upon power-up including the USB Vendor ID and Device ID. See Table 3 . A pull-up resistor (typically 4.7 to 10 KOhms) is required. If an EEPROM is not used, this pin can be used with the SCL pin to select the Remote Wake-up and Power modes. An external pull-up or pull-down resistor is required. See Table 2
SCL	12	OD	I ² C-controller serial input clock. An optional external I ² C EEPROM can be used to store default configurations upon power-up including the USB Vendor ID and Device ID. See Table 3 . A pull-up resistor (typically 4.7 to 10 KOhms) is required. If an EEPROM is not used, this pin can be used with the SDA pin to select the Remote Wake-up and Power modes. An external pull-up or pull-down resistor is required. See Table 2
Miscellaneous Signals			
LOWPOWER	2	O	Low power status output. This pin will be asserted whenever the V1410 device is placed into the suspend state. This pin is sampled momentarily at power-up or at any USB bus reset to configure the polarity of the LOWPOWER output during suspend mode. An external (10K) pull-up resistor will cause the LOWPOWER pin to be asserted HIGH during suspend mode. An external (3.3K) pull-down resistor will cause the LOWPOWER pin to be asserted LOW during suspend mode.
VCC	16	Pwr	+3.3V power supply. (Note that all device inputs are 5V tolerant.)
GND	1, 13	Pwr	Power supply common, ground.

NOTE: Pin type: I=Input, O=Output, I/O= Input/output, OD=Output Open Drain.

1.0 FUNCTIONAL DESCRIPTIONS

1.1 USB interface

The USB interface of the V1410 is compliant with the USB 2.0 Full-Speed Specifications. The USB configuration model presented by the V1410 to the device driver is compatible to the Abstract Control Model of the USB Communication Device Class (CDC-ACM). The V1410 uses the following set of parameters:

- 1 Control Endpoint
 - Endpoint 0 as outlined in the USB specifications
- 1 Configuration is supported
- 2 interfaces for the UART channel
 - Single interrupt endpoint
 - Bulk-in and bulk-out endpoints

1.1.1 USB Vendor ID

Exar's USB Vendor ID is 0x04E2. This is the default Vendor ID that is used for the V1410 unless a valid EEPROM is present on the I²C interface signals. If a valid EEPROM is present, the Vendor ID from the EEPROM will be used.

1.1.2 USB Product ID

The default USB Product ID for the V1410 is 0x1410. If a valid EEPROM is present, the Product ID from the EEPROM will be used.

1.2 USB Device Driver

The V1410 device can be used with either a standard CDC-ACM driver or a custom driver. When the CDC-ACM driver is used, the driver has no knowledge of the V1410 device registers. Because of this, the V1410 device is initialized to the following settings:

TABLE 1: V1410 REGISTER DEFAULTS WITH CDC-ACM DRIVER

REGISTER	VALUE	NOTES
FLOW_CONTROL	0x01	Hardware flow control
GPIO_MODE	0x01	RTS / CTS flow control
GPIO_DIRECTION	0x08	DTR configured as an output (in addition to RTS which is set by GPIO_MODE)
GPIO_INT_MASK	0x30	CD and DSR are interrupt sensitive, i.e. can cause a USB interrupt to be generated

1.3 I²C Interface

The I²C interface provides connectivity to an external I²C memory device (i.e. EEPROM) that can be read by the V1410 for configuration.

The SDA and SCL are used to specify whether Remote Wakeup and/or Bus Powered configurations are to be supported. These pins are sampled at power-up. The following table describes how Remote Wakeup and Bus Powered support.

TABLE 2: REMOTE WAKEUP AND POWER MODES

SDA	SCL	REMOTE WAKE-UP SUPPORT	POWER MODE
1	1	No	Self-Powered
1	0	No	Bus-Powered
0	1	Yes	Self-Powered
0	0	Yes	Bus-Powered

1.3.1 EEPROM Contents

The I²C address should be 0xA0. An EEPROM can be used to override default Vendor IDs and Device IDs, as well as other attributes and maximum power consumption. The EEPROM must contain 8 bytes of data as specified in [Table 3](#)

TABLE 3: EEPROM CONTENTS

EEPROM ADDRESS	CONTENTS
0	Vendor ID (LSB)
1	Vendor ID (MSB)
2	Product ID (LSB)
3	Product ID (MSB)
4	Device Attributes
5	Device Maximum Power
6	Reserved
7	Signature of 0x58 ('X'). If the signature is not correct, the contents of the EEPROM are ignored.

These values are uploaded from the EEPROM to the corresponding USB Standard Device Descriptor or Standard Configuration Descriptor. For details of the USB Descriptors, refer to the USB 2.0 specifications.

1.3.1.1 Vendor ID

The Vendor ID value replaces the idVendor field in the USB Standard Device Descriptor.

1.3.1.2 Product ID

The Product ID value replaces the idProduct field in the USB Standard Device Descriptor.

1.3.1.3 Device Attributes

The Device Attributes value replaces the bmAttributes field in the USB Standard Configuration Descriptor. The default setting in the V1410 device is 0xA0. The bit field definitions are:

- Bit 7 is reserved - set to '1'

- Bit 6 is Self-powered mode - set to '0' for bus-powered, set to '1' for self-powered
- Bit 5 is Remote Wakeup support - set to '0' for no support, set to '1' for remote wakeup support
- Bit 4:0 are reserved - set to '0'

1.3.1.4 Device Maximum Power

The Device Maximum Power value replaces the bMaxPower field in the USB Standard Configuration Descriptor. The value specified is in units of 2 mA. For example, the value 0x2F is decimal 47 or 94 mA. Note that the default bMaxPower of the V1410 device is 94 mA.

1.4 UART Manager

The UART Manager enables/disables the UART including the TX and RX FIFOs. The UART Manager is located in a separate register block from the UART registers.

1.5 UART

The UART can be configured via USB control transfers from the USB host. The UART transmitter and receiver sections are described separately in the following sections. At power-up, the V1410 will default to 9600 bps, 8 data bits, no parity bit, 1 stop bit, and no flow control. If a standard CDC driver accesses the V1410, defaults will change. **See "Section 1.2, USB Device Driver" on page 5.**

1.5.1 Transmitter

The transmitter consists of a 128-byte TX FIFO and a Transmit Shift Register (TSR). Once a bulk-out packet has been received and the CRC has been validated, the data bytes in that packet are written into the TX FIFO of the specified UART channel. Data from the TX FIFO is transferred to the TSR when the TSR is idle or has completed sending the previous data byte. The TSR shifts the data out onto the TX output pin at the data rate defined by the CLOCK_DIVISOR and TX_CLOCK_MASK registers. The transmitter sends the start bit followed by the data bits (starting with the LSB), inserts the proper parity-bit if enabled, and adds the stop-bit(s). The transmitter can be configured for 7 or 8 data bits with or without parity or 9 data bits without parity. If 9 bit data is selected without wide mode, the 9th bit will always be '0'.

1.5.1.1 Wide Mode Transmit

When both 9 bit data and wide mode are enabled, two bytes of data must be written. The first byte that is loaded into the TX FIFO are the first 8 bits (data bits 7-0) of the 9-bit data. Bit-0 of the second byte that is loaded into the TX FIFO is bit-8 of the 9-bit data. The data that is transmitted on the TX pin is as follows: start bit, 9-bit data, stop bit. Use the WIDE_MODE register to enable wide mode.

1.5.2 Receiver

The receiver consists of a 384-byte RX FIFO and a Receive Shift Register (RSR). Data that is received in the RSR via the RX pin is transferred into the RX FIFO along with any error tags such as Framing, Parity, Break and Overrun errors. Data from the RX FIFO can be sent to the USB host by sending a bulk-in packet.

If the wide mode is not enabled, then 7 or 8 bits of data and optionally a parity bit are transferred to the USB host

1.5.2.1 Wide mode Receive

In wide mode, the V1410 receives a 7, 8 or 9 bit character and then forwards the character along with 3 associated error bits to the USB host in two bytes. If data is 7 or 8 bits, a parity bit is also received and checked if enabled. If data is 9 bits, no parity is checked. The 9th bit of data is in bit position 0 along with the 3 error bits, break, frame error and overrun error flags in bit positions 1, 2 & 3 respectively. In wide mode, the parity and framing error and break flag are associated with the character that they accompany and the overrun error is tied to the current contents of the entire RX FIFO.

FIGURE 3. RECEIVE DATA FORMAT

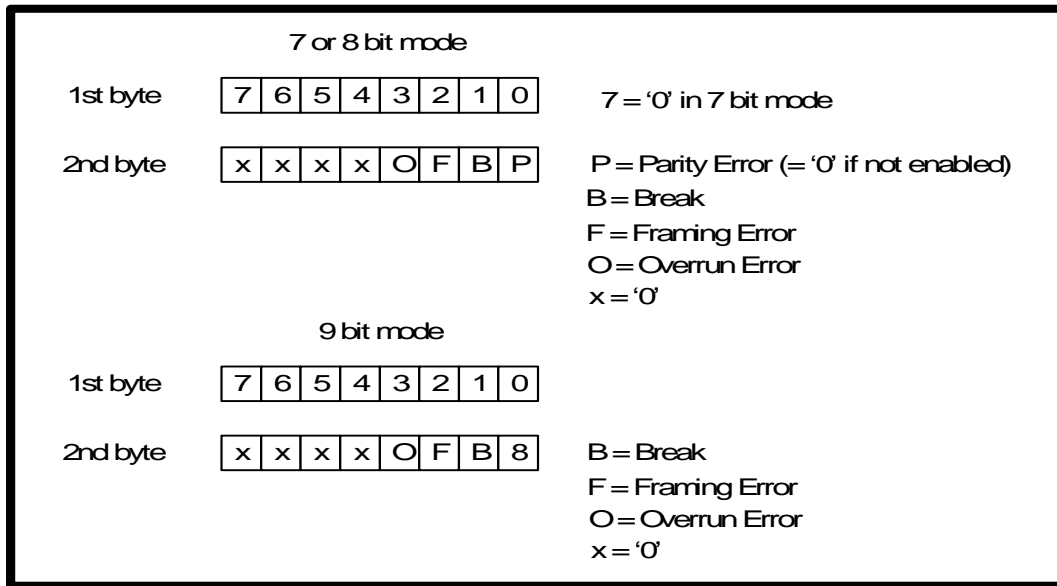

Error flags are also available from the ERROR_STATUS register and the interrupt packet, however these flags are historical flags indicating that an error has occurred since the previous read of the status register. Therefore, no conclusion can be drawn as to which specific byte(s) may have contained an actual error in this manner.

1.5.3 GPIO

There are 6 GPIOs. By default, the GPIOs are general purpose I/Os. However, there are few modes that can be enabled to add additional feature such as Auto RTS/CTS Flow control, Auto DTR/DSR Flow Control or Transceiver Enable Control. See [Table 14](#).

1.5.4 Automatic RTS/CTS Hardware Flow Control

GPIO5 and GPIO4 of the UART channel can be enabled as the RTS# and CTS# signals for Auto RTS/CTS flow control when GPIO_MODE[2:0] = '001' and FLOW_CONTROL[2:0] = '001'. Automatic RTS flow control is used to prevent data overrun errors in local RX FIFO by de-asserting the RTS signal to the remote UART. When there is room in the RX FIFO, the RTS pin will be re-asserted. Automatic CTS flow control is used to prevent data overrun to the remote RX FIFO. The CTS# input is monitored to suspend/restart the local transmitter (see [Figure 4](#)):

FIGURE 4. AUTO RTS AND CTS FLOW CONTROL OPERATION

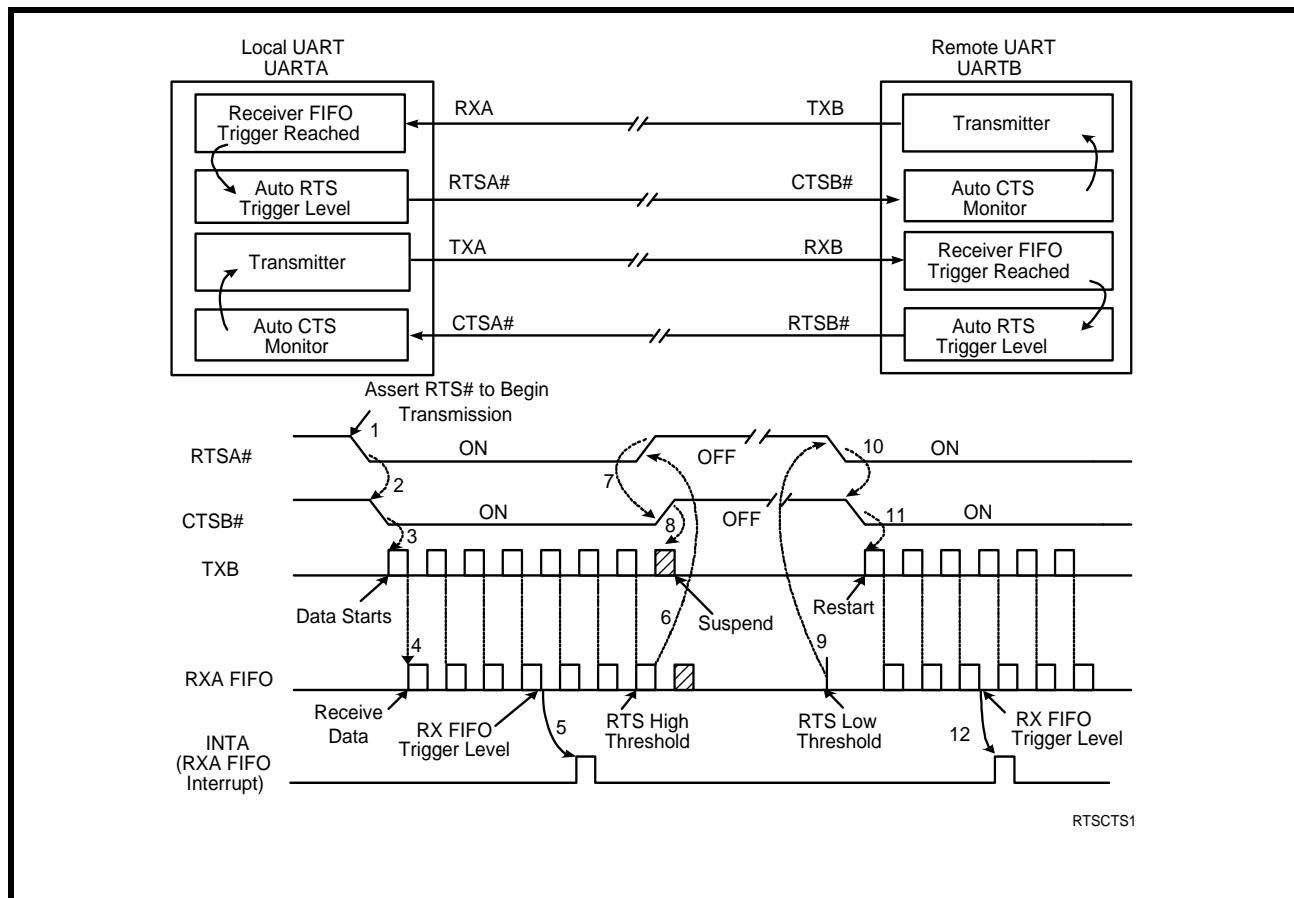

1.5.5 Automatic DTR/DSR Hardware Flow Control

Auto DTR/DSR hardware flow control behaves the same as the Auto RTS/CTS hardware flow control described above except that it uses the DTR# and DSR# signals. For Auto hardware flow control, `FLOW_CONTROL[2:0] = '001'`. GPIO3 and GPIO2 become DTR# and DSR#, respectively, when `GPIO_MODE[2:0] = '010'`.

1.5.6 Automatic XON/XOFF Software Flow Control

When software flow control is enabled, the V1410 compares the receive data characters with the programmed Xon or Xoff characters. If the received character matches the programmed Xoff character, the V1410 will halt transmission as soon as the current character has completed transmission. Data transmission is resumed when a received character matches the Xon character. Software flow control is enabled when `FLOW_CONTROL[2:0] = '010'`.

1.5.7 Multidrop Mode with address matching

The V1410 device has two address matching modes which are also set by the flow control register using modes 3 and 4. These modes are intended for a multi-drop network application. In these modes, the XON_CHAR register holds a unicast address and the XOFF_CHAR holds a multicast address. A unicast address is used by a transmitting master to broadcast an address to all attached slave devices that is intended for only one slave device. A multicast address is used to broadcast an address intended for more than one recipient device. Each attached slave device should have a unique unicast address value stored in the XON_CHAR register, while multiple slaves may have the same multicast address stored in the XOFF_CHAR register. An address match occurs when an address byte (9th bit or parity bit is '1') is received that matches the value stored in either the XON_CHAR or XOFF_CHAR register.

1.5.7.1 Receiver

If an address match occurs in either flow control mode 3 or 4, the address byte will not be loaded into the RX FIFO, but all subsequent data bytes will be loaded into the RX FIFO. The UART Receiver will automatically be disabled when an address byte is received that does not match the values in the XON_CHAR or XOFF_CHAR register.

1.5.7.2 Transmitter

In flow control mode 3, the UART transmitter is always enabled, irrespective of the Rx address match. In flow control mode 4, the UART transmitter will only be enabled if there is an Rx address match.

1.5.8 Programmable Turn-Around Delay

By default, the GPIO5/RTS# pin will be de-asserted immediately after the stop bit of the last byte has been shifted. However, this may not be ideal for systems where the signal needs to propagate over long cables. Therefore, the de-assertion of GPIO5/RTS# pin can be delayed from 1 to 15 bit times via the XCVR_EN_DELAY register to allow for the data to reach distant UARTs.

1.5.9 Half-Duplex Mode

Half-duplex mode is enabled when FLOW_CONTROL[3] = 1. In this mode, the UART will ignore any data on the RX input when the UART is transmitting data.

1.5.10 RX FIFO Latency

In normal operation all bulk-in transfers will be of maxPacketSize (64) bytes to improve throughput and to minimize USB host processing. However, in cases where the baud rate is low this may increase latency unacceptably. To compensate, the V1410 device has a low latency mode in which received data bytes will be immediately forwarded at the next BULK_IN packet. The Low Latency mode will be automatically set from a CDC_ACM_IF_SET_LINE_CODING command whenever the baud rate is less than 46921 bps or alternately a custom driver may set the RX_FIFO_LOW_LATENCY register bit to force RX data to be delivered without delay.

1.5.11 Remote Wakeup

Per USB standard, the V1410 device will begin to enter the Suspend state if it does not detect any activity (including SOF packets) on its USB data lines for 3 ms. The GPIO0/RI#/RWK# pin can be used to request that the host exit the Suspend state. A high to low transition on this pin will cause the device to signal a remote wakeup request to the host via a custom driver. Note that the standard CDC-ACM driver does not support this feature. In order for the remote wakeup to work, several things must be properly configured. First, the GPIO0/RI#/RWK# pin must be configured as an input. Additionally, the V1410 device must have the remote wakeup feature support indicated in the USB attributes - See **“Section 1.3, I2C Interface” on page 6**. Lastly, a custom software driver must inform the USB host that the peripheral device supports the remote wake-up feature.

2.0 USB CONTROL COMMANDS

The following table shows all of the USB Control Commands that are supported by the V1410. Commands included are standard USB commands, CDC-ACM commands and custom Exar commands.

TABLE 4: SUPPORTED USB CONTROL COMMANDS

NAME	REQUEST TYPE	REQUEST	VALUE	INDEX	LENGTH	DESCRIPTION
DEV GET_STATUS	0x80	0	0 0	0 0	2 0	Device: remote wake-up + self-powered
IF GET_STATUS	0x81	0	0 0	1-4, 129-132	2 0	Interface: zero
EP GET_STATUS	0x82	0	0 0	0-4, 129-136	2 0	Endpoint: halted
DEV CLEAR_FEATURE	0x00	1	1 0	0 0	0 0	Device remote wake-up
EP CLEAR_FEATURE	0x02	1	0 0	0-4, 129-136	0 0	Endpoint halt
DEV SET_FEATURE	0x00	3	1 00	0 0	0 0	Device remote wake-up
DEV SET_FEATURE	0x00	3	2 0	0 0	test 0 0	Test mode
EP SET_FEATURE	0x02	3	0 0	0-4, 129-136	0 0	Endpoint halt
SET_ADDRESS	0x00	5	addr 0	0 0	0 0	
GET_DESCRIPTOR	0x80	6	0 1	0 0	len LSB len MSB	Device descriptor
GET_DESCRIPTOR	0x80	6	0 2	0 0	len LSB len MSB	Configuration descriptor
GET_CONFIGURATION	0x80	8	0 0	0 0	1 0	
SET_CONFIGURATION	0x00	9	n 0	0 0	0 0	
GET_INTERFACE	0x81	10	0 0	0-7	0 1 0	
CDC_ACM_IF SET_LINE_CODING	0x21	32	0 0	0, 2, 4, 6	0 7 0	Set the UART baud rate, parity, stop bits, etc.
CDC_ACM_IF GET_LINE_CODING	0xA1	33	0 0	0, 2, 4, 6	0 7 0	Get the UART baud rate, parity, stop bits, etc.
CDC_ACM_IF SET_CONTROL_LINE_STATE	0x21	34	val 0	0, 2, 4, 6	0 0 0	Set UART control lines

TABLE 4: SUPPORTED USB CONTROL COMMANDS

NAME	REQUEST TYPE	REQUEST	VALUE		INDEX		LENGTH		DESCRIPTION
			val LSB	val MSB	0, 2, 4, 6	0	0	0	
CDC_ACM_IF SEND_BREAK	0x21	35	val LSB	val MSB	0, 2, 4, 6	0	0	0	Send a break for the specified duration
XR_SET_REG	0x40	0	val	0	register	block	0	0	Exar custom command: set one 8-bit register val: 8-bit register value register address: see Table 7 block number: see Table 5
XR_GETN_REG	0xC0	1	0	0	register	block	count LSB	count MSB	Exar custom register: get count 8-bit registers register address: see Table 7 block number: see Table 5

2.1 UART Block Numbers

The table below lists the block numbers for accessing each of the UART channels and the UART Manager..

TABLE 5: CONTROL BLOCKS

BLOCK NAME	BLOCK NUMBER	DESCRIPTION
UART	0	The configuration and control registers for the UART.
UART Manager	4	The control registers for the UART Manager. The UART Manager enables/disables the TX and RX FIFOs for each UART.
UART Custom	0x66	Custom UART control registers. Enables / disables for wide mode, low latency mode and custom interrupt packet.

3.0 REGISTER SET DESCRIPTION

The internal register set of the V1410 consists of 3 different blocks of registers: the UART Manager, UART registers and UART miscellaneous registers. The UART Manager controls the TX and RX enables and FIFOs of all UART channels. The UART registers configure and control the remaining UART channel functionality with the exception of low latency mode, wide mode and custom interrupt packet enables in the UART custom register block.

Registers are accessed only via the USB interface by the XR_SET_REG and XR_GET_REG commands listed in [Table 4](#). The register address offsets are given in [Table 6](#), [Table 7](#) and [Table 15](#), and the register blocks are given in [Table 5](#).

3.1 UART Manager Registers

TABLE 6: UART MANAGER REGISTERS

ADDRESS	REGISTER NAME	BIT-7	BIT-6	BIT-5	BIT-4	BIT-3	BIT-2	BIT-1	BIT-0
0X10	FIFO_ENABLE	0	0	0	0	0	0	RX	TX
0X18	RX_FIFO_RESET	Bit-7	Bit-6	Bit-5	Bit-4	Bit-3	Bit-2	Bit-1	Bit-0
0x1C	TX_FIFO_RESET	Bit-7	Bit-6	Bit-5	Bit-4	Bit-3	Bit-2	Bit-1	Bit-0

3.1.1 FIFO_ENABLE Registers

Enables the RX FIFO and TX FIFOs. For proper functionality, the UART TX and RX must be enabled in the following order:

```
FIFO_ENABLE = 0x1      // Enable TX FIFO
UART_ENABLE = 0x3      // Enable TX and RX
FIFO_ENABLE = 0x3      // Enable RX FIFO
```

3.1.2 RX_FIFO_RESET and TX_FIFO_RESET Registers

Writing a non-zero value to these registers resets the FIFOs.

3.2 UART Register Map

TABLE 7: UART REGISTERS

ADDRESS	REGISTER NAME	BIT-7	BIT-6	BIT-5	BIT-4	BIT-3	BIT-2	BIT-1	BIT-0
0X00	Reserved	0	0	0	0	0	0	0	0
0X01	Reserved	0	0	0	0	0	0	0	0
0X02	Reserved	0	0	0	0	0	0	0	0
0X03	UART_ENABLE	0	0	0	0	0	0	RX	TX
0X04	CLOCK_DIVISOR0	Bit-7	Bit-6	Bit-5	Bit-4	Bit-3	Bit-2	Bit-1	Bit-0
0x05	CLOCK_DIVISOR1	Bit-15	Bit-14	Bit-13	Bit-12	Bit-11	Bit-10	Bit-9	Bit-8
0x06	CLOCK_DIVISOR2	0	0	0	0	0	Bit-18	Bit-17	Bit-16
0x07	TX_CLOCK_MASK0	Bit-7	Bit-6	Bit-5	Bit-4	Bit-3	Bit-2	Bit-1	Bit-0
0x08	TX_CLOCK_MASK1	Bit-15	Bit-14	Bit-13	Bit-12	Bit-11	Bit-10	Bit-9	Bit-8
0x09	RX_CLOCK_MASK0	Bit-7	Bit-6	Bit-5	Bit-4	Bit-3	Bit-2	Bit-1	Bit-0
0x0A	RX_CLOCK_MASK1	Bit-15	Bit-14	Bit-13	Bit-12	Bit-11	Bit-10	Bit-9	Bit-8
0x0B	CHARACTER_FORMAT	Stop	Parity			Data Bits			
0x0C	FLOW_CONTROL	0	0	0	0	Half-Duplex	Flow Control Mode Select		
0x0D	Reserved	0	0	0	0	0	0	0	0
0x0E	Reserved	0	0	0	0	0	0	0	0
0x0F	Reserved	0	0	0	0	0	0	0	0
0x10	XON_CHAR	Bit-7	Bit-6	Bit-5	Bit-4	Bit-3	Bit-2	Bit-1	Bit-0
0x11	XOFF_CHAR	Bit-7	Bit-6	Bit-5	Bit-4	Bit-3	Bit-2	Bit-1	Bit-0
0x12	LOOPBACK_CTL	0	0	0	0	0	En	0	0
0x13	ERROR_STATUS	Break Status	Overrun Error	Parity Error	Framing Error	Break Error	0	0	0
0x14	TX_BREAK	Bit-7	Bit-6	Bit-5	Bit-4	Bit-3	Bit-2	Bit-1	Bit-0
0x15	XCVR_EN_DELAY	0	0	0	0	Delay			
0x16	Reserved	0	0	0	0	0	0	0	0
0x17	Reserved	0	0	0	0	0	0	0	0
0x18	Reserved	0	0	0	0	0	0	0	0
0x19	Reserved	0	0	0	0	0	0	0	0
0x1A	GPIO_MODE	0	0	0	0	XCVR Enable Polarity	Mode Select		
0x1B	GPIO_DIRECTION	0	0	GPIO5	GPIO4	GPIO3	GPIO2	GPIO1	GPIO0
0x1C	GPIO_INT_MASK	0	0	GPIO5	GPIO4	GPIO3	GPIO2	GPIO1	GPIO0
0x1D	GPIO_SET	0	0	GPIO5	GPIO4	GPIO3	GPIO2	GPIO1	GPIO0
0x1E	GPIO_CLEAR	0	0	GPIO5	GPIO4	GPIO3	GPIO2	GPIO1	GPIO0
0x1F	GPIO_STATUS	0	0	GPIO5	GPIO4	GPIO3	GPIO2	GPIO1	GPIO0

3.3 UART Register Descriptions

3.3.1 UART_ENABLE Register Description (Read/Write)

This register enables the UART TX and RX. For proper functionality, the UART TX and RX must be enabled in the following order:

```
FIFO_ENABLE = 0x1      // Enable TX FIFO
UART_ENABLE = 0x3      // Enable TX and RX of that channel
FIFO_ENABLE = 0x3      // Enable RX FIFO
```

UART_ENABLE[0]: Enable UART TX

- Logic 0 = UART TX disabled.
- Logic 1 = UART TX enabled.

UART_ENABLE[1]: Enable UART RX

- Logic 0 = UART RX disabled.
- Logic 1 = UART RX enabled.

UART_ENABLE[7:2]: Reserved

These bits are reserved and should remain '0'.

3.3.2 CLOCK_DIVISOR0, CLOCK_DIVISOR1, CLOCK_DIVISOR2 Register Description (Read/Write)

These registers are used for programming the baud rate. The V1410 uses a 19-bit divisor and 16-bit mask register. Using the internal 48MHz oscillator, the 19-bit divisor is calculated as follows:

$$\text{CLOCK_DIVISOR} = \text{Trunc} (48000000 / \text{Baud Rate})$$

For example, if the the baud rate is 115200bps, then

$$\text{CLOCK_DIVISOR} = \text{Trunc} (48000000 / 115200) = \text{Trunc} (416.66667) = 416$$

CLOCK_DIVISOR0[7:0]: Baud rate clock divisor bits [7:0]

CLOCK_DIVISOR1[7:0]: Baud rate clock divisor bits [15:8]

CLOCK_DIVISOR2[2:0]: Baud rate clock divisor bits [18:16]

CLOCK_DIVISOR2[7:3]: Reserved

These bits are reserved and should remain '0'.

3.3.3 TX_CLOCK_MASK0, TX_CLOCK_MASK1 Register Description (Read/Write)

A look-up table is used for the value of the 16-bit TX Clock mask registers. The index of the look-up table is calculated as follows:

$$\text{index} = \text{Trunc} (((48000000 / \text{Baud Rate}) - \text{CLOCK_DIVISOR}) * 32)$$

For example, if the baud rate is 115200bps, then the index will be:

$$\text{index} = \text{Trunc} (((48000000 / 115200) - 416) * 32) = \text{Trunc} (21.3333) = 21$$

The values for some baud rates to program the TX_CLOCK_MASK registers are listed in [Table 8](#). For baud rates that are not listed, use the index to select TX_CLOCK_MASK register values from [Table 9](#).

3.3.4 RX_CLOCK_MASK0, RX_CLOCK_MASK1 Register Description (Read/Write)

The values for some example baud rates to program the RX_CLOCK_MASK registers are listed in [Table 8](#). For baud rates that are not listed, use the same index calculated for the TX_CLOCK_MASK register to select RX_CLOCK_MASK register values from [Table 9](#).

TABLE 8: CLOCK DIVISOR AND CLOCK MASK VALUES FOR COMMON BAUD RATES

BAUD RATE (BPS)	CLOCK DIVISOR (DECIMAL)	TX CLOCK MASK (HEX)	RX CLOCK MASK (HEX)
1200	40000	0x0000	0x0000
2400	20000	0x0000	0x0000
4800	10000	0x0000	0x0000
9600	5000	0x0000	0x0000
19200	2500	0x0000	0x0000
38400	1250	0x0000	0x0000
57600	833	0x0912	0x0924
115200	416	0x0B6D	0x0B6A
230400	208	0x0912	0x0924
460800	104	0x0208	0x0040
500000	96	0x0000	0x0000
576000	83	0x0912	0x0924
921600	52	0x0040	0x0000
1000000	48	0x0000	0x0000
1152000	41	0x0B6D	0x0DB6
1500000	32	0x0000	0x0000
2000000	24	0x0000	0x0000
2500000	19	0x0104	0x0108
3000000	16	0x0000	0x0000
3125000	15	0x0492	0x0492
3500000	13	0x076D	0x0BB6
4000000	12	0x0000	0x0000
4250000	11	0x0122	0x0224
6250000	7	0x0B6D	0x0DB6
8000000	6	0x0000	0x0000
12000000	4	0x0000	0x0000

For baud rates that are not listed in the table above, use the index value calculated using the formula in **“Section 3.3.3, TX_CLOCK_MASK0, TX_CLOCK_MASK1 Register Description (Read/Write)” on page 15** to determine which TX Clock and RX Clock Mask register values to use from **Table 9**. For the the RX Clock Mask register, there are 2 values listed and would depend on whether the Clock Divisor is even or odd. For even Clock Divisors, use the value from the first column. For odd Clock Divisors, use the value from the last column.

TABLE 9: TX AND RX CLOCK MASK VALUES

INDEX (DECIMAL)	TX CLOCK MASK (HEX)	RX CLOCK MASK (HEX) - EVEN CLOCK DIVISOR	RX CLOCK MASK (HEX) - ODD CLOCK DIVISOR
0	0x0000	0x0000	0x0000
1	0x0000	0x0000	0x0000
2	0x0100	0x0000	0x0100
3	0x0020	0x0400	0x0020
4	0x0010	0x0100	0x0010
5	0x0208	0x0040	0x0208
6	0x0104	0x0820	0x0108
7	0x0844	0x0210	0x0884
8	0x0444	0x0110	0x0444
9	0x0122	0x0888	0x0224
10	0x0912	0x0448	0x0924
11	0x0492	0x0248	0x0492
12	0x0252	0x0928	0x0292
13	0x094A	0x04A4	0x0A52
14	0x052A	0x0AA4	0x054A
15	0x0AAA	0x0954	0x04AA
16	0x0AAA	0x0554	0x0AAA
17	0x0555	0x0AD4	0x05AA
18	0x0B55	0x0AB4	0x055A
19	0x06B5	0x05AC	0x0B56
20	0x05B5	0x0D6C	0x06D6
21	0x0B6D	0x0B6A	0x0DB6
22	0x076D	0x06DA	0x0BB6
23	0x0EDD	0x0DDA	0x076E
24	0x0DDD	0x0BBA	0x0EEE
25	0x07BB	0x0F7A	0x0DDE
26	0x0F7B	0x0EF6	0x07DE
27	0x0DF7	0x0BF6	0x0F7E
28	0x07F7	0x0FEE	0x0EFE
29	0x0FDF	0x0FBE	0x07FE
30	0x0F7F	0x0EFE	0x0FFE
31	0x0FFF	0x0FFE	0x0FFD

3.3.5 CHARACTER_FORMAT Register Description (Read/Write)

This register controls the character format such as the word length (7, 8 or 9), parity (odd, even, forced '0', or forced '1') and number of stop bits (1 or 2).

CHARACTER_FORMAT[3:0]: Data Bits.

TABLE 10: DATA BITS

DATA BITS	CHARACTER_FORMAT[3:0]
7	0111
8	1000
9	1001

All other values for CHARACTER_FORMAT[3:0] are reserved.

CHARACTER_FORMAT[6:4]: Parity Mode Select

These bits select the parity mode. If 9-bit data mode has been selected, then writing to these bits will not have any effect. In other words, there will not be an additional parity bit.

TABLE 11: PARITY SELECTION

BIT-6	BIT-5	BIT-4	PARITY SELECTION
0	0	0	No parity
0	0	1	Odd parity
0	1	0	Even parity
0	1	1	Force parity to mark, "1"
1	0	0	Force parity to space, "0"

CHARACTER_FORMAT[7]: Stop Bit select

This register selects the number of stop bits to add to the transmitted character and how many stop bits to check for in the received character.

TABLE 12: STOP BIT SELECTION

BIT-7	NUMBER OF STOP BITS
0	1 stop bit
2	2 stop bits

3.3.6 FLOW_CONTROL Register Description (Read/Write)

These registers select the flow control mode. These registers should only be written to when the UART is disabled. Writing to the FLOW_CONTROL register when the UART is enabled will result in undefined behavior. Note that the FLOW_CONTROL register settings are used in conjunction with the GPIO_MODE register.

FLOW_CONTROL[2:0]: Flow control mode select
TABLE 13: FLOW CONTROL MODE SELECTION

MODE	BIT-2	BIT-1	BIT-0	MODE DESCRIPTION
0	0	0	0	No flow control, no address matching.
1	0	0	1	HW flow control enabled. Auto RTS/CTS or DTR/DSR must be selected by GPIO_MODE.
2	0	1	0	SW flow control enabled
3	0	1	1	Multidrop mode - RX only after address match, TX independent. (Typically used with GPIO_MODE 3)
4	1	0	0	Multidrop mode - RX / TX only after address match. (Typically used with GPIO_MODE 4)

FLOW_CONTROL[3]: Half-Duplex Mode

- Logic 0 = Normal (full-duplex) mode. The UART can transmit and receive data at the same time.
- Logic 1 = Half-duplex Mode. In half-duplex mode, any data on the RX pin is ignored when the UART is transmitting data.

FLOW_CONTROL[7:4]: Reserved

These bits are reserved and should remain '0'.

3.3.7 XON_CHAR, XOFF_CHAR Register Descriptions (Read/Write)

The XON_CHAR and XOFF_CHAR registers store the XON and XOFF characters, respectively, that are used in the Automatic Software Flow control. If the V1410 is configured in multidrop mode, the XON_CHAR and XOFF_CHAR registers are instead used for address matching.

XON_CHAR[7:0]: XON Character

In Automatic Software Flow control mode, the UART will resume data transmission when the XON character has been received.

For behavior in the Address Match mode, see [“Section 1.5.7, Multidrop Mode with address matching” on page 9.](#)

XOFF_CHAR[7:0]: XOFF Character

In Automatic Software Flow control mode, the UART will suspend data transmission when the XOFF character has been received.

For behavior in the Address Match mode, see [“Section 1.5.7, Multidrop Mode with address matching” on page 9.](#)

3.3.8 LOOPBACK_CTL Register Descriptions (Read/Write)
LOOPBACK_CTL[1:0]: Reserved

These bits are reserved and should remain '0'.

LOOPBACK_CTL[2]: Enable

- Logic 0 = Internal UART (TX to RX) loopback is disabled.
- Logic 1 = Internal UART (TX to RX) loopback is enabled.

LOOPBACK_CTL[7:3]: Reserved

These bits are reserved and should remain '0'.

3.3.9 ERROR_STATUS Register Description - Read-only

This register reports any errors that may have occurred on the line such as break, framing, parity and overrun.

ERROR_STATUS[2:0]: Reserved

These bits are reserved. Any values read from these bits should be ignored.

ERROR_STATUS[3]: Break error

- Logic 0 = No break condition
- Logic 1 = A break condition has been detected (clears after read).

ERROR_STATUS[4]: Framing Error

- Logic 0 = No framing error
- Logic 1 = A framing error has been detected (clears after read). A framing error occurs when a stop bit is not present when it is expected.

ERROR_STATUS[5]: Parity Error

- Logic 0 = No parity error
- Logic 1 = A parity error has been detected (clears after read).

ERROR_STATUS[6]: Overrun Error

- Logic 0 = No overrun error
- Logic 1 = An overrun error has been detected (clears after read). An overrun error occurs when the RX FIFO is full and another byte of data is received.

ERROR_STATUS[7]: Break Status

- Logic 0 = Break condition is no longer present.
- Logic 1 = Break condition is currently being detected.

3.3.10 TX_BREAK Register Description (Read/Write)

Writing a non-zero value to this register causes a break condition to be generated continuously until the register is cleared. If data is being shifted out of the TX pin, the data will be completely shifted out before the break condition is generated.

3.3.11 XCVR_EN_DELAY Register Description (Read/Write)
XCVR_EN_DELAY[3:0]: Turn-around delay

This is the number of bit times to wait before changing the direction of the transceiver from transmit to receive when half-duplex mode is enabled.

XCVR_EN_DELAY[3:0]: Reserved

These bits are reserved and should be '0'.

3.3.12 GPIO_MODE Register Description (Read/Write)
GPIO_MODE[2:0]: GPIO Mode Select

There are 4 modes of operation for the GPIOs. The descriptions can be found in **“Section 1.5, UART” on page 7**.

TABLE 14: GPIO MODES

BITS [2:0]	GPIO0	GPIO1	GPIO2	GPIO3	GPIO4	GPIO5	MODE DESCRIPTION
000	GPIO0	GPIO1	GPIO2	GPIO3	GPIO4	GPIO5	GPIO Mode, All GPIO pins available as GPIO
001	GPIO0	GPIO1	GPIO2	GPIO3	CTS#	RTS#	GPIO4 and GPIO5 used for Auto RTS/CTS HW Flow Control
010	GPIO0	GPIO1	DSR#	DTR#	GPIO4	GPIO5	GPIO2 and GPIO3 used for Auto DTR/DSR HW Flow Control
011	GPIO0	GPIO1	GPIO2	GPIO3	GPIO4	XCVR Enable	GPIO5 used for Auto Transceiver Enable during Transmit
100	GPIO0	GPIO1	GPIO2	GPIO3	GPIO4	XCVR Enable	GPIO5 used for Auto Transceiver Enable after address match (See FLOW_CONTROL mode 4).

GPIO_MODE[3]: Transceiver Enable Polarity

- Logic 0 = GPIO5 Low for TX
- Logic 1 = GPIO5 High for TX

GPIO_MODE[7:4]: Reserved

These register bits are reserved. When writing to these bits, the value should be '0'. When reading from these bits, they are undefined and should be ignored.

3.3.13 GPIO_DIRECTION Register Description (Read/Write)

This register controls the direction of the GPIO if it is not controlled by the GPIO_MODE register.

GPIO_DIRECTION[5:0]: GPIOx Direction

- Logic 0 = GPIOx is an input.
- Logic 1 = GPIOx is an output.

GPIO_DIRECTION[7:6]: Reserved

These register bits are reserved and should be '0'.

3.3.14 GPIO_INT_MASK Register Description (Read/Write)

Enables / disables generation of a USB interrupt packet at the change of state of GPIO pins when they are configured as inputs.

GPIO_INT_MASK[5:0]: GPIOx Interrupt Mask

- Logic 0 = A change on this input causes the device to generate an interrupt packet.
- Logic 1 = A change on this input does not cause the device to generate an interrupt packet.

GPIO_INT_MASK[7:6]: Reserved

These register bits are reserved and should be '0'.

3.3.15 GPIO_SET Register Description (Read/Write)

Writing a '1' in this register drives the GPIO output high. Writing a '0' to a bit has no effect. Bits 7-6 are unused and should be '0'.

3.3.16 GPIO_CLEAR Register Description (Read/Write)

Writing a '1' in this register drives the GPIO output low. Writing a '0' to a bit has no effect. Bits 7-6 are unused and should be '0'.

3.3.17 GPIO_STATUS Register Description (Read-Only)

This register reports the current state of the GPIO pin.

3.4 UART Custom Registers..**TABLE 15: UART CUSTOM REGISTERS**

ADDRESS	REGISTER NAME	BIT-7	BIT-6	BIT-5	BIT-4	BIT-3	BIT-2	BIT-1	BIT-0
0X03	WIDE_MODE	0	0	0	0	0	0	0	EN
0x04	LOW_LATENCY	0	0	0	0	0	0	0	EN
0x06	CUSTOM_INT_PACKET	0	GPIO5	GPIO4	GPIO3	GPIO0	0	GPIO2	GPIO1

3.4.1 WIDE_MODE Register Description (Read/Write)

This register enables the Wide mode functionality for the UART.

WIDE_MODE[0]: Enable wide mode

- Logic 0 = Normal (7, 8 or 9 bit data) mode
- Logic 1 = Wide mode - See “[Section 1.5.1.1, Wide Mode Transmit](#)” on page 7 and “[Section 1.5.2.1, Wide mode Receive](#)” on page 7.

WIDE_MODE[7:1]: Reserved

These bits are reserved and should remain '0'.

3.4.2 LOW_LATENCY Register Description (Read/Write)

This register is automatically set to logic '1' for baud rates below 46921 bps, and can be manually set for baud rates of 46921 bps and higher. This register enables the Low latency feature of the UART. Write to this register following any desired baud rate setting change.

LOW_LATENCY[0]: Enable Low Latency mode

- Logic 0 = Receive data is not forwarded from the Rx FIFO until bMaxPacketSize (64 bytes) or timeout (3 characters) has occurred.
- Logic 1 = All data in the RX FIFO is provided to the USB host at the next BULK IN request irrespective of the number of bytes in the FIFO.

LOW_LATENCY[7:1]: Reserved

These bits are reserved and should remain '0'.

3.4.3 CUSTOM_INT_PACKET (Read/Write)

This register is used to enable / disable GPIO status in the high data byte of the custom interrupt packet. See Table 16, “Interrupt Packet Format,” on page 24 and Table 18, “Data Field of Customized Interrupt Packet - Exar Vendor Specific,” on page 25.

CUSTOM_INT_PACKET[0]: GPIO1

- Logic 0 = Disable GPIO1 status in custom interrupt packet.
- Logic 1 = Enable GPIO1 status in custom interrupt packet.

CUSTOM_INT_PACKET[1]: GPIO2

- Logic 0 = Disable GPIO2 status in custom interrupt packet.
- Logic 1 = Enable GPIO2 status in custom interrupt packet.

CUSTOM_INT_PACKET[2]: Reserved

- This bit is reserved and should remain '0'.

CUSTOM_INT_PACKET[3]: GPIO0

- Logic 0 = Disable GPIO0 status in custom interrupt packet.
- Logic 1 = Enable GPIO0 status in custom interrupt packet.

CUSTOM_INT_PACKET[4]: GPIO3

- Logic 0 = Disable GPIO3 status in custom interrupt packet.
- Logic 1 = Enable GPIO3 status in custom interrupt packet.

CUSTOM_INT_PACKET[5]: GPIO4

- Logic 0 = Disable GPIO4 status in custom interrupt packet.
- Logic 1 = Enable GPIO4 status in custom interrupt packet.

CUSTOM_INT_PACKET[6]: GPIO5

- Logic 0 = Disable GPIO5 status in custom interrupt packet.
- Logic 1 = Enable GPIO5 status in custom interrupt packet.

CUSTOM_INT_PACKET[7]: Reserved

This bit is reserved and should remain '0'.

TABLE 16: INTERRUPT PACKET FORMAT

OFFSET	FIELD	SIZE (BYTES)	VALUE	DESCRIPTION
0	bmRequestType	1	8'b10100001	D7 = Device-to-host direction D6:5 = Class Type D4-0: = Interface Recipient
1	bNotification	1	8'h20	Defined encoding for SERIAL_STATE
2	wValue	2	16'h0000	
4	wIndex	2	16'h0000	D15-8 = Reserved (0) D7-0 = Interface number, 8'h00 for the CDC Command Interface
6	wLength	2	16'h0002	2 bytes of transferred data
8	Data	2	Standard int_status (See Table 17 or Table 18)	D15-7 = Reserved (0) D6 = bOverRun D5 = bParity D4 = bFraming D3 = bRingSignal (RI) D2 = bBreak D1 = bTxCarrier (DSR) D0 = bRxCarrier (CD)

TABLE 17: DATA FIELD OF STANDARD INTERRUPT PACKET

BIT(s)	FIELD	DESCRIPTION
D15..D7		Reserved (0)
D6	bOverRun	Received data has been discarded due to overrun in the device.
D5	bParity	A parity error has occurred.
D4	bFraming	A framing error has occurred.
D3	bRingSignal	State of ring signal detection of the device.
D2	bBreak	State of break detection mechanism of the device.
D1	bTxCarrier	State of transmission carrier. This signal corresponds to V.24 signal 106 and RS-232 signal DSR.
D0	bRxCarrier	State of receiver carrier detection mechanism of device. This signal corresponds to V.24 signal 109 and RS-232 signal DCD.

If the Exar vendor specific packet mapping is enabled then the data field also includes status for all of the UART / GPIO pins as follows:

TABLE 18: DATA FIELD OF CUSTOMIZED INTERRUPT PACKET - EXAR VENDOR SPECIFIC

BIT(s)	FIELD	DESCRIPTION
15	D15	Reserved (0)
14	D14	bGPIO5 (RTS)
13	D13	bGPIO4 (CTS)
12	D12	bGPIO3 (DTR)
11	D11	bGPIO0 (RI)
10	D10	Reserved (0)
9	D9	bGPIO2 (DSR)
8	D8	bGPIO1 (CD)
7	D7	Reserved (0)
6	D6	bOverRun
5	D5	bParity
4	D4	bFraming
3	D3	bRingSignal (RI)
2	D2	bBreak
1	D1	bTxCarrier (DSR)
0	D0	bRxCarrier (CD)

4.0 ELECTRICAL CHARACTERISTICS

DC ELECTRICAL CHARACTERISTICS - POWER CONSUMPTION

UNLESS OTHERWISE NOTED: TA = -40° TO +85°C, VCC IS 2.97 TO 3.63V

SYMBOL	PARAMETER	LIMITS 3.3V			UNITS	CONDITIONS
		MIN	TYP	MAX		
I _{CC}	Power Supply Current		16	20	mA	
I _{Susp}	Suspend mode Current		2	2.15	mA	

DC ELECTRICAL CHARACTERISTICS - UART, LOWPOWER & GPIO PINS

UNLESS OTHERWISE NOTED: TA = -40° TO +85°C, VCC IS 2.97 TO 3.63V

SYMBOL	PARAMETER	LIMITS 3.3V		UNITS	CONDITIONS
		MIN	MAX		
V _{IL}	Input Low Voltage	-0.3	0.8	V	
V _{IH}	Input High Voltage	2.0	5.5	V	
V _{OL}	Output Low Voltage		0.3	V	I _{OL} = 4 mA
V _{OH}	Output High Voltage	2.2		V	I _{OH} = -4 mA
I _{IL}	Input Low Leakage Current		±10	uA	
I _{IH}	Input High Leakage Current		±10	uA	
C _{IN}	Input Pin Capacitance		5	pF	

DC ELECTRICAL CHARACTERISTICS - USB I/O PINS

UNLESS OTHERWISE NOTED: TA = -40° TO +85°C, VCC IS 2.97 TO 3.63V

SYMBOL	PARAMETER	LIMITS 3.3V		UNITS	CONDITIONS
		MIN	MAX		
V _{IL}	Input Low Voltage	-0.3	0.8	V	
V _{IH}	Input High Voltage	2.0	5.5	V	
V _{OL}	Output Low Voltage	0	0.3	V	External 15 K Ohm to GND on USB D- pin
V _{OH}	Output High Voltage	2.8	3.6	V	External 15 K Ohm to GND on USB D- pin
V _{DrvZ}	Driver Output Impedance	28	44	Ohms	
I _{OSC}	Open short current Current		35	mA	1.5 V on USB D+ and USB D-

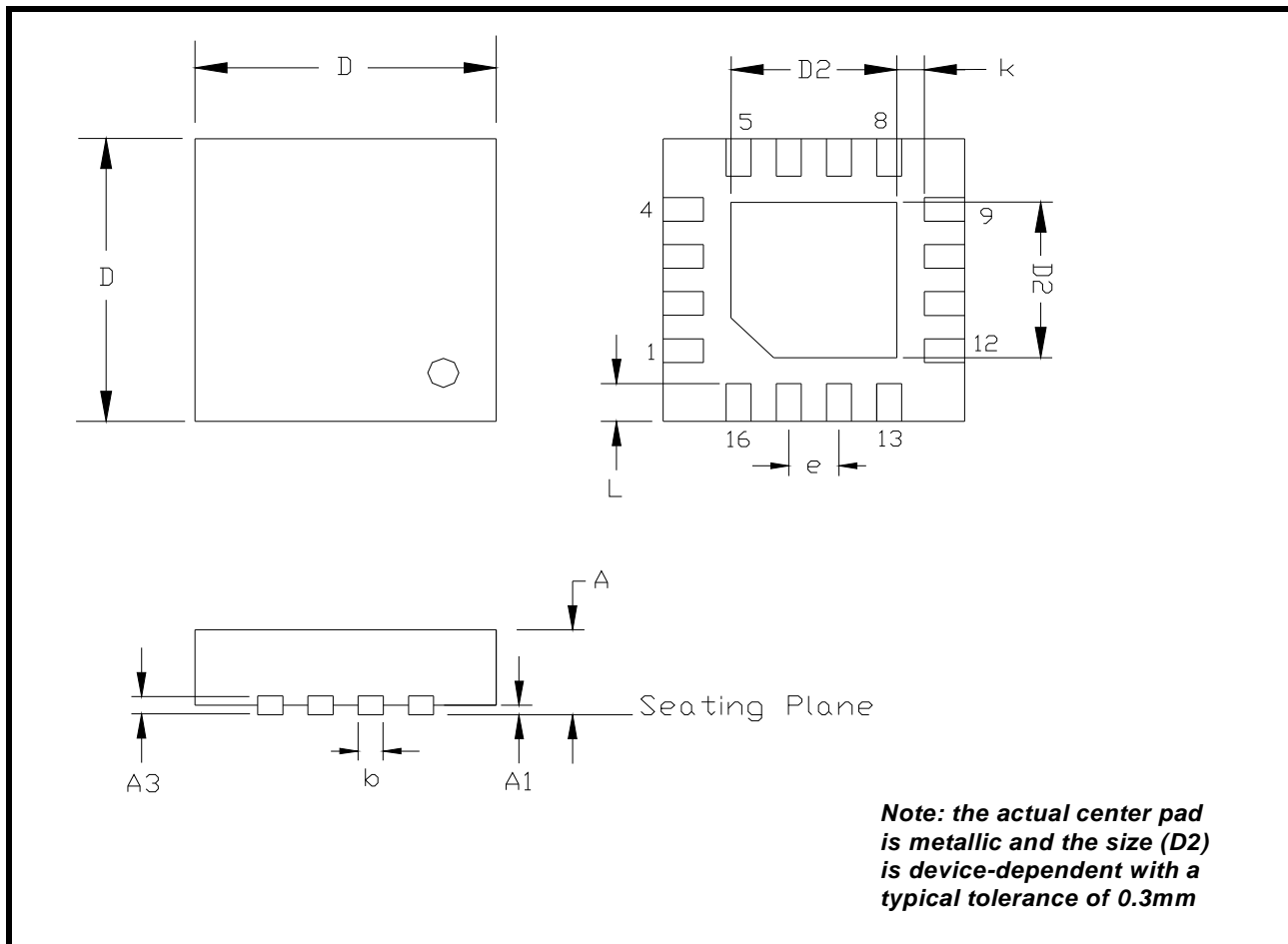
PACKAGE DIMENSIONS (16 PIN QFN - 3 X 3 X 0.9 mm)

Note: The control dimension is the millimeter column

SYMBOL	INCHES		MILLIMETERS	
	MIN	MAX	MIN	MAX
A	0.031	0.035	0.80	0.90
A1	0.000	0.002	0.00	0.05
A3	0.000	0.008	0.00	0.20
D	0.114	0.122	2.90	3.10
D2	0.065	0.069	1.65	1.75
b	0.008	0.012	0.20	0.30
e	0.0197 BSC		0.50 BSC	
L	0.010	0.014	0.25	0.35
k	0.008	-	0.20	-

REVISION HISTORY

DATE	REVISION	DESCRIPTION
June 2009	1.0.0	Released Datasheet
September 2010	1.1.0	Clarified pin functionality, wide mode and low latency mode including registers / blocks, clarified FLOW_CONTROL and GPIO_MODE register functionality.
April 2011	1.2.0	Updated ordering information, SDA/SCL pin types, modified GPIO0 pin name and added LOOPBACK_CTL register and description.

NOTICE

EXAR Corporation reserves the right to make changes to the products contained in this publication in order to improve design, performance or reliability. EXAR Corporation assumes no responsibility for the use of any circuits described herein, conveys no license under any patent or other right, and makes no representation that the circuits are free of patent infringement. Charts and schedules contained here in are only for illustration purposes and may vary depending upon a user's specific application. While the information in this publication has been carefully checked; no responsibility, however, is assumed for inaccuracies.

EXAR Corporation does not recommend the use of any of its products in life support applications where the failure or malfunction of the product can reasonably be expected to cause failure of the life support system or to significantly affect its safety or effectiveness. Products are not authorized for use in such applications unless EXAR Corporation receives, in writing, assurances to its satisfaction that: (a) the risk of injury or damage has been minimized; (b) the user assumes all such risks; (c) potential liability of EXAR Corporation is adequately protected under the circumstances.

Copyright 2009 EXAR Corporation

Datasheet April 2011.

Send your UART technical inquiry with technical details to hotline: uarttechsupport@exar.com.

Reproduction, in part or whole, without the prior written consent of EXAR Corporation is prohibited.