

CKTS	A	B	C
02	.262		.169
	6.65	NA	4.30
04	.380	.118	.287
	9.65	3.00	7.30
06	.498	.236	.405
	12.65	6.00	10.30
08	.616	.354	.524
	15.65	9.00	13.30
10	.734	.472	.642
	18.65	12.00	16.30
12	.852	.591	.760
	21.65	15.00	19.30
14	.970	.709	.878
	24.65	18.00	22.30
16	1.088	.827	.996
	27.65	21.00	25.30
18	1.206	.945	1.114
	30.65	24.00	28.30
20	1.325	1.063	1.232
	33.65	27.00	31.30
22	1.443	1.181	1.350
	36.65	30.00	34.30
24	1.561	1.299	1.469
	39.65	33.00	37.30

- NOTES:**
- HOUSING MATERIAL: GLASS FILLED LIQUID CRYSTAL POLYMER, UL94V-0, COLOR: BLACK
TERMINAL MATERIAL: BRASS ALLOY
 - FINISH: A = .000100/(0.00254) MIN. TIN OVER
.000050/(0.00127) MIN. NICKEL PLATE.
B = .000015/(0.00038) MIN. SELECT GOLD IN CONTACT AREA,
.000100/(0.00254) MIN. SELECT MATTE TIN ON SOLDER TAILS,
BOTH OVER .000050/(0.00127) MIN. NICKEL PLATE.
C = .000030/(0.00076) MIN. SELECT GOLD IN CONTACT AREA,
.000100/(0.00254) MIN. SELECT MATTE TIN ON SOLDER TAILS,
BOTH OVER .000050/(0.00127) MIN. NICKEL PLATE.
 - PRODUCT SPECIFICATION: PS-43045
 - TAPE AND REEL PACK: SEE MOLEX DRAWING PK-70873-05**
 - MATES WITH MICRO FIT (3.0) RECEPTACLE SERIES 43025
 - TO MINIMIZE INSERTION FORCE OF MOUNTING CLIPS DURING ROBOTIC PLACEMENT THE HOLE DIAMETER SHOULD BE INCREASED TO .108±.002 / 2.74±0.05 AND THEN EVALUATED PER PLACEMENT EQUIPMENT.
 - THE COPLANARITY DIMENSION IS ESTABLISHED BY PLACING THE ASSEMBLY ON A FLAT SURFACE. THE DISTANCE FROM THAT SURFACE TO THE BOTTOM OF ANY TERMINAL MUST NOT EXCEED .006/0.15
 - CIRCUIT SIZES 2-6: 'D' IS .265/6.74 FOR .010/0.25 STEP.
CIRCUIT SIZES 8-24: 'D' IS .063/1.60 FOR .010/0.25 STEP.
 - TO AVOID INTERFERENCE BETWEEN RECEPTACLE AND PCB, HEADER MUST BE PLACED WITHIN .400/(10.16) MAX. FROM EDGE OF PCB, AS SHOWN IN LOCATION DETAIL.
 - THIS PART CONFORMS TO CLASS B REQUIREMENTS OF COSMETIC SPECIFICATION PS-45499-002.

	FINISH A	FINISH B	FINISH C
CKTS	MATERIAL NO:	MATERIAL NO:	MATERIAL NO:
02	43045-0206	43045-0207	43045-0208
04	43045-0406	43045-0407	43045-0408
06	43045-0606	43045-0607	43045-0608
08	43045-0806	43045-0807	43045-0808
10	43045-1006	43045-1007	43045-1008
12	43045-1206	43045-1207	43045-1208
14	43045-1406	43045-1407	43045-1408
16	43045-1606	43045-1607	43045-1608
18	43045-1806	43045-1807	43045-1808
20	43045-2006	43045-2007	43045-2008
22	43045-2206	43045-2207	43045-2208
24	43045-2406	43045-2407	43045-2408

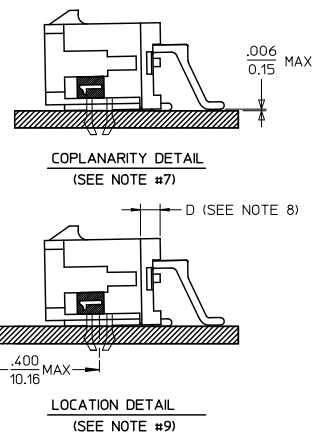

ADD 'D' DIM EC NO. UCP2011-0508 20/08/24 GURUNGHARANI CHKD:SSUSEK 20/08/24 APPR:SMITH 20/10/23	QUALITY SYMBOLS ▽=0 ▽=0 ▽=0	GENERAL TOLERANCES (UNLESS SPECIFIED)	DIMENSION STYLE IN/MM	SCALE ---	DESIGN UNITS METRIC	THIRD ANGLE PROJECTION
		4 PLACES ±.010 ±.010 3 PLACES ±.010 ±.010 2 PLACES ±.025 ±.014 1 PLACE ±0.36 ±.010 ANGULAR ±1/2°	DRAWN BY SAMI EC DATE 2000/03/15	CHECKED BY MUELLER DATE 2000/03/15	APPROVED BY EDGLEY DATE 2000/03/15	TITLE MICRO FIT (3.0) DUAL ROW RIGHT ANGLE SMT HEADER W/CLIPS ASS'Y
DRAFT WHERE APPLICABLE MUST REMAIN WITHIN DIMENSIONS		SEE CHART	THIS DRAWING CONTAINS INFORMATION THAT IS PROPRIETARY TO MOLEX INCORPORATED AND SHOULD NOT BE USED WITHOUT WRITTEN PERMISSION			