

13 12 11 10 9 8 7 6 5 4 3 2 1

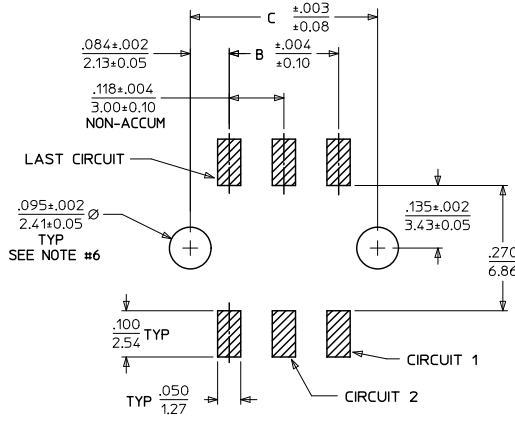

PCB LAYOUT: COMPONENT SIDE
RECOMMENDED PCB THICKNESS: .062/1.57

CKTS	A	B	C
02	.262 6.65	NA	.169 4.30
04	.380 9.65	.118 3.00	.287 7.30
06	.498 12.65	.236 6.00	.405 10.30
08	.616 15.65	.354 9.00	.524 13.30
10	.734 18.65	.472 12.00	.642 16.30
12	.852 21.65	.591 15.00	.760 19.30
14	.970 24.65	.709 18.00	.878 22.30
16	1.088 27.65	.827 21.00	.996 25.30
18	1.206 30.65	.945 24.00	1.114 28.30
20	1.325 33.65	1.063 27.00	1.232 31.30
22	1.443 36.65	1.181 30.00	1.350 34.30
24	1.561 39.65	1.299 33.00	1.469 37.30

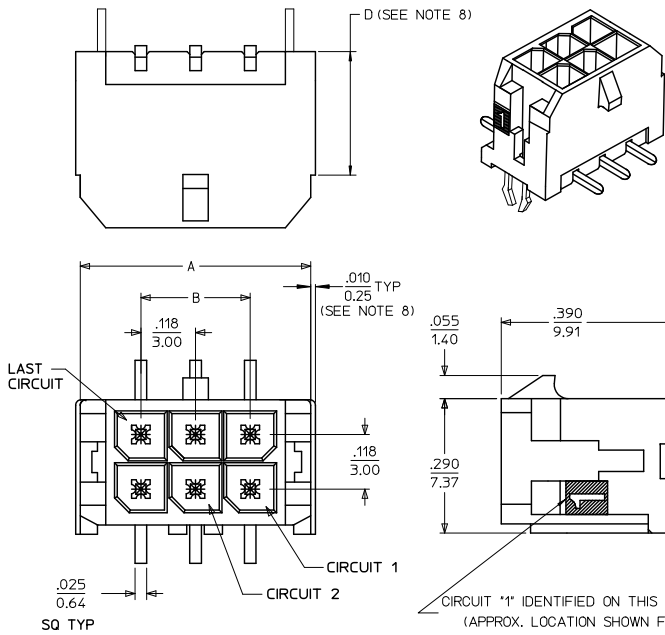
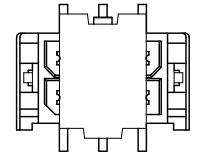
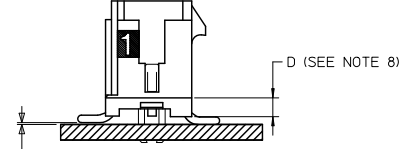

NOTES:

- HOUSING MATERIAL: GLASS FILLED LIQUID CRYSTAL POLYMER, UL94V-0, COLOR: BLACK
TERMINAL MATERIAL: BRASS ALLOY
- FINISH: A = .000100/(0.00254) MIN. TIN OVER
.000050/(0.00127) MIN. NICKEL PLATE.
B = .000015/(0.00038) MIN. SELECT GOLD IN CONTACT AREA,
.000100/(0.00254) MIN. SELECT MATTE TIN ON SOLDER TAILS,
BOTH OVER .000050/(0.00127) MIN. NICKEL PLATE.
C = .000030/(0.00076) MIN. SELECT GOLD IN CONTACT AREA,
.000100/(0.00254) MIN. SELECT MATTE TIN ON SOLDER TAILS,
BOTH OVER .000050/(0.00127) MIN. NICKEL PLATE.
- PRODUCT SPECIFICATION: PS-43045
- TAPE AND REEL PACK : SEE MOLEX DRAWING PK-70873-05**
- MATES WITH MICRO FIT (3.0) RECEPTACLE SERIES 43025
- TO MINIMIZE INSERTION FORCE OF MOUNTING CLIPS DURING ROBOTIC PLACEMENT THE HOLE DIAMETER SHOULD BE INCREASED TO .108±.002 / 2.74±0.05 AND THEN EVALUATED PER PLACEMENT EQUIPMENT.
- THE COPLANARITY DIMENSION IS ESTABLISHED BY PLACING THE ASSEMBLY ON A FLAT SURFACE. THE DISTANCE FROM THAT SURFACE TO THE BOTTOM OF ANY TERMINAL MUST NOT EXCEED .006/0.15
- CIRCUIT SIZES 2-6: 'D' IS 0.265/6.74 FOR .010/0.25 STEP.
CIRCUIT SIZES 8-24: 'D' IS .063/1.60 FOR .010/0.25 STEP.
- THIS PART CONFORMS TO CLASS B REQUIREMENTS OF COSMETIC SPECIFICATION PS-45499-002.

CKTS	FINISH A	FINISH B	FINISH C
	MATERIAL NO.	MATERIAL NO.	MATERIAL NO.
02	43045-0215	43045-0216	43045-0217
04	43045-0415	43045-0416	43045-0417
06	43045-0615	43045-0616	43045-0617
08	43045-0815	43045-0816	43045-0817
10	43045-1015	43045-1016	43045-1017
12	43045-1215	43045-1216	43045-1217
14	43045-1415	43045-1416	43045-1417
16	43045-1615	43045-1616	43045-1617
18	43045-1815	43045-1816	43045-1817
20	43045-2015	43045-2016	43045-2017
22	43045-2215	43045-2216	43045-2217
24	43045-2415	43045-2416	43045-2417

ADD 'D' DIM EC NO. UCP2011-0508 2010/08/26 G. DRWINGIRAMANI 2010/08/24 CHKOSSUSEK 2010/12/23 APPR:SMITH	QUALITY SYMBOLS ∇=0 ∇=0 ∇=0	GENERAL TOLERANCES (UNLESS SPECIFIED): mm INCH		DIMENSION STYLE IN/MM		SCALE ---	DESIGN UNITS METRIC	THIRD ANGLE PROJECTION
		4 PLACES ±--- ±--- 3 PLACES ±--- ±.010 2 PLACES ±0.25 ±.014 1 PLACE ±0.36 ±---	DRAWN BY SAMIEC DATE 2000/03/15	TITLE MICRO FIT (3.0) DUAL ROW VERTICAL SMT HEADER W/CLIPS ASSY				
		ANGULAR ±1/2°	CHECKED BY MUELLER DATE 2000/03/15	MOLEX INCORPORATED				
		DRAFT WHERE APPLICABLE MUST REMAIN WITHIN DIMENSIONS	APPROVED BY EDGLEY DATE 2000/03/15	MATERIAL NO. SEE CHART	DOCUMENT NO. SD-43045-006	SHEET NO. 1 OF 1		

THIS DRAWING CONTAINS INFORMATION THAT IS PROPRIETARY TO MOLEX INCORPORATED AND SHOULD NOT BE USED WITHOUT WRITTEN PERMISSION

12 11 10 9 8 7 6 5 4 3 2 1