

CKT SIZE	PART NUMBER	DIM A	DIM B	DIM C	DIM K	ANTI-WICKING
2	78171-0002	1.2	2.6	4.2	1.5	YES
3	78171-0003	2.4	3.8	5.4	2.7	YES
4	78171-0004	3.6	5.0	6.6	3.9	YES
5	78171-0005	4.8	6.2	7.8	5.1	YES

NOTES:

1. MATERIALS:

HOUSING: LCP, UL94V-0, COLOUR : BLACK
 TERMINAL: COPPER ALLOY
 FITTING NAIL: COPPER ALLOY

2. FINISHES:

TERMINAL : GOLD 0.14µm MIN. WITH 1.0 UM MIN NICKEL UNDERPLATE OVERALL
 FITTING NAIL : 1.5 UM MIN TIN WITH 1.0UM MIN NICKEL UNDERPLATE OVERALL.

3. PRODUCT SPECIFICATION: PS-78171-010

4. PACKAGING SPECIFICATION: TAPE & REEL PACKAGING

5. MATES WITH MOLEX PART NUMBER 78172-00**

6. 3 CIRCUITS IS SHOWN FOR ILLUSTRATION PURPOSE ONLY

7. SOLDERTAIL AND FITTING NAIL COPLANARITY : 0.10 MM MAX TO BE MEASURED BY PLACING THE CONNECTOR ON A FLAT GAUGED SURFACE.

APPLY FLUX ANTI-WICKING SOLUTION ON HOUSING BEFORE TERMINAL ASSEMBLY.

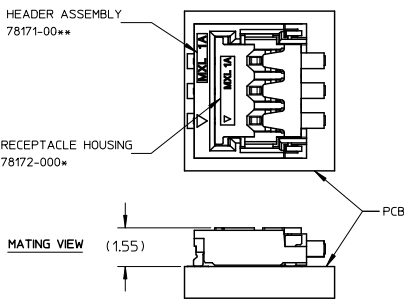

REVISED	EC NO: J2011-0746	DRAWN: CWLAM	CHKD: CHYD	APPR: NUKITA	DESCRIPTION	QUALITY SYMBOLS		GENERAL TOLERANCES (UNLESS SPECIFIED)		DIMENSION STYLE		SCALE	DESIGN UNITS	THIRD ANGLE PROJECTION
						mm	INCH	mm ONLY	MM ONLY	NTS	METRIC			
						4 PLACES	±	---	±	---	DRAWN BY	DATE	TITLE	
						3 PLACES	±	---	±	---	CWLAM	2007/10/25	1.20MM PITCH, W-T-B PLUG CONNECTOR	
						2 PLACES	±	0.2	±	---	CHECKED BY	DATE		
						1 PLACE	±	0.3	±	---	KSSHANTHA	2007/12/07		
						ANGULAR ± 3°				APPROVED BY		DATE		
						DRAFT WHERE APPLICABLE MUST REMAIN WITHIN DIMENSIONS				NUKITA		2010/10/25		
										MATERIAL NO.		DOCUMENT NO.		SHEET NO.
										SEE TABLE			MOLEX INCORPORATED	1 OF 3
										SIZE A3			SD-78171-008	

10 9 8 7 6 5 4 3 2 1

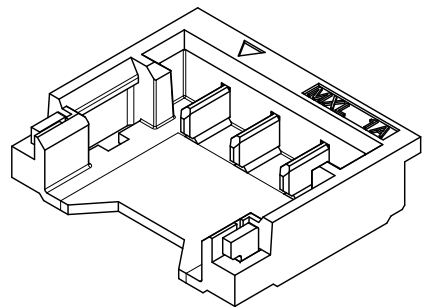
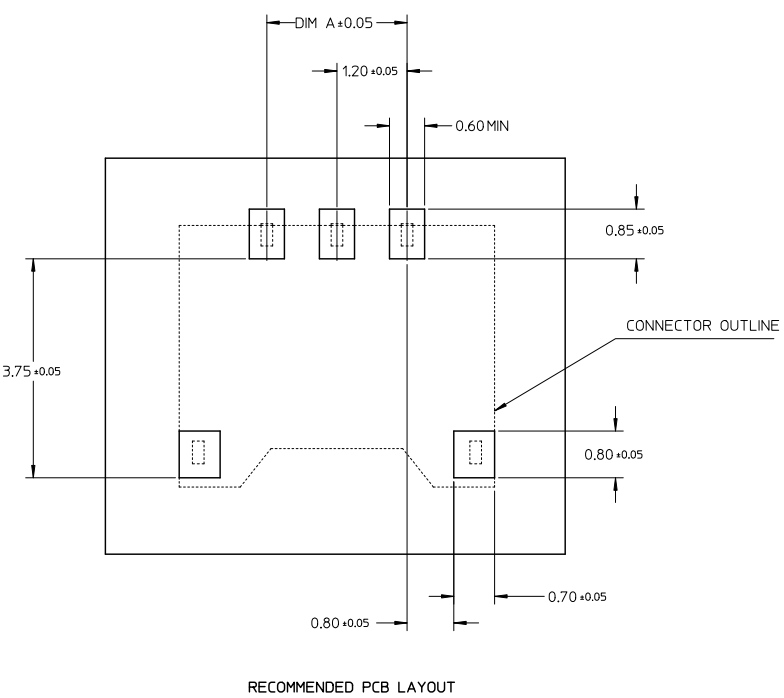

REVISED E.C. NO: J2011-0746 2010/12/02 DRAWN: CWLAM CHYK: APPR: NUKITA 2011/03/17	QUALITY SYMBOLS ▽=0 ▽=0	GENERAL TOLERANCES (UNLESS SPECIFIED)		DIMENSION STYLE MM ONLY		SCALE NTS	DESIGN UNITS METRIC	THIRD ANGLE PROJECTION	
		4 PLACES ± --- ± ---	mm INCH	DRAWN BY CWLAM	DATE 2007/10/25	TITLE 1.20MM PITCH, W-T-B PLUG CONNECTOR			
		3 PLACES ± --- ± ---		CHECKED BY KSSHANTHA	DATE 2007/12/07	MOLEX INCORPORATED			
		2 PLACES ± 0.2 ± --- 1 PLACE ± 0.3 ± ---		APPROVED BY NUKITA	DATE 2010/10/25	MATERIAL NO. SEE TABLE	DOCUMENT NO. SD-78171-008	SHEET NO. 2 OF 3	
DRAFT WHERE APPLICABLE MUST REMAIN WITHIN DIMENSIONS		THIS DRAWING CONTAINS INFORMATION THAT IS PROPRIETARY TO MOLEX INCORPORATED AND SHOULD NOT BE USED WITHOUT WRITTEN PERMISSION							

9 8 7 6 5 4 3 2 1

10 9 8 7 6 5 4 3 2 1

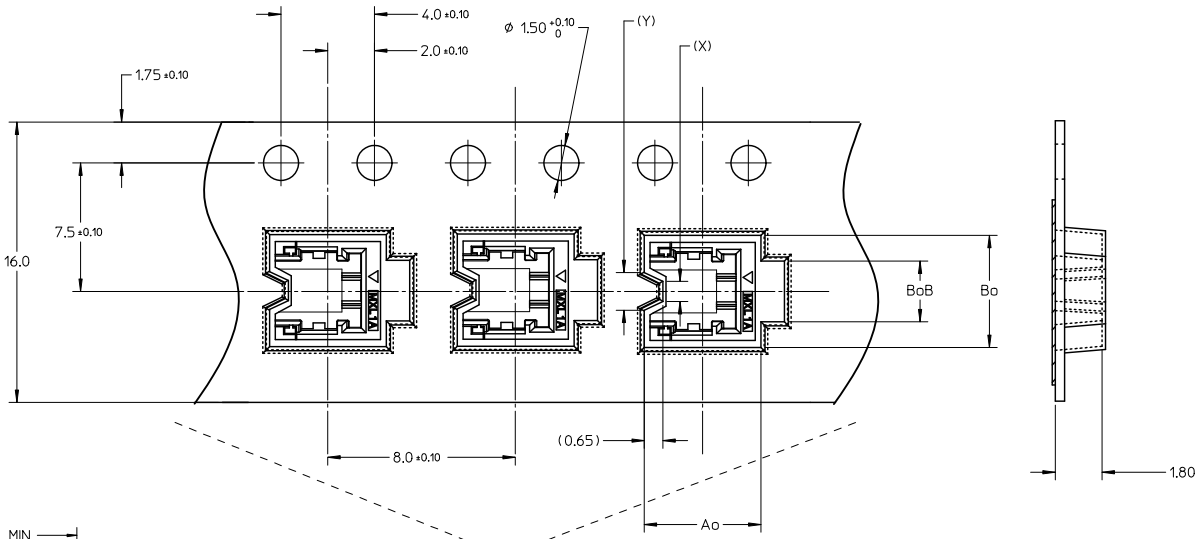

NOTES:

1. LEADER AND TRAILER TAPE

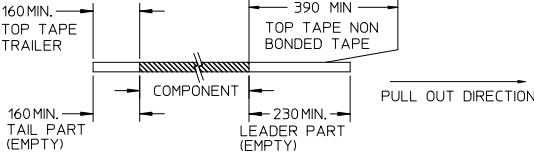

2. PEELING OFF FORCE OF THE TOP TAPE: 20 - 80gf. (PEELING DIRECTION AS SHOWN IN FOLLOWING FIGURE)

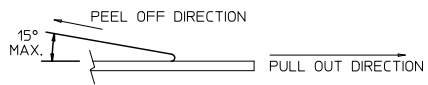

- 3. TAPE AND REEL SPECIFICATION IS AS PER EIA-481.
- 4. TAPE AND REEL QUANTITY : 4500 PCS/ REEL.
- 5. MATERIAL : CARRIER TAPE : PP CLEAR
REEL / FLANGE : PS. COLOUR : BLACK
- 6. Ao & Bo ARE MEASURED ON A PLANE 0.3MM ABOVE THE BOTTOM OF THE POCKET.

CKT	Ao	Bo	BoB	(X)	(Y)	EMBOSS P/N	TOP TAPE P/N	REEL P/N
2	5.0	4.7	2.6	0.74	1.54	89990-2525	59499 -0102	89990-6802
3	5.0	5.9	3.8	1.94	2.74	89990-2526		
4	5.0	7.1	5.0	3.14	3.94	89990-2527		
5	5.0	8.3	6.2	4.34	5.14	89990-2529		

REVISED EIC NO: J2011-0746 2010/12/02 DRAWN: C/LAM CHYD: APPR: NUKITA 2011/03/17	QUALITY SYMBOLS	GENERAL TOLERANCES (UNLESS SPECIFIED)	DIMENSION STYLE	SCALE	DESIGN UNITS	THIRD ANGLE PROJECTION
	▽=0 ▽=0	mm INCH 4 PLACES ± --- ± --- 3 PLACES ± --- ± --- 2 PLACES ± 0.2 ± --- 1 PLACE ± 0.3 ± --- ANGULAR ± 3°	MM ONLY	NTS	METRIC	
	DRAFT WHERE APPLICABLE MUST REMAIN WITHIN DIMENSIONS	DRAWN BY: C/LAM DATE: 2007/10/25 CHECKED BY: KSSHANTHA DATE: 2007/12/07 APPROVED BY: NUKITA DATE: 2010/10/25	TITLE	1.20MM PITCH, W-T-B PLUG CONNECTOR		
		MATERIAL NO. SEE TABLE DOCUMENT NO. SD-78171-008 SHEET NO. 3 OF 3	MOLEX INCORPORATED THIS DRAWING CONTAINS INFORMATION THAT IS PROPRIETARY TO MOLEX INCORPORATED AND SHOULD NOT BE USED WITHOUT WRITTEN PERMISSION			

9 8 7 6 5 4 3 2 1