

SOLID PIN TERMINAL
42023-1***

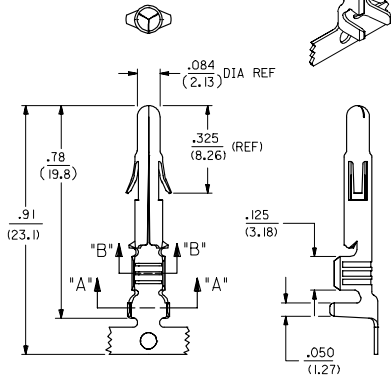

SPLIT PIN TERMINAL
42023-2***

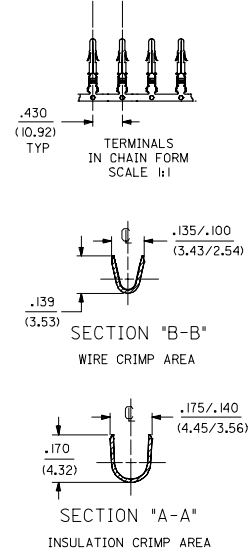
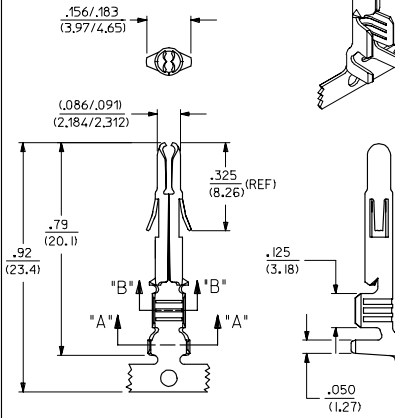

SEE SHEET2 FOR CHART, MATERIAL, PLATING, NOTES, AND CRIMP OPTIONS

IEC NO: 12005-0202 DRAWN: SUDHIR 2004/09/27 CHKD: KPRASAD 2004/09/28 APPR: KPRASAD 2004/09/28	QUALITY SYMBOLS ▽=0 ▽=0	GENERAL TOLERANCES (UNLESS SPECIFIED)		DIMENSION STYLE IN/MM	SCALE 4:1	DESIGN UNITS INCH	THIRD ANGLE PROJECTION						
		4 PLACES ±--- ±---	3 PLACES ±--- ±.010	2 PLACES ±0.25 ±.015	1 PLACE ±0.38 ±---	ANGULAR ±1/2°	DRAWN BY SUDHIR	DATE 2004/09/24	CHECKED BY KPRASAD	DATE 2004/09/24	APPROVED BY KPRASAD	DATE 2004/09/24	TITLE TERMINAL, PIN .084/(2.13) DIA. SERIES
		DRAFT WHERE APPLICABLE MUST REMAIN WITHIN DIMENSIONS		MATERIAL NO. SEE CHART	DOCUMENT NO. SD-42023-****	SHEET NO. 1 OF 2	MOLEX INCORPORATED						
		THIS DRAWING CONTAINS INFORMATION THAT IS PROPRIETARY TO MOLEX INCORPORATED AND SHOULD NOT BE USED WITHOUT WRITTEN PERMISSION											

ENG. NO.	EDP NO.	FINISH (REF)	CONTACT AREA (REF)	CRIMP AREA (REF)	MATERIAL (REF)	TERMINAL TYPE	WIRE SIZE	INSULATION DIAMETER
X-42023-1A1	PRELIMINARY	SDES-88-P901	----	----	C26000	SOLID	#14-#20 AWG	.060-.130
X-42023-1A1L	PRELIMINARY	SDES-88-P901	----	----	C26000	SOLID	#14-#20 AWG	.060-.130
42023-2A1	002-08-2003	SDES-88-P901	----	----	C26000	SPLIT	#14-#20 AWG	.060-.130
42023-2A1L	002-08-2004	SDES-88-P901	----	----	C26000	SPLIT	#14-#20 AWG	.060-.130
42023-2B1	002-08-2005	SDES-88-P901	----	----	C51000	SPLIT	#14-#20 AWG	.060-.130
42023-2B1L	002-08-2006	SDES-88-P901	----	----	C51000	SPLIT	#14-#20 AWG	.060-.130
42023-2A2	002-08-2007	SEE NOTE 5	.000030 MIN GOLD	.000100 MIN MATTE TIN	C26000	SPLIT	#14-#20 AWG	.060-.130
42023-2A2L	002-08-2008	SEE NOTE 5	.000030 MIN GOLD	.000100 MIN MATTE TIN	C26000	SPLIT	#14-#20 AWG	.060-.130
42023-2B2	002-08-2009	SEE NOTE 5	.000030 MIN GOLD	.000100 MIN MATTE TIN	C51000	SPLIT	#14-#20 AWG	.060-.130
42023-2B2L	002-08-2010	SEE NOTE 5	.000030 MIN GOLD	.000100 MIN MATTE TIN	C51000	SPLIT	#14-#20 AWG	.060-.130

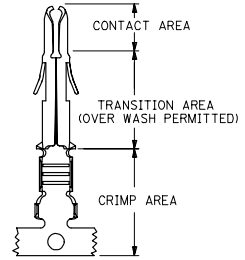

PLATING REGIONS
 APPLIES TO GOLD PLATED TERMINALS ONLY

- NOTES:**
- PIN TERMINALS FOR USE WITH THE .084/(2.13) SERIES HOUSINGS:
 PLUG (42021-**) CAP (42022-**)
 - PIN TERMINALS MATE WITH SOCKET TERMINALS: .084/(2.13) DIA. SERIES (42024-*****).
 - TERMINALS FINISHED IN CHAIN UNLESS SPECIFIED LOOSE. 'L' SUFFIX INDICATES LOOSE FORM. (SEE TABLE)
 - MATERIAL: .012/(0.30) THICK STRIP:
 A = BRASS, *C26000, PER SMES-124-C7.
 B = PHOSPHOR BRONZE, *C51000, PER SMES-124-E7.
 - FINISH:
 1 = HOT TIN DIP 20 m.l./(.51 MICRONS) MINIMUM (PER SDES-88-P901).
 2 = 30 M.I (0.75 MICRONS) MIN GOLD & 100 M.I (2.50 MICRONS) MIN SELECT TIN
 50 M.I (1.25 MICRONS) MIN NICKEL OVERALL
 - CRIMP RANGE: SEE CHAIR.
 - PRODUCT SPECIFICATION PS-42022-0001 APPLIES.

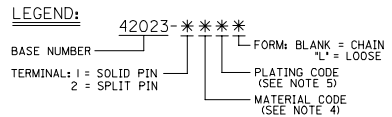

IEC NO: 12005-0302 DRAWN: SUDHIR 2004/09/27 CHKD: KPRASAD 2004/09/27 APPR: KPRASAD 2004/09/27 REV	QUALITY SYMBOLS	GENERAL TOLERANCES (UNLESS SPECIFIED)	DIMENSION STYLE IN/MM	SCALE ---	DESIGN UNITS INCH	THIRD ANGLE PROJECTION
	▽=0	4 PLACES ±--- ±---	DRAWN BY SUDHIR DATE 2004/09/27	TITLE TERMINAL, PIN .084/(2.13) DIA. SERIES		
	▽=0	3 PLACES ±--- ±---	CHECKED BY KPRASAD DATE 2004/09/27	MATERIAL NO. SEE CHART DOCUMENT NO. SD-42023-**** SHEET NO. 2 OF 2		
		2 PLACES ±--- ±---	APPROVED BY KPRASAD DATE 2004/09/27	MATERIAL NO. SEE CHART DOCUMENT NO. SD-42023-**** SHEET NO. 2 OF 2		
	1 PLACE ±--- ±---	ANGULAR ±---°	DRAFT WHERE APPLICABLE MUST REMAIN WITHIN DIMENSIONS			
THIS DRAWING CONTAINS INFORMATION THAT IS PROPRIETARY TO MOLEX INCORPORATED AND SHOULD NOT BE USED WITHOUT WRITTEN PERMISSION						