

10 9 8 7 6 5 4 3 2 1

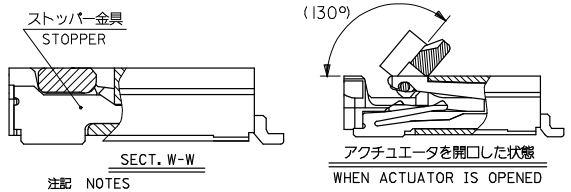
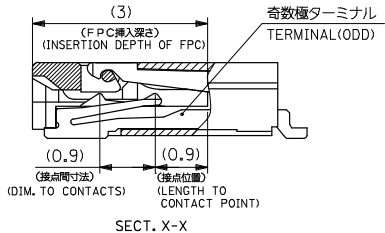
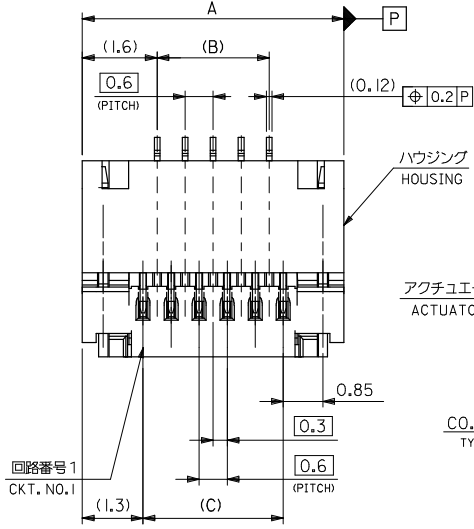

注記 NOTES

1. 使用材料 MATERIAL
 ハウジング HOUSING : LCP , UL94V-0
 アクチュエータ ACTUATOR : PA46 , UL94V-0
 ターミナル : リン青銅 (t=0.12) , ニッケル下地 金メッキ
 TERMINAL : PHOSPHOR BRONZE, GOLD OVER NICKEL PLATING.
 金具 : リン青銅 (t=0.2) , ニッケル下地 銅メッキ
 STOPPER : PHOSPHOR BRONZE, TIN OVER NICKEL PLATING.

2. ソルダータール半田付け面のズレ量は、基準面 [R] に対し、
 上方向 OMAX , 下方向 0.1 MAXIMUM とする。
 又、相互のバラツキ量は 0.1 MAXIMUM とする。
 MISALIGNMENT OF SOLDER TAILS AND FITTING NAILS FROM [R]
 UPPER DIRECTION : 0 MAX. , LOWER DIRECTION : 0.1 MAXIMUM
 OFFSET BETWEEN SOLDER TAILS AND FITTING NAILS : 0.1 MAXIMUM

3. 一般公差 : ±0.3
 GENERAL TOLERANCES : ±0.3

4. 本製品は 54809-**67 の鉛フリー品である。
 THIS PRODUCT IS LEAD FREE OF 54809-**67.

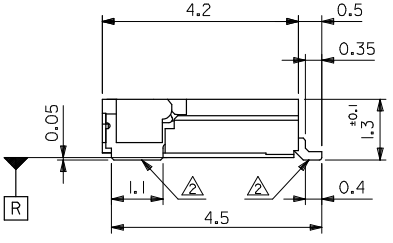
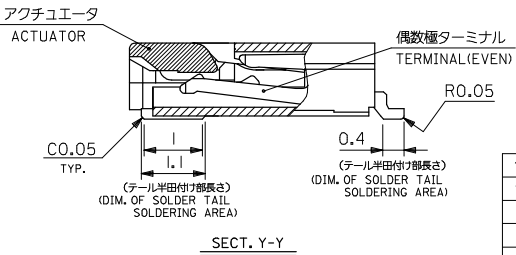
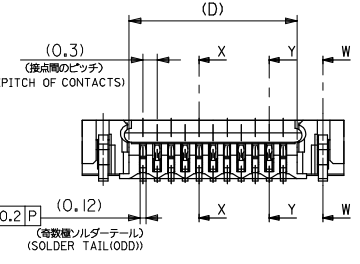

18.6	18.0	17.4	20.6	54809-6175	54809-6169	61
15.6	15.0	14.4	17.6	54809-5175	54809-5169	51
13.8	13.2	12.6	15.8	54809-4575	54809-4569	45
12.0	11.4	10.8	14.0	54809-3975	54809-3969	39
11.4	10.8	10.2	13.4	54809-3775	54809-3769	37
10.8	10.2	9.6	12.8	54809-3575	54809-3569	35
10.2	9.6	9.0	12.2	54809-3375	54809-3369	33
9.6	9.0	8.4	11.6	54809-3175	54809-3169	31
8.4	7.8	7.2	10.4	54809-2775	54809-2769	27
7.8	7.2	6.6	9.8	54809-2575	54809-2569	25
6.6	6.0	5.4	8.6	54809-2175	54809-2169	21
6.0	5.4	4.8	8.0	54809-1975	54809-1969	19
4.8	4.2	3.6	6.8	54809-1575	54809-1569	15
3.6	3.0	2.4	5.6	54809-1175	54809-1169	11
				EMBOSSED TAPE		
				ORDER No. オーダー番号		
				MATERIAL NO.		
				CIRCUITS		

REVISED EC NO: J2008-4034 DRAWN BY: HIRAHARA CHECKED BY: CHYKO:THARYAMA APPROVED BY: APPR:NIKI:TA 2008/05/28 2008/05/28 2008/05/28	GENERAL TOLERANCES (UNLESS SPECIFIED)		DIMENSION STYLE MM ONLY		SCALE ---	DESIGN UNITS METRIC	THIRD ANGLE PROJECTION
	10 UNDER	±0.2	DRAWN BY TUENO	DATE '04/02/10	TITLE 0.3 FPC CONN E/O HSG ASSY GOLD PLT H=1.3 -LEAD FREE-		
	10 OVER	±0.25	CHECKED BY MSASAO	DATE '04/02/10	MOLEX INCORPORATED		
	30 OVER	±0.3	APPROVED BY MSASAO	DATE '04/02/10	DOCUMENT NO. SD-54809-038		
	ANGULAR ±3°		MATERIAL NO. SEE TABLE		SHEET NO. 1 OF 3		
DRAFT WHERE APPLICABLE MUST REMAIN WITHIN DIMENSIONS				THIS DRAWING CONTAINS INFORMATION THAT IS PROPRIETARY TO MOLEX INCORPORATED AND SHOULD NOT BE USED WITHOUT WRITTEN PERMISSION			

10 9 8 7 6 5 4 3 2 1

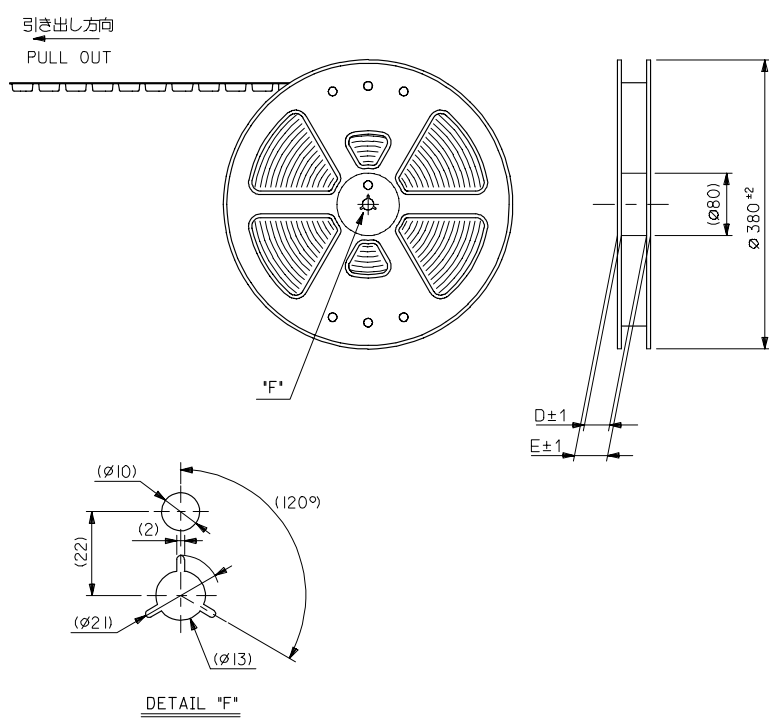

注記 NOTES

1. 製品詳細寸法については、図面SD-54809-038を参照下さい。
RE DETAILED DIMENSION, SEE SD-54809-038.
2. 梱包数量：2500個/リール
NUMBER OF CONNECTORS : 2500PCS/REEL
3. リードテープ長さ LEAD TAPE LENGTH

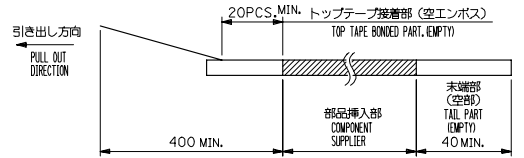

4. トップテープの剥離強度：0.1N~1.3N (10gf~130gf)
(剥離方向は下図参照)
尚、本規格値は出荷時に適用。(但し、輸送時に剥離が発生しないこと。)
PEELING FORCE OF TOP TAPE : 0.1N~1.3N(10gf~130gf)
(PEELING DIRECTION AS SHOWN IN FOLLOWING FIG.)
THIS REQUIREMENT SHOULD BE APPLIED AT SHIPMENT.
PEEL OFF SHOULD NOT BE ALLOWED, DURING TRANSPORTATION.

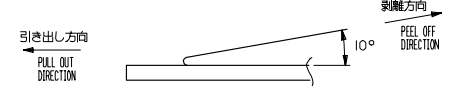

5. 材料 (MATERIAL)
キャリアテープ (CARRIER TAPE) : ポリプロピレン (POLYPROPYLENE)
トップテープ (TOP TAPE) : PET, PE, PEF
リール (REEL) : ポリスチレン (PS) <リサイクル材を含む>
POLYSTYRENE(PS) <RECYCLE MATERIAL CONTAINED>
6. 本製品は 54809-**-95 の鉛フリー品である。
THIS PRODUCT IS LEAD FREE OF 54809-**-95.

REVISED EC NO: J2006-0662 DRAWN: HABEI CHKD: KTOYODA APPR: NUKITA	DESCRIPTION 2005/08/31 2005/09/01 2005/09/06	GENERAL TOLERANCES (UNLESS SPECIFIED)		DIMENSION STYLE MM ONLY		54809-**-75		MODEL NO.		
		10 UNDER ±0.2		DRAWN BY TUENO DATE '04/02/10		SCALE ---	DESIGN UNITS METRIC	THIRD ANGLE PROJECTION		
		10 OVER 30 UNDER ±0.25		CHECKED BY MSASAO DATE '04/02/10		TITLE EMBSTP PKG FOR 0.3 FPC CONN E/O GOLD PLT H=1.3 -LEAD FREE-				
		30 OVER ±0.3		APPROVED BY MSASAO DATE '04/02/10		MOLEX INCORPORATED				
ANGULAR ±3 °		DRAFT WHERE APPLICABLE MUST REMAIN WITHIN DIMENSIONS		MATERIAL NO. SEE CHART		DOCUMENT NO. SD-54809-039		SHEET NO. 1 OF 4		
B		REV		SIZE A3		THIS DRAWING CONTAINS INFORMATION THAT IS PROPRIETARY TO MOLEX INCORPORATED AND SHOULD NOT BE USED WITHOUT WRITTEN PERMISSION				

10 9 8 7 6 5 4 3 2 1

F F

E E

D D

C C

B B

A A

Rev. D 2004/04/02 9 8 7 6 5 4 3 2 1 EN-02JA(021)

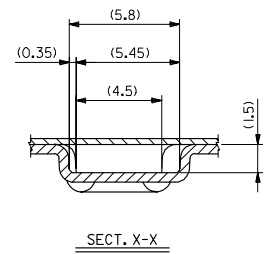
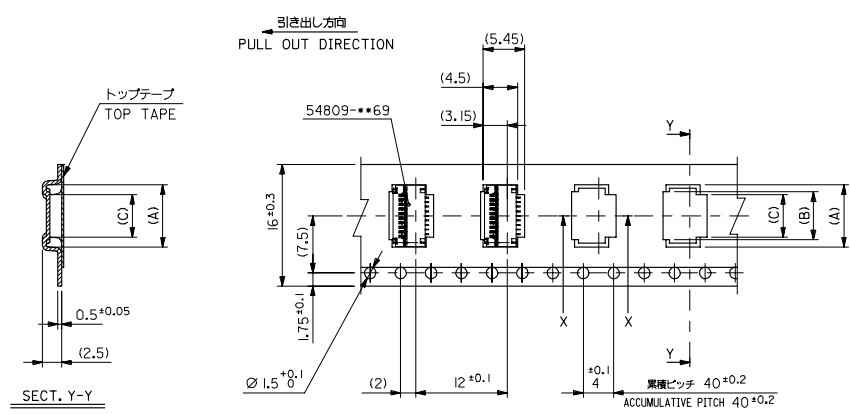

16mm幅キャリアテープ
16mm WIDTH CARRIER TAPE

i6	21.4	17.4	6.2	6.9	8.8	54809-2175	21
			5.6	6.3	8.2	54809-1975	19
			4.4	5.1	7.0	54809-1575	15
キャリアテープ幅 CARRIER TAPE WIDTH	E	D	C	B	A	MATERIAL NO.	部品 CKT.

REVISED EC NO: J2006-0662 DRAWN: HABEI CHKD: KYODA APPR: NUKITA 2005/08/31 2005/09/01 2005/09/06	GENERAL TOLERANCES (UNLESS SPECIFIED)		DIMENSION STYLE MM ONLY		SCALE ---	DESIGN UNITS METRIC	MODEL NO. 54809-***75
	10 UNDER	±0.2	DRAWN BY TUENO	DATE '04/02/10	TITLE EMBSTP PKG FOR 0,3 FPC CONN E/O GOLD PLT H=1.3 -LEAD FREE- MOLEX INCORPORATED		
	10 OVER 30 UNDER	±0.25	CHECKED BY MSASAO	DATE '04/02/10			
	30 OVER	±0.3	APPROVED BY MSASAO	DATE '04/02/10			
	ANGULAR ±3 °		DRAFT WHERE APPLICABLE MUST REMAIN WITHIN DIMENSIONS		MATERIAL NO. SEE CHRAT	DOCUMENT NO. SD-54809-039	SHEET NO. 2 OF 4
THIS DRAWING CONTAINS INFORMATION THAT IS PROPRIETARY TO MOLEX INCORPORATED AND SHOULD NOT BE USED WITHOUT WRITTEN PERMISSION							

10 9 8 7 6 5 4 3 2 1

F F

E E

D D

C C

B B

A A

9 8 7 6 5 4 3 2 1

EN-02JA(021)

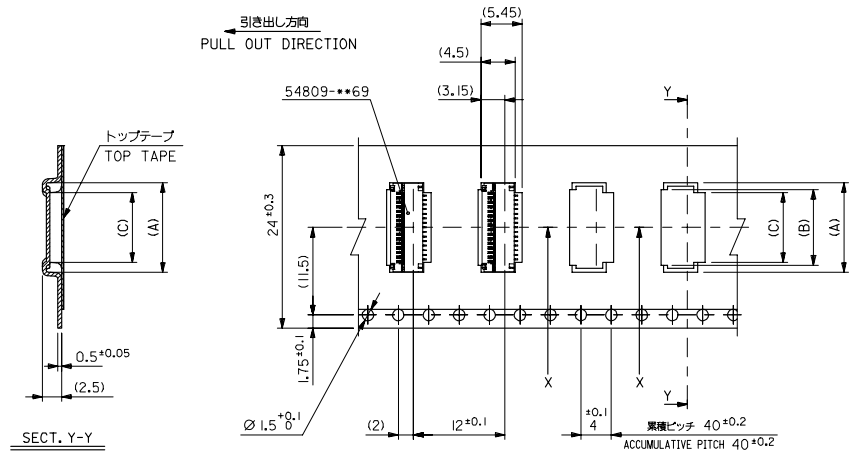

24mm幅キャリアテープ
24mm WIDTH CARRIER TAPE

キャリアテープ幅 CARRIER TAPE WIDTH	E	D	C	B	A	13.4	14.1	16.0	54809-4575	45
						11.6	12.3	14.2	54809-3975	39
						11.0	11.7	13.6	54809-3775	37
						10.4	11.1	13.0	54809-3575	35
						9.8	10.5	12.4	54809-3375	33
						9.2	9.9	11.8	54809-3175	31
						8.0	8.7	10.6	54809-2775	27
						7.4	8.1	10.0	54809-2575	25
MATERIAL NO.						MODEL NO.				

REVISED EC NO. J2006-0662 DRAWN: H. NABEI CHKD: K. TOYODA APPR: N. MIYATA	DESCRIPTION	GENERAL TOLERANCES (UNLESS SPECIFIED)		DIMENSION STYLE MM ONLY		SCALE	DESIGN UNITS	MODEL NO.	
		10 UNDER ±0.2		DRAWN BY TUENO		---	METRIC	54809-**75	
		10 OVER 30 UNDER ±0.25		DATE '04/02/10		TITLE		THIRD ANGLE PROJECTION	
		30 OVER ±0.3		CHECKED BY MSASAO		EMBSTP PKG FOR 0.3 FPC CONN E/O GOLD PLT H=1.3 -LEAD FREE-		MOLEX INCORPORATED	
		ANGULAR ±3 °		DATE '04/02/10		APPROVED BY MSASAO		DOCUMENT NO.	
DRAFT WHERE APPLICABLE MUST REMAIN WITHIN DIMENSIONS		MATERIAL NO. SEE CAHRT		SD-54809-039		SHEET NO. 3 OF 4		THIS DRAWING CONTAINS INFORMATION THAT IS PROPRIETARY TO MOLEX INCORPORATED AND SHOULD NOT BE USED WITHOUT WRITTEN PERMISSION	

10 9 8 7 6 5 4 3 2 1

F F

E E

D D

C C

B B

A A

引き出し方向
PULL OUT DIRECTION

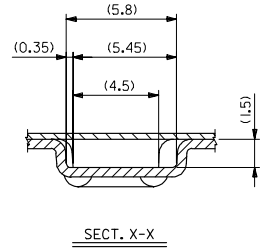
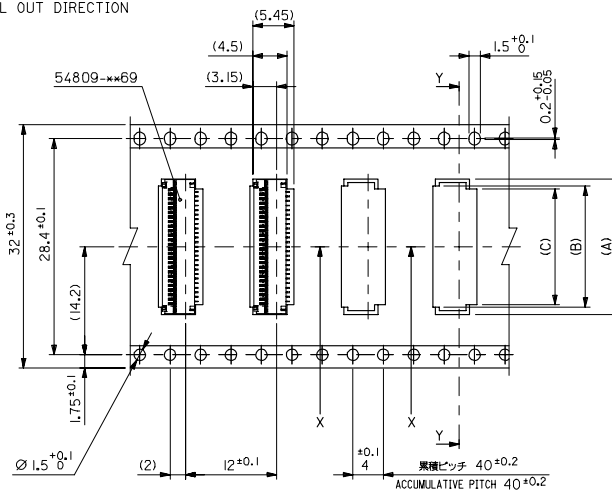
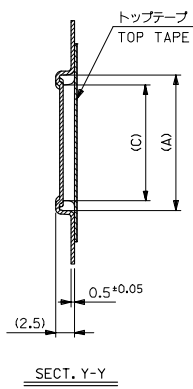

32mm幅キャリアテープ
32mm WIDTH CARRIER TAPE

32	37.4	33.4	18.2	18.9	20.8	54809-6175	61
キャリアテープ幅 CARRIER TAPE WIDTH	E	D	C	B	A	MATERIAL NO.	部品 CIRCUITS

REVISED EC NO: J2006-0662 DRW: HIRABEI CHK: KATOYODA APPR: NUKITA	2005/08/31 2005/09/01 2005/09/06	GENERAL TOLERANCES (UNLESS SPECIFIED)		DIMENSION STYLE MM ONLY		SCALE ---	DESIGN UNITS METRIC	MODEL NO. 54809-**75	
	10 UNDER ±0.2 10 OVER 30 UNDER ±0.25 30 OVER ±0.3	DRAFT WHERE APPLICABLE MUST REMAIN WITHIN DIMENSIONS		DRAWN BY TUENO DATE '04/02/10		TITLE EMBSTP PKG FOR 0.3 FPC CONN E/O GOLD PLT H=1.3 -LEAD FREE-			
	ANGULAR ±3 °	SEE CHART		CHECKED BY MSASAO DATE '04/02/10		MOLEX MOLEX INCORPORATED			
	MATERIAL NO.	DOCUMENT NO. SD-54809-039		APPROVED BY MSASAO DATE '04/02/10		SHEET NO. 4 OF 4			