

(b)

NOTES:

1. FOR WAVESOLDERING (SOLDER BATH TEMPERATURE 265°C FOR 8 SEC. AND SOLDER PREHEAT 150°C FOR 180 SEC.)
2. IP RATING: IP 67
3. SEALED TO WITHSTAND PRESSURE UP TO 1,45 PSI FOR 30 MINUTES AFTER HIGH TEMPERATURE EXPOSURE
4. METALSHELL: ZINC DIE CAST;
min. 50µm NICKEL PLATING over COPPER
5. INSULATORS: PBT GF UL 94 V-0, BLACK
6. O-RING: SILICONE PER ASTM D2000 70 SHORE A
7. RUBBER GASKET: TPE
8. SEALING COMPOUND: EPOXY RESIN UL 94 V-0; BLACK
9. CONTACTS: COPPER ALLOY PLATING (SEE PART NO);
□ PLEASE ADD 1 for 30µm HARD GOLD over min. 50µm NICKEL
□ PLEASE ADD 3 for 8µm HARD GOLD over min. 50µm NICKEL
10. REAR SPACER CLIPS: COPPER ALLOY;
min. 200µm TIN over 80µm NICKEL
PCB-HOLE: $\varnothing 3,1 \pm 0,1$; PCB THICKNESS 1,6mm
11. HEXLOCKING SCREWS: STAINLESS STEEL
12. PCB-HOLE DRILLINGS and RECOMMENDED PANEL CUT-OUT ON SHEET 2
13. RECOMMENDED TORQUE FOR MOUNTING SCREW
35Ncm (3.1 in.LB) / max.67Ncm (6 in.LB)
14. CONNECTOR IS PART MARKED: 15-00041 CONEC ABC

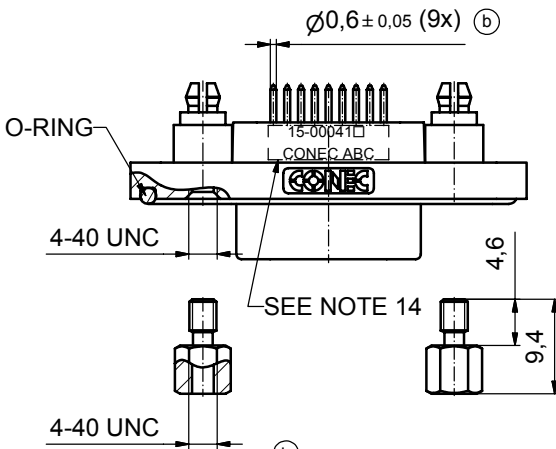
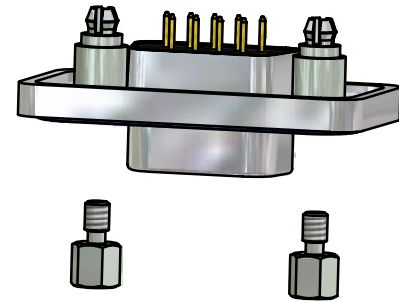
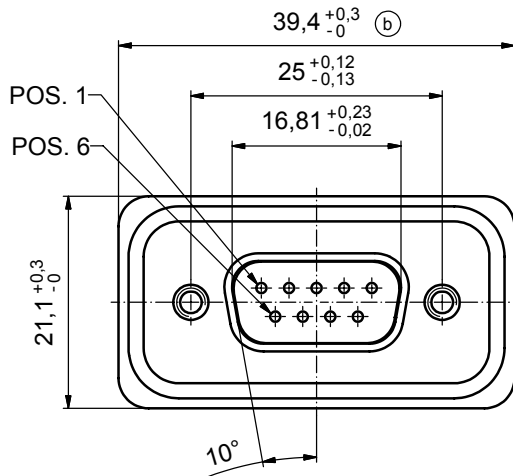
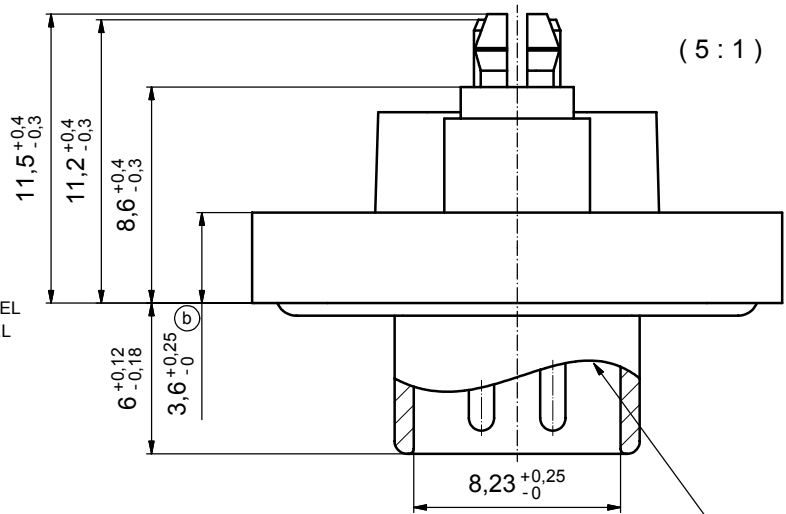

(b)

AT ALL TIMES WATER RESISTANT CONNECTORS NOT IN USE SHOULD BE COVERED WITH A CONEC WATER RESISTANT CAP OR WATER TIGHT HOOD.

Directive 2002/95/EC
"RoHS"
Compliant

APPROVAL # FREIGABE # DEBLOCAGE # AUTORIZACION # APPROVAL	
CUSTOMER APPROVAL DATE:	
NAME:	TITLE:
COMPANY NAME:	
APPROVAL # FREIGABE # DEBLOCAGE # AUTORIZACION # APPROVAL	

THIS DRAWING MAY NOT BE COPIED OR REPRODUCED IN ANY WAY, AND MAY NOT BE PASSED ON TO A THIRD PARTY WITHOUT WRITTEN PERMISSION. OWNERSHIP AND COPYRIGHT OF CONEC GmbH DO NOT ALTER CAD DRAWING BY HAND			
5 x b	A3435	21.09.09	HS
a	Origin		
rev.	description	date	name

tolerance		dim. in mm
date	name	
drawn	17.10.08	Schmidt
appd.	21.10.08	Fischer
norm		
d-old		

scale:	2:1 (5:1)	
material:	see notes	
title:		
D-SUB MALE		
9pos. SOLDER PIN STRAIGHT		
with rear spacer clip and hexlocking screw		
dwg no:	Inventor 10	DIN-A3
	15K1A274	sh: 1
part no:	15-00041 (see note 9)	



P.C.B. HOLE DRILLINGS

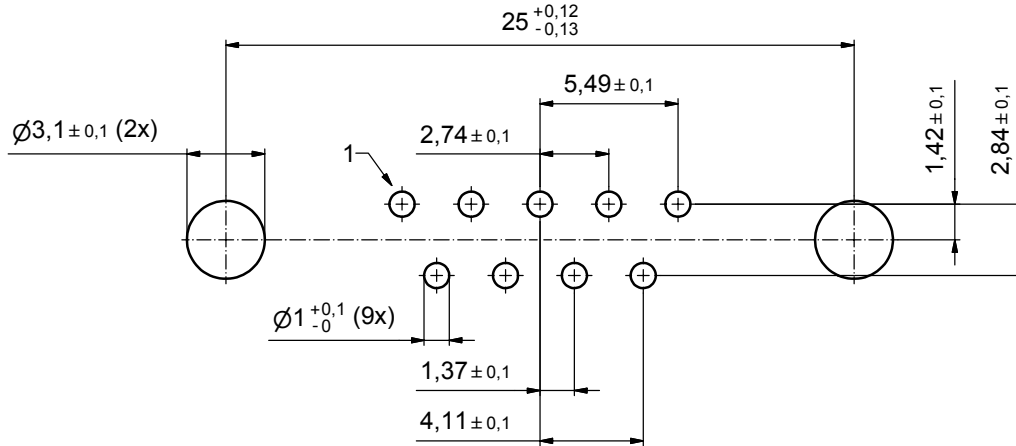

RECOMMENDED PANEL CUT-OUT

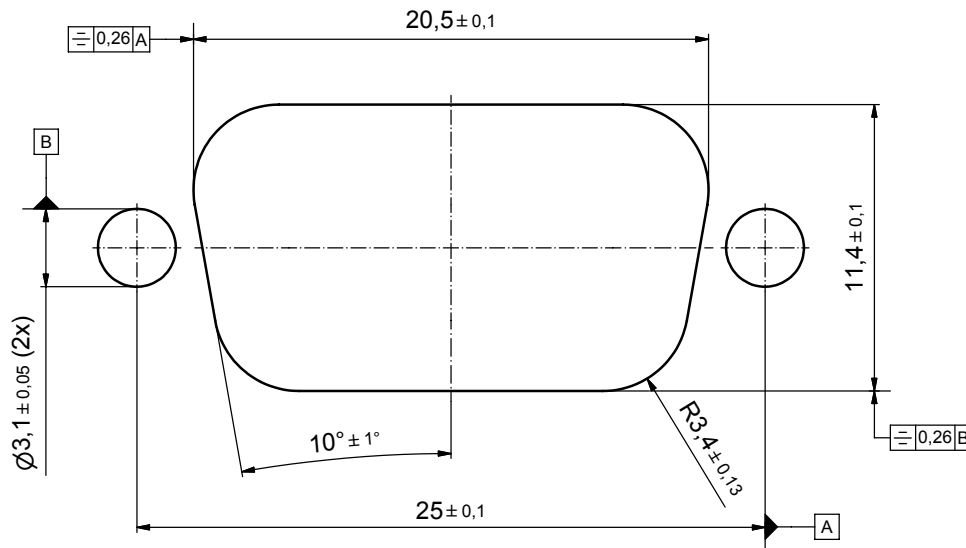

APPROVAL # FREIGABE # DEBLOCAGE # AUTORIZACION # APPROVAL	
CUSTOMER APPROVAL DATE:	
NAME:	TITLE:
COMPANY NAME:	
APPROVAL # FREIGABE # DEBLOCAGE # AUTORIZACION # APPROVAL	

THIS DRAWING MAY NOT BE COPIED OR REPRODUCED IN ANY WAY, AND MAY NOT BE PASSED ON TO A THIRD PARTY WITHOUT WRITTEN PERMISSION. OWNERSHIP AND COPYRIGHT OF CONEC GmbH. DO NOT ALTER CAD DRAWING BY HAND.

rev.	description	date	name
a	Origin		

tolerance		dim. in mm	
date	name	drawn	appd.
17.10.08	Schmidt	21.10.08	Fischer
norm		d-old	

scale:	5:1	
material:	see sheet 1	
title:	P.C.B. HOLE DRILLINGS PANEL CUT-OUT Male 9pos. Solder pin straight	
dwg no:	Inventor 10	DIN-A3
	15K1A274	sh: 2
part no:	see sheet 1	

