

**NOTES:**

- MATERIALS AND FINISHES:**  
 BODY AND BAYONET SLEEVE - BRASS, NICKEL PLATING  
 OUTER CONTACT - BeCu, NICKEL PLATING  
 CONTACT - PHOSPHOR BRONZE, GOLD PLATING  
 FERRULE - COPPER, NICKEL PLATING  
 INSULATOR - PTFE
- ELECTRICAL:**  
 A. IMPEDANCE: 75 OHM  
 B. FREQUENCY RANGE: DC - 3 GHz  
 C. RETURN LOSS: 30 dB MIN  
 D. DIELECTRIC WITHSTANDING VOLTAGE: 1000 VRMS, MIN.  
 E. INSULATION RESISTANCE: 10,000 MΩ MIN
- MECHANICAL:**  
 A. DURABILITY: 500 CYCLES MIN.  
 B. TEMPERATURE RANGE: -65° C TO +165° C
- ENVIRONMENTAL:**  
 A. THERMAL SHOCK PER MIL-STD-202 METHOD 107  
 TEST CONDITION B (EXCEPT HIGH TEMP @200°C)  
 B. VIBRATION: MIL-STD-202 METHOD 204 TEST CONDITION B  
 C. SHOCK: MIL-STD-202 METHOD 213 TEST CONDITION B  
 D. CORROSION: MIL-STD-202 METHOD 101  
 TEST CONDITION B 5% SALT SOLUTION
- PACKAGING:**  
 A. QUANTITY: SINGLE PACK  
 B. MARKING: BAG TO BE MARKED:  
 \*AMPHENOLRF, 34-1017-300 DATE CODE\*
- HIGH DENSITY INSTALLATION/REMOVAL TOOL: 227-T2000-1694A.**
- CABLE ASSEMBLY INSTRUCTIONS:**  
 A. TRIM CABLE AS SHOWN.  
 B. CRIMP CONTACT TO CABLE CENTER CONDUCTOR WITH .042" SQUARE DIE  
 C. CRIMP FERRULE WITH .278" INCH HEX

▷ SHOWS CABLE ENTRY DIMENSIONS.

THIRD ANGLE PROJ.

**REVISIONS**

REV	DESCRIPTION	DATE	ECO	APPR
1	PROTOTYPE RELEASE	10-Mar-10	--	AAP
2	BAYONET SLEEVE DESIGN UPDATED	19-Mar-10	--	AAP
3	A) HEX SIZE HAS BEEN REDUCED TO .278" B) CHANGES TO ACCOMMODATE 9.50MM PITCH	28-Apr-10	--	HP
4	DESIGN UPDATED	12-May-10	--	HP

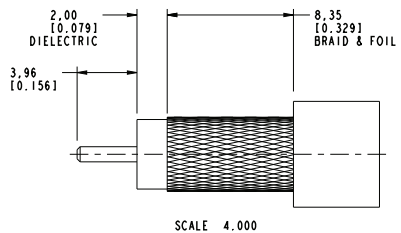

**RECOMMENDED CABLE STRIPPING DIMENSIONS**

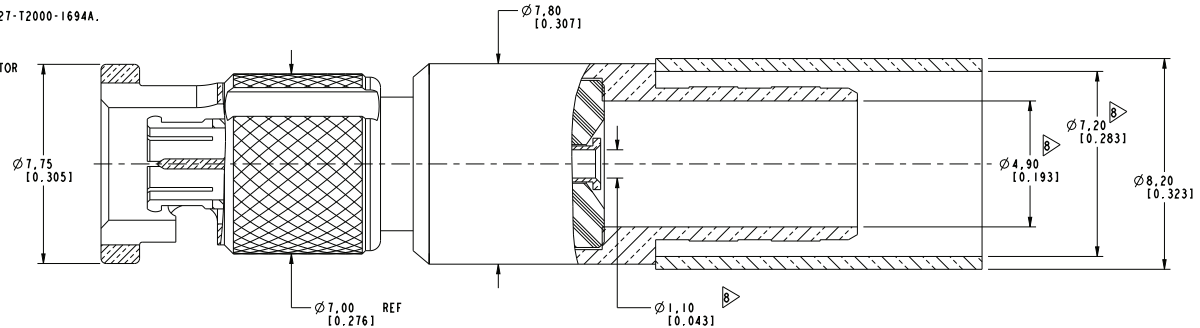
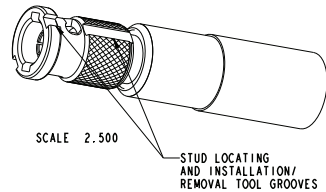

**PRELIMINARY ISSUE**

**CUSTOMER OUTLINE DRAWING**  
 ALL OTHER SHEETS ARE FOR INTERNAL USE ONLY

UNLESS OTHERWISE SPECIFIED, DIMENSIONS ARE IN METRIC AND TOLERANCES ARE: <0.5mm ±0.05mm    0.5 - 6mm ±0.1mm    6 - 30mm ±0.2mm    30 - 120mm ±0.3mm    ANGLES ±1°	MATERIAL	DRAWN	DATE	TITLE HD-BNC STR PLUG FOR 1694A 9.50 MM PITCH	Amphenol RF Danbury CT USA, Taiwan, Taiwan, Shenzhen, China www.amphenolrf.com
	SEE NOTES	A ARUN PRABU	10-Mar-10		
NOTICE - These drawings, specifications, or other data (1) are, and remain the property of Amphenol Corp., (2) must be returned upon request; and (3) are confidential and not to be disclosed to any person other than those to whom they are given by Amphenol Corp. The furnishing of these drawings, specifications, or other data by Amphenol Corp., or to any other person for any purpose is not to be regarded by implication or otherwise in any manner licensing, granting rights to permitting such holder or any other person to manufacture, use or sell any product, process or design, patented or otherwise, that may in any way be related to or disclosed by said drawings, specifications, or other data.	REFERENCE	ENGINEER	DATE	SCALE: 6.8:1.0    SHEET 2 OF 2	DRAWING NO. 34-1017-300 ITEM NO. 34-1017-300 PART NO. 34-1017-300
	EAR # 3897	A ARUN PRABU	10-Mar-10		
CONFIGURATION LEVEL: Prototype	APPROVED	CAD FILE	DATE	DWG SIZE	REV
FINISH		Root Folder/HD-BNC/34-1017-300		B	4