

10 9 8 7 6 5 4 3 2 1

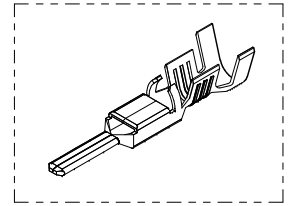
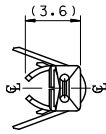
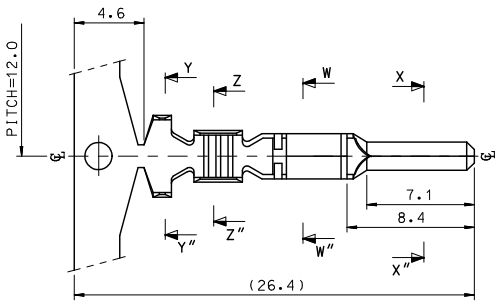

ISOMETRIC VIEW

NOTES.

1. MATERIAL : C BRASS, PRE-TIN PLATED
2. FINISH : 0.8~1.8 μm , Tin(Sn) plating overall
0.3~0.8 μm , Copper(Cu) plating
3. PRODUCT SPECIFICATION : PS-35150-001, PS-35180-002
PS-35180-003, PS-35524-001
4. CRIMPING SPECIFICATION : CS-35745-001
5. RECOMMENDED LENGTH OF WIRE STRIP IS 4.0~4.8mm

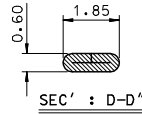

SEC' : D-D

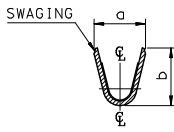
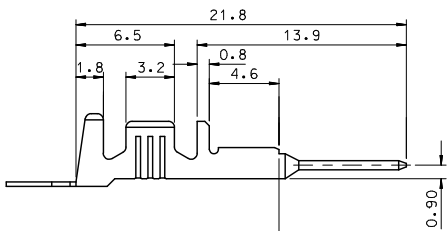

SEC' : X-X

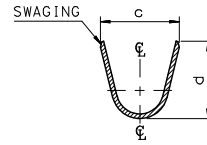

SEC' : Y-Y

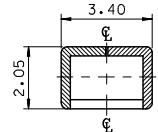

SEC' : C-C

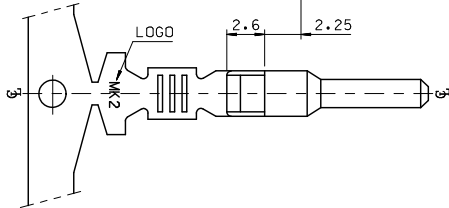

| MATERIAL NO | ENG. No. | AWG | a | b | c | d | PITCH "P" |
|-------------|------------|---------|------|------|------|-----|-----------|
| 357470210 | 35747-0210 | #18-#14 | 3.4 | 3.8 | 5.2 | 4.8 | 12.0 |
| 357470110 | 35747-0110 | #22-#20 | 2.85 | 2.8 | 4.2 | 4.0 | 10.6 |
| 357470410 | 35747-0410 | #24 | 2.2 | 1.75 | 3.85 | 3.5 | 10.6 |

| REVISED E.C. NO.: KOR2009-0151 T.DRAWN: H.PARK01 2009/05/18 C.HYD: 2009/06/18 APPR: YUNSIK/IM 2009/07/01 DESCRIPTION REV | QUALITY SYMBOLS $\blacktriangledown=0$ $\blacktriangledown=0$ | GENERAL TOLERANCES (UNLESS SPECIFIED) <table border="1"> <thead> <tr> <th></th> <th>mm</th> <th>INCH</th> </tr> </thead> <tbody> <tr> <td>4 PLACES</td> <td>\pm ---</td> <td>\pm ---</td> </tr> <tr> <td>3 PLACES</td> <td>\pm ---</td> <td>\pm ---</td> </tr> <tr> <td>2 PLACES</td> <td>\pm 0.2</td> <td>\pm ---</td> </tr> <tr> <td>1 PLACE</td> <td>\pm 0.3</td> <td>\pm ---</td> </tr> <tr> <td colspan="2">ANGULAR</td> <td>\pm 1°</td> </tr> </tbody> </table> | | mm | INCH | 4 PLACES | \pm --- | \pm --- | 3 PLACES | \pm --- | \pm --- | 2 PLACES | \pm 0.2 | \pm --- | 1 PLACE | \pm 0.3 | \pm --- | ANGULAR | | \pm 1° | DIMENSION STYLE MM ONLY DRAWN BY JS.KANG DATE 1998/01/19 CHECKED BY BK.CH01 DATE 1998/01/19 APPROVED BY CW.LEE DATE 1998/01/19 | SCALE 4:1 | DESIGN UNITS METRIC | THIRD ANGLE PROJECTION |
|--|---|---|-----------------------------------|--------------------------------------|------|--|-----------|-----------|----------|-----------|-----------|----------|-----------|-----------|---------|-----------|-----------|---------|--|----------|--|--------------|------------------------|------------------------|
| | | mm | INCH | | | | | | | | | | | | | | | | | | | | | |
| 4 PLACES | \pm --- | \pm --- | | | | | | | | | | | | | | | | | | | | | | |
| 3 PLACES | \pm --- | \pm --- | | | | | | | | | | | | | | | | | | | | | | |
| 2 PLACES | \pm 0.2 | \pm --- | | | | | | | | | | | | | | | | | | | | | | |
| 1 PLACE | \pm 0.3 | \pm --- | | | | | | | | | | | | | | | | | | | | | | |
| ANGULAR | | \pm 1° | | | | | | | | | | | | | | | | | | | | | | |
| DRAFT WHERE APPLICABLE MUST REMAIN WITHIN DIMENSIONS | | | MATERIAL NO. SEE TABLE SIZE A3 | TITLE .070 MALE TERMINAL (B-TYPE) | | MOLEX INCORPORATED DOCUMENT NO. SD-35747-001 SHEET NO. 1 OF 01 | | | | | | | | | | | | | | | | | | |

9 8 7 6 5 4 3 2 1