

9 VOLT TYPE SNAPS SHOWN ABOVE

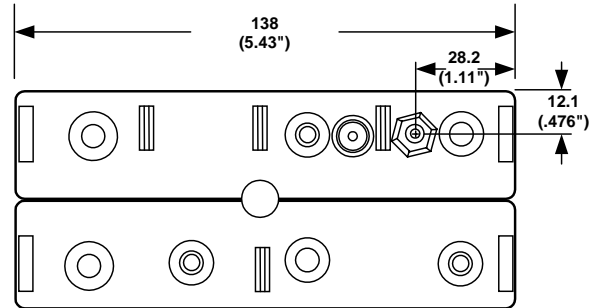

DATE	SYM	REVISION RECORD	AUTH	DR.	CK.

ORDERING CODE **BH48D**

SOLDER LUGS	= L
(6") WIRE LEADS	= W
9VOLT TYPE SNAPS	= SF

SPECIFICATIONS:

Plastic material - polypropylene
 Springs - nickel plated spring steel
 Wire - 152.4 mmRef.Long 26 AWG,
 UL1007, CSA - TR-64, 300V, 80°C.
 Rivets - Brass, nickel plated
 9 Volts Snaps - Brass, nickel plated

Note: Dimensions in mm. (inches)

TOLERANCES (EXCEPT AS NOTED)		 Memory Protection Devices, Inc. 200 Broad Hollow Road, Farmingdale, New York 11735	
DECIMAL	+ .5 (.020")		
FRACTIONAL	+ .8 (.030")	APPROVED BY	
ANGULAR	+ 3°	TITLE	
DATE	09/18/2000	DRAWING NUMBER	
		EIGHT "D" CELL HOLDER BH48DSF	