

Date	SYM	REVISION RECORD	AUTH	DR.	CK.
1/07/06	A	ADDED "ROHS COMPLIANT"	T.B.	B.S.	

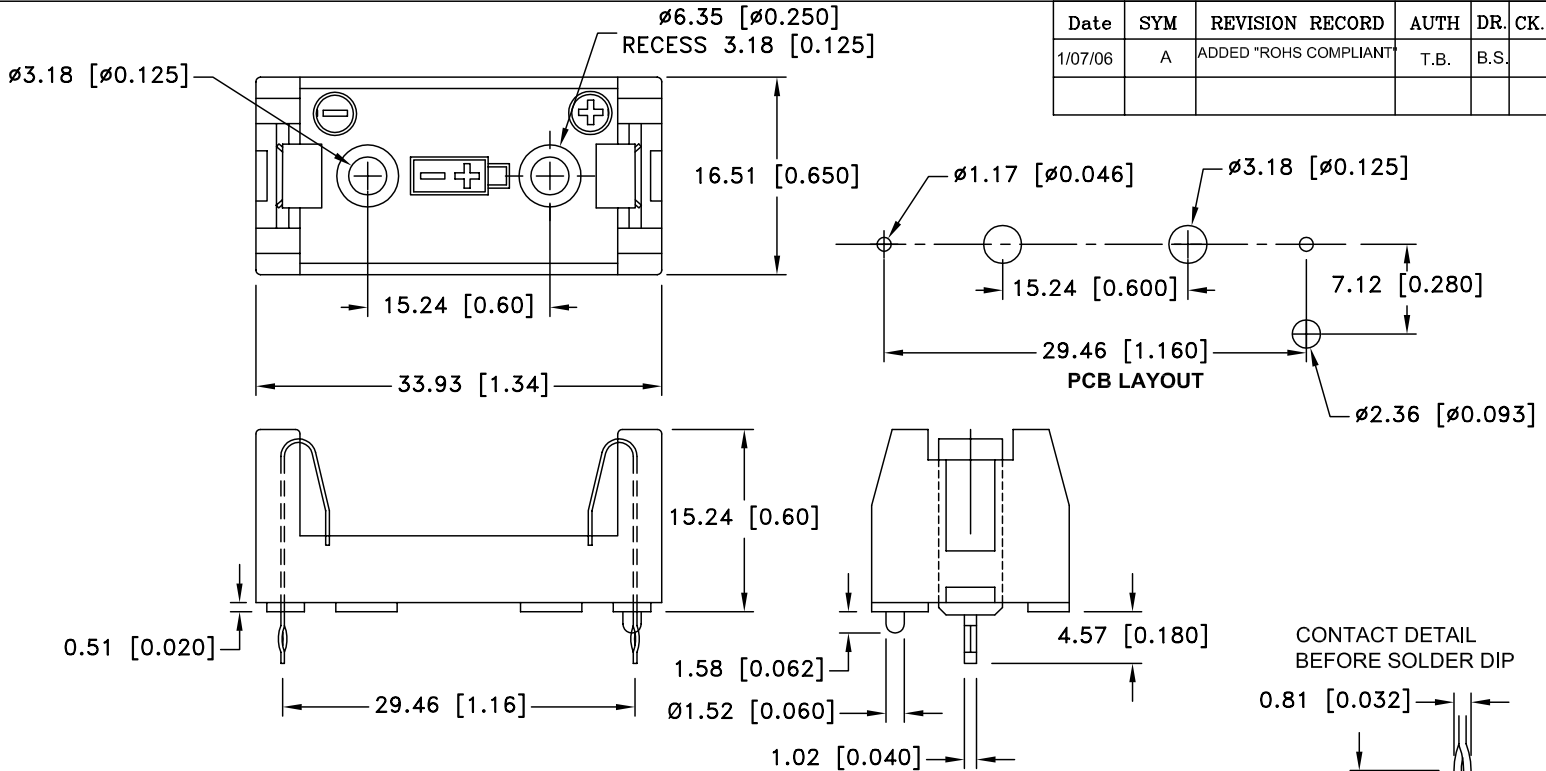

**SPECIFICATIONS:**

HOLDER MATERIAL: BLACK PBT  
 FLAMABILITY RATING: UL94V-0, FILE #E53829  
 CONTACTS: 302 SPRING TEMPER STAINLESS STEEL, NICKLE  
 PLATED OVERALL, SOLDER DIPPED PCB TAILS  
 DIELECTRIC STRENGTH: 560 VOLTS/MIL AT 25°C FOR 5 SEC.  
 TEMPERATURE RANGE: -55°C TO +180°C  
 RESISTANCE TO SOLVENTS: XYLENE, ETHYL, BUTYL, MRTHYL,  
 PROPYL ALCOHOL, ETHYL ACETATE,  
 HEPTANE, TOLUENE, REFRIGERANT

ROHS COMPLIANT

**NOTES:**

EYELET STIMPSON STYLE#A1883 0.110" OD x 0.190" FLANGE  
 FLANGE RECESS Ø0.250" x 0.125" DEEP  
 ACCEPTS STANDARD 2-56 MACHINE SCREWS

Tolerance (Except as noted)	 <b>Memory Protection Devices, Inc</b> 200 Broad Hollow Road, Farmingdale, New York 11735		
decimal ±.5 (.020)		Scale	Drawn By B.S. Approved By T.B.
Fractional ±.8 (.030)	Title 1/2AA BATTERY HOLDER, PCB MOUNTING		
Angular ± 3°	Date 1/07/06	Drawing Number 815-0931	