

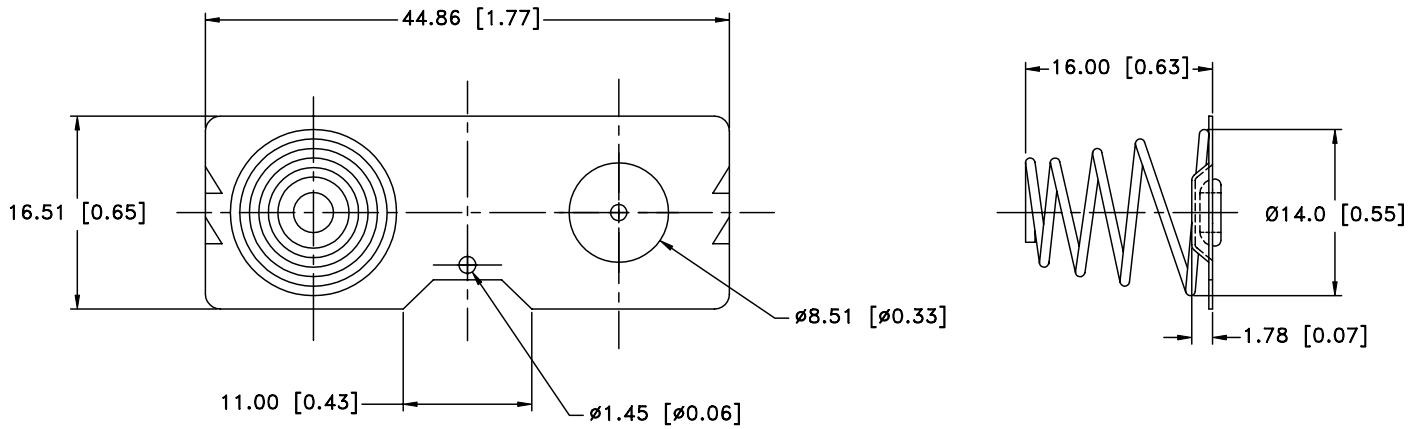

| Date | SYM | REVISION RECORD | AUTH | DR. | CK. |
|----------|-----|------------------------------|------|------|-----|
| 03/15/03 | A | TIN PLATED WAS NICKEL PLATED | T.B. | B.S. | |
| | | | | | |
| | | | | | |
| | | | | | |



- NOTES:**
1. BASE: STEEL, 0.3mm (0.012") THICK. TIN PLTD.
 2. SPRING: STEEL, 0.8mm (0.032") THICK. NICKLE PLTD.

| | | | |
|--------------------------------|---|--------------------------|-----------------------------------|
| Tolerance (Except as noted) |  Memory Protection Devices, Inc 200 Broad Hollow Road, Farmingdale, New York 11735 | | |
| decimal ±.5 (.020) | | Scale | Drawn By B.S. Approved By T.B. |
| Fractional ± .8 (.030) | Title SNT8 "C" CELL BATTERY CONTACT | | |
| Angular ± 3° | Date 03/15/03 | Drawing Number SNT8-3 | |