

PART NUMBER: CSS-0575B
DESCRIPTION: MAGNETIC BUZZER

SPECIFICATIONS

parameter	conditions/description	min	nom	max	units
rated voltage			3		V o-p
operating voltage		2		4	V o-p
current consumption	at rated voltage, 4,000 Hz square wave, ½ duty			110	mA
coil resistance		9	12	15	Ω
sound output	at 10 cm (A-weight free air), rated voltage, 4,000 Hz square wave, ½ duty	75			dBa
rated frequency			4,000		Hz
operating temperature		-30		70	°C
storage temperature		-40		80	°C
dimenstions	5 x 5 x 2.5 mm (L x W x H)				
weight				0.3	g
material	L.C.P. (black)				
terminal	SMD type (Sn plating)				
RoHS	yes				

APPEARANCE DRAWING

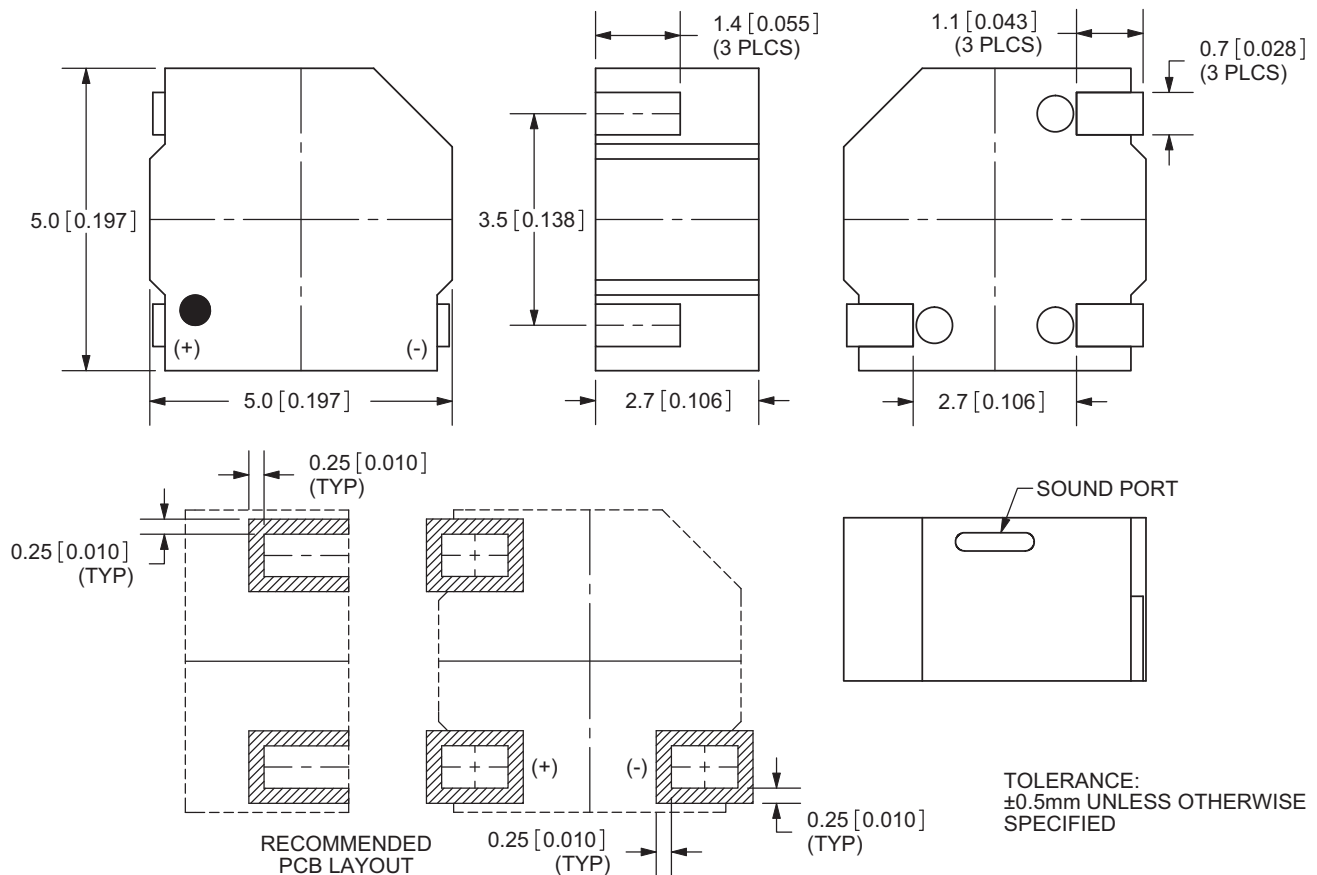

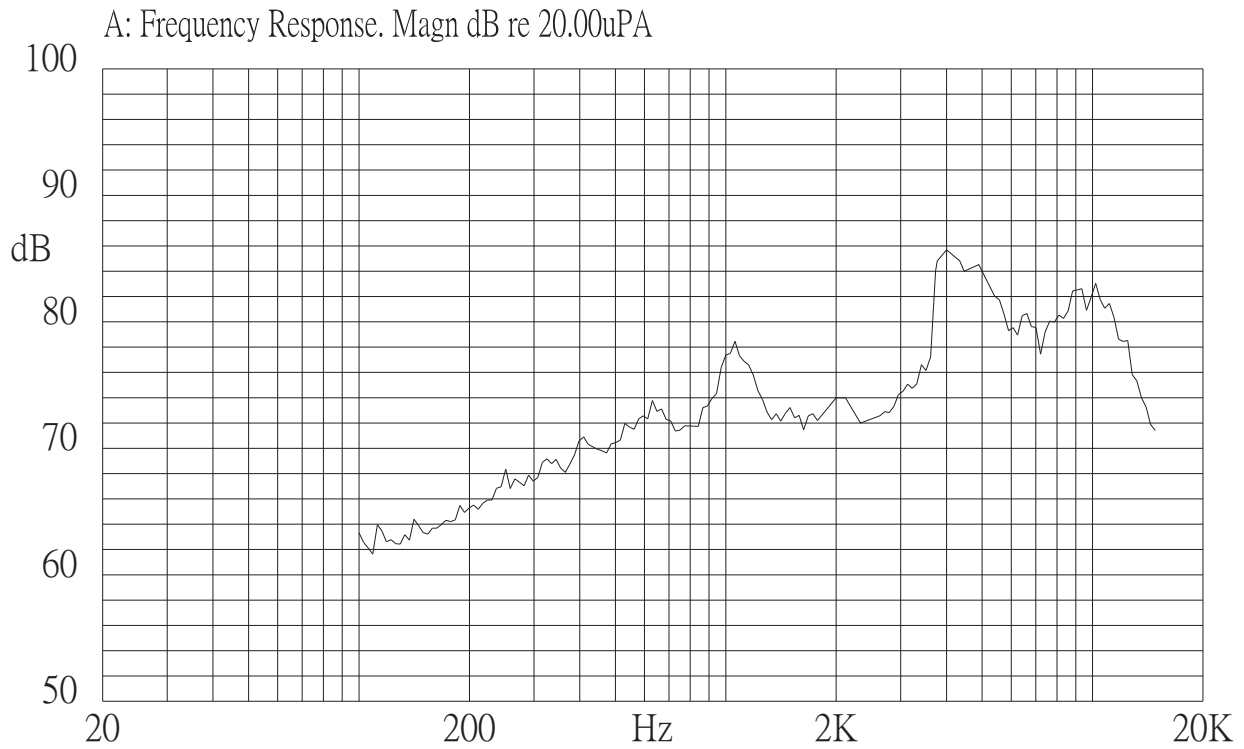
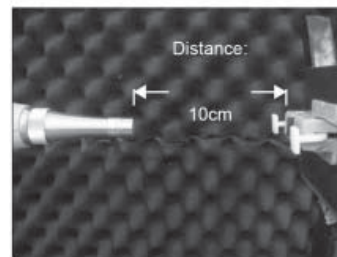
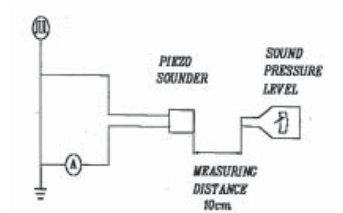
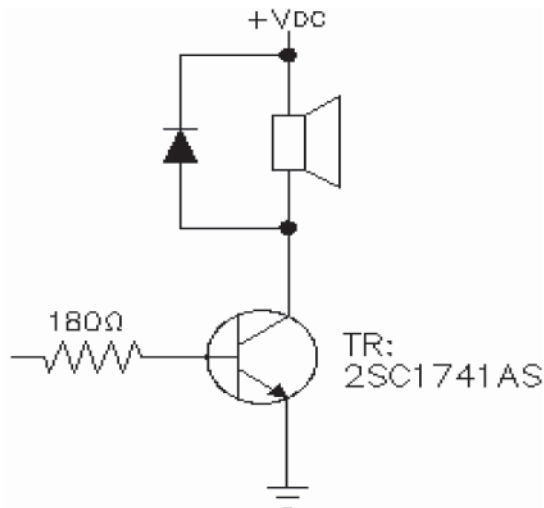
PART NUMBER: CSS-0575B
DESCRIPTION: MAGNETIC BUZZER
FREQUENCY RESPONSE CURVE

MEASUREMENT METHOD
INSPECTION FIXTURE

PART NUMBER: CSS-0575B
DESCRIPTION: MAGNETIC BUZZER

MECHANICAL CHARACTERISTICS

item	test condition	evaluation standard
soldering	Lead terminals are immersed in a solder bath of $+260 \pm 5^\circ\text{C}$ for 3 ± 1 seconds.	95% min. of the lead terminals will be wet with solder. (except the edge of the terminal)
soldering heat resistance	The buzzer will follow the reflow temperature curve to test its reflow thermo stability.	No interference in operation.
terminal mechanical strength	For 10 seconds, the force of 9.8 N (1.0 kg) is applied to each terminal in each axial direction.	No damage or cutting off
vibration test	The buzzer should be measured after a vibration amplitude of 1.5 mm with 10 ~ 55 Hz band of vibration frequency to each of the 3 perpendicular directions for 6 hours.	After any tests, the buzzer will meet specifications without any damage in appearance and the SPL should be within ± 10 dBA of the initial measurements.
drop test	The buzzer without packaging is subjected to 3 drops on each axis from the height of 75 cm onto a 40 mm thick wooden board.	

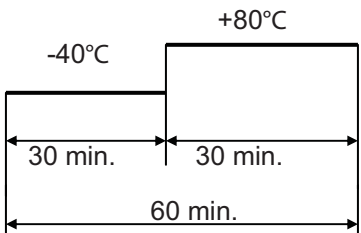
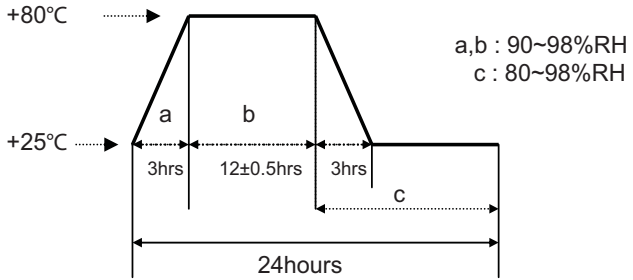
ENVIRONMENT TEST

item	test condition	evaluation standard
high temperature test	After being placed in a chamber at $+80^\circ\text{C}$ for 48 hours.	After any tests, the buzzer will meet specifications without any damage in appearance except SPL. After 4 hours at 25°C , SPL should be within ± 10 dBA of the initial measurements.
low temperature test	After being placed in a chamber at -40°C for 48 hours.	
thermal shock test	The part will be subjected to 10 cycles. One cycle will consist of:	
temperature cycle test	<p>The part will be subjected to 10 cycles. One cycle will consist of:</p> 	
		

PART NUMBER: CSS-0575B
DESCRIPTION: MAGNETIC BUZZER

MECHANICAL CHARACTERISTICS

item	test condition	evaluation standard
operating (life test)	1. Ordinary temperature: The part will be subjected to 100 hours at room temperature (25°C ±10°C) with 3 V, 4,000 Hz applied. 2. High temperature: The part will be subjected to 50 hours of continuous operation at 55°C with 3 V, 4,000 Hz applied. 2. Low temperature: The part will be subjected to 50 hours of continuous operation at -30°C with 3 V, 4,000 Hz applied.	After any tests, the buzzer will meet specifications without any damage in appearance except SPL. After 4 hours at 25°C, SPL should be within ±10 dBA of the initial measurements.

TEST CONDITIONS

standard test conditions	a) Temperature: +5 ~ +35°C	b) Humidity: 45 ~ 85%	c) Pressure: 860 ~ 1060 mbar
judgement test conditions	a) Temperature: +25 ±2°C	b) Humidity: 60 ~ 70%	c) Pressure: 860 ~ 1060 mbar

RECOMMENDED TEMPERATURE PROFILE FOR REFLOW OVEN

Note: 255°C is less than 20 sec., but only pass the lead free reflow once.

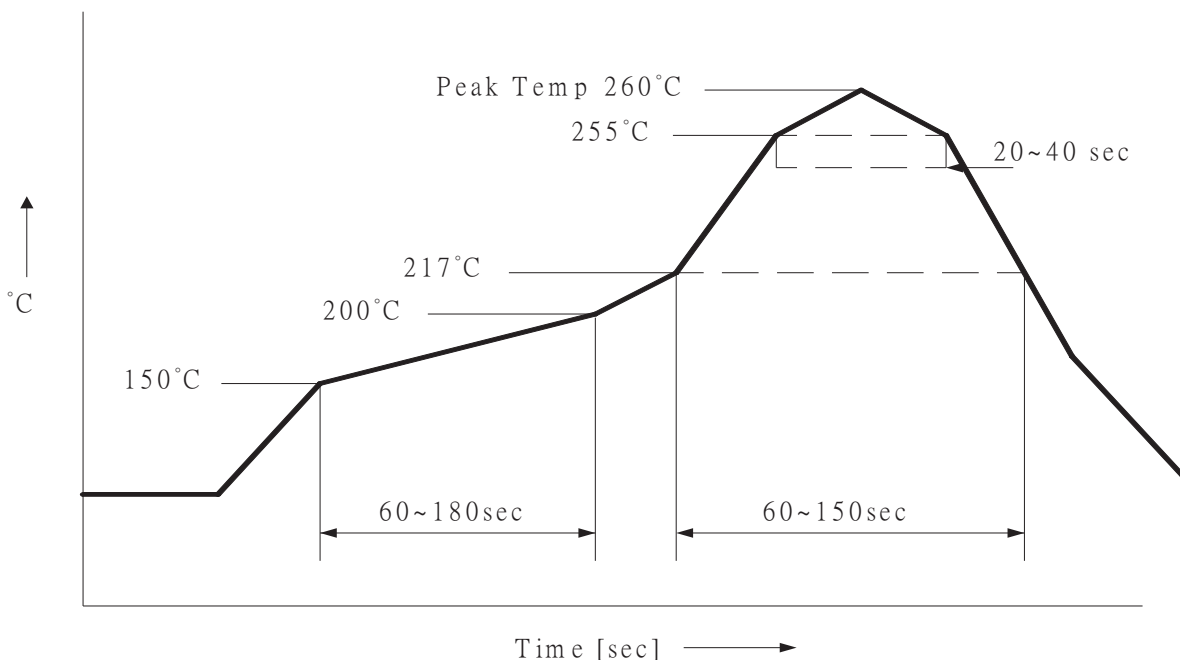

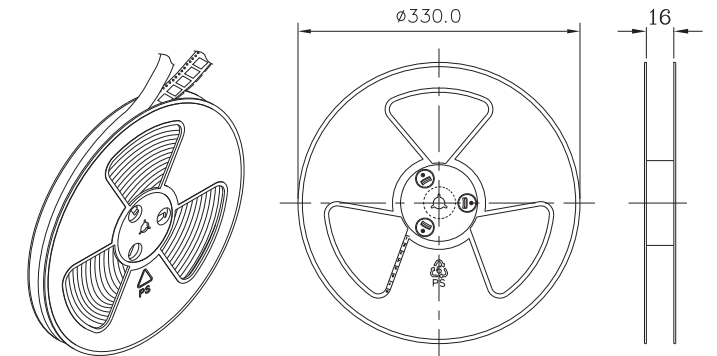
PART NUMBER: CSS-0575B
DESCRIPTION: MAGNETIC BUZZER
PACKAGING

1 Reel : 2500PCS

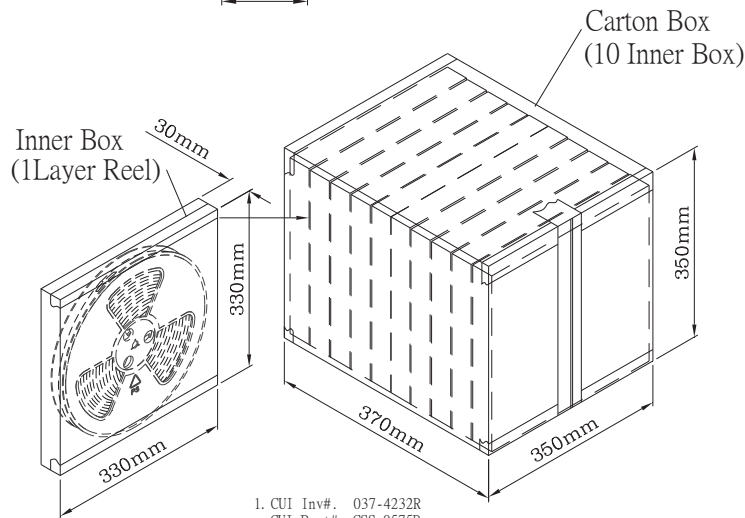
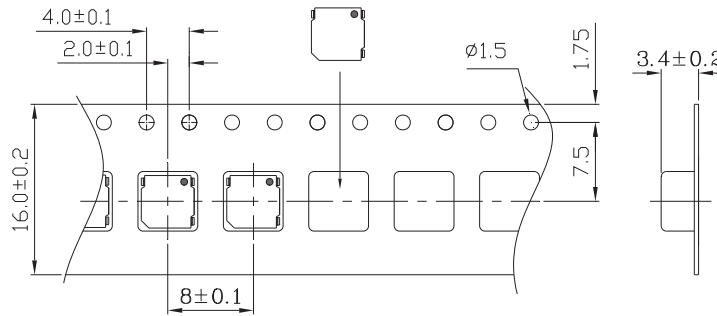

1. CUI Inv#. 037-4232R
CUI Part#. CSS-0575B
2. RoHS Compliant

Inner Box	330mmx330mmx30mm	1x2500PCS=2500PCS
Carton Box	350mmx350mmx370mm	10x2500PCS=25,000PCS