

LOC	DIST	REVISIONS					
E	B	P	LTR	DESCRIPTION	DATE	DWN	APVD
			BA1	NOTE 2 ADDED	30NOV2010	PT	St.P

NOTES:

- FOR FURTHER INFORMATION SEE DATA SHEET FOR C SERIES-HIGH POWER RESISTORS
- WEIGHT 0.400 Kg PER 100 PIECES

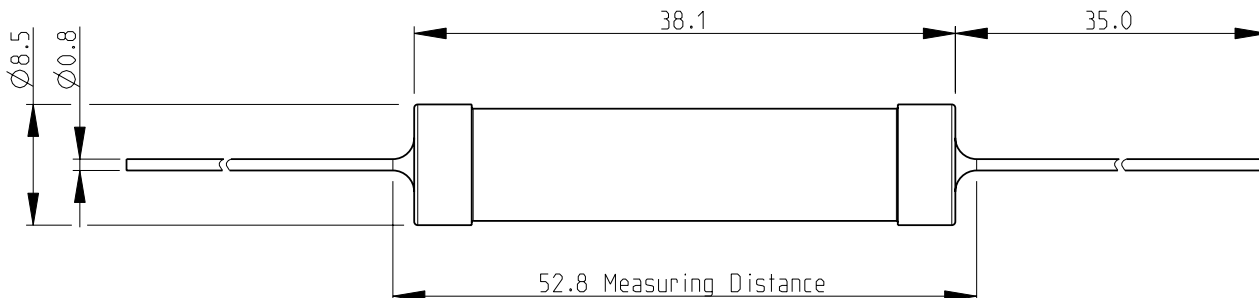

RoHS Compliant

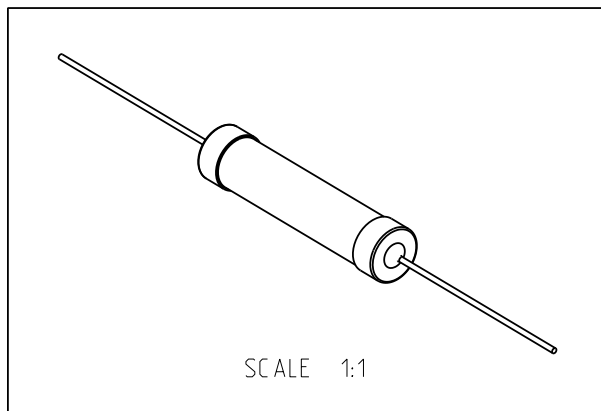

2008

RELEASED FOR PUBLICATION

THIS DRAWING IS UNPUBLISHED.

© COPYRIGHT 2008 BY TYCO ELECTRONICS CORPORATION. ALL RIGHTS RESERVED.

DIMENSIONS: mm		DWN SUBHASH.M 16-Sep-08	MATERIAL -	FINISH -		
TOLERANCES UNLESS OTHERWISE SPECIFIED: 0 PLC ± 0.2 1 PLC ± 0.1 2 PLC $\pm -$ 3 PLC $\pm -$ 4 PLC $\pm -$ ANGLES $\pm 5^\circ$		CHK PRAKASH.S 16-Sep-08	Tyco Electronics Corporation Dorcan, Swindon, SN3 5HH			
		APVD STEPHEN.P 16-Sep-08				
		PRODUCT SPEC -	NAME HIGH POWER RESISTORS SERIES C10			
		APPLICATION SPEC -	SIZE A 4	CAGE CODE 00779	DRAWING NO C= 1623773	RESTRICTED TO -
		WEIGHT -	CUSTOMER DRAWING			
			SCALE 2:1	SHEET 1	OF 1	REV BA1