

LOC	DIST	REVISIONS					
E	B	P	LTR	DESCRIPTION	DATE	DWN	APVD
			A	NEW RELEASE			17-SEP-09

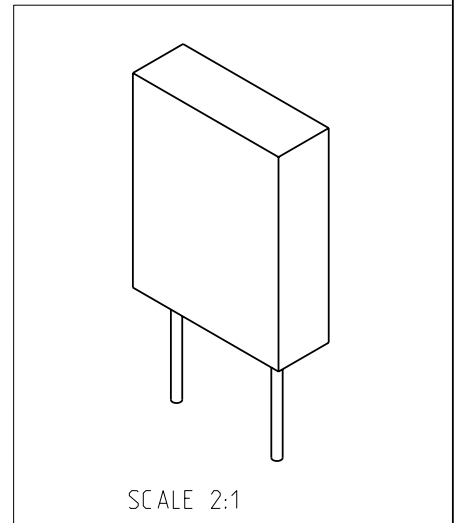
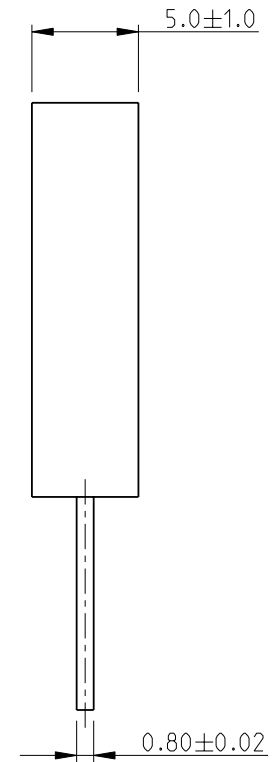
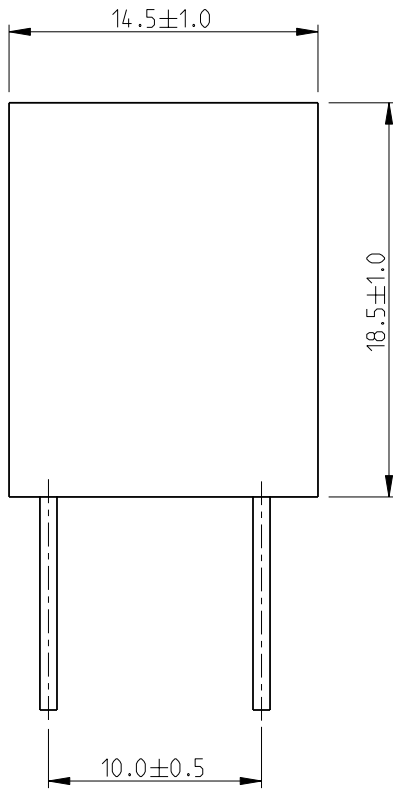

2009

RELEASED FOR PUBLICATION

THIS DRAWING IS UNPUBLISHED.

© COPYRIGHT 2009 BY TYCO ELECTRONICS CORPORATION. ALL RIGHTS RESERVED.

DIMENSIONS: mm	DWN	MAHARUDRA	17-SEP-09	MATERIAL	-	FINISH	-
	CHK	ALLAN.P	17-SEP-09	Tyco Electronics Corporation Dorcan, Swindon, SN3 5HH			
TOLERANCES UNLESS OTHERWISE SPECIFIED:	APVD	STEPHEN.P	17-SEP-09				
0 PLC ±0.2	PRODUCT SPEC	-	NAME	LOW OHM SHUNT HPR 5R(S)			
1 PLC ±0.1	APPLICATION SPEC	-	SIZE	CAGE CODE	DRAWING NO	RESTRICTED TO	
2 PLC ±-	WEIGHT	-	A 4	00779	©=1625811	-	
3 PLC ±-			CUSTOMER DRAWING				
4 PLC ±-			SCALE	3:1	SHEET	1 OF 1	REV
ANGLES ±5°							A