

Fixed Metal (Oxide) Film Resistors, Surface Mount Type

Type: **ERG(X)1H (1 W)**
ERG(X)2H (2 W)



■ **Features**

- Non-flammable
- High Reliability

■ **Packaging Methods**

Please see Pages 40 to 43

■ **Recommended Land Pattern**

Please see Pages 44 to 45

■ **Recommended Soldering Conditions**

Please see Page 46

■ **Safety Precautions**

Please see Page 47

■ **Explanation of Part Numbers**

Ex.1 : ERX type

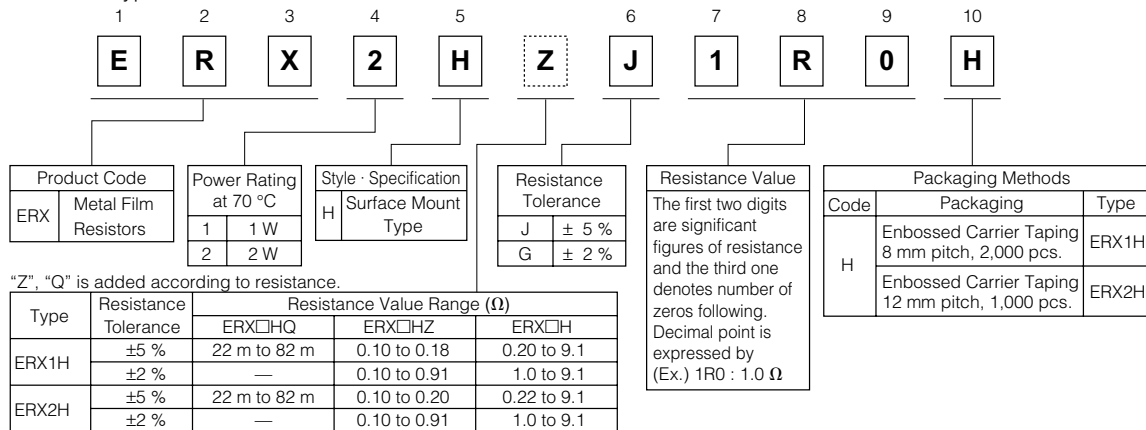

The above example 1 shows a metal film resistor SMD type, 2 W power rating, resistance value of 1.0 Ω, tolerance ±5 %, and embossed taping.

Ex.2 : ERG type

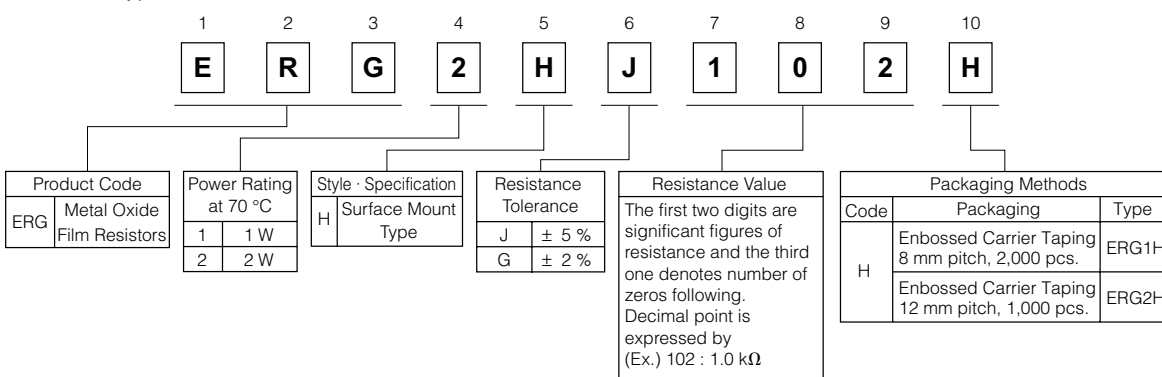

The above example 2 shows a metal oxide film resistor SMD type, 2 W power rating, resistance value of 1.0 kΩ, tolerance ±5 %, and embossed taping.

Construction

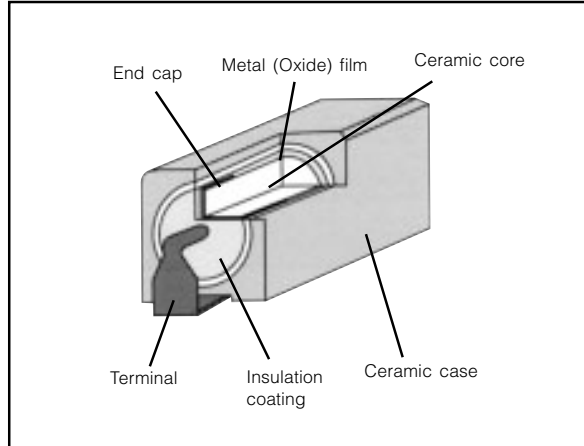

Dimensions in mm (not to scale)

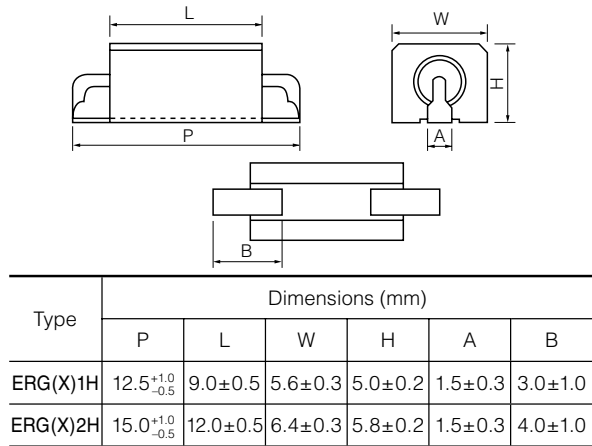

Ratings

Type	Power Rating at 70 °C (W) ⁽¹⁾	Dielectric Withstanding Voltage (VAC)	Res. Tol. (%) ⁽²⁾	Resistance Range (Ω) ⁽²⁾		T.C.R. (×10 ⁻⁶ /°C)	Standard Resistance Value
				min. ⁽³⁾	max.		
ERG(X)1H	1	1000	J (±5)	22 m	39 m	±1000	E12
			G (±2)	47 m	82 m	±500	
			J (±5)	0.1	10 k	±350	
ERG(X)2H	2	1000	J (±5)	22 m	39 m	±1000	E12
			G (±2)	47 m	82 m	±500	
			J (±5)	0.1	10 k	±350	

(1) Rated Continuous Working Voltage (RCWV) shall be determined from $RCWV = \sqrt{\text{Power Rating} \times \text{Resistance Value}}$.

(2) Resistance tolerance and resistance range is of use besides range listed, please inquire.

(3) As for the low resistance value range, "Q" or "Z" is given to the part number. (Refer to the explanation of part numbers.)

Power Derating Curve

For resistors operated in ambient temperatures above 70 °C, power rating shall be derated in accordance with the figure on the right.

