

5V VERY LOW DROP VOLTAGE REGULATOR

- 5V ± 4% PRECISE OUTPUT VOLTAGE OVER FULL TEMPERATURE RANGE (-40 / 125 °C)
- VERY LOW VOLTAGE DROP (0.75Vmax) OVER FULL TEMPERATURE RANGE
- OUTPUT CURRENT UP TO 500mA
- OVERVOLTAGE AND REVERSE VOLTAGE PROTECTIONS
- REVERSE VOLTAGE PROTECTION
- SHORT CIRCUIT PROTECTION AND THERMAL SHUT-DOWN (with hysteresis)
- LOW START UP CURRENT

DESCRIPTION

The L4945 is a monolithic integrated circuit in Versawatt package specially designed to provide a stabilized supply voltage for automotive and industrial electronic systems. Thanks to their very low voltage drop, in automotive applications the devices can work correctly even during the crank-

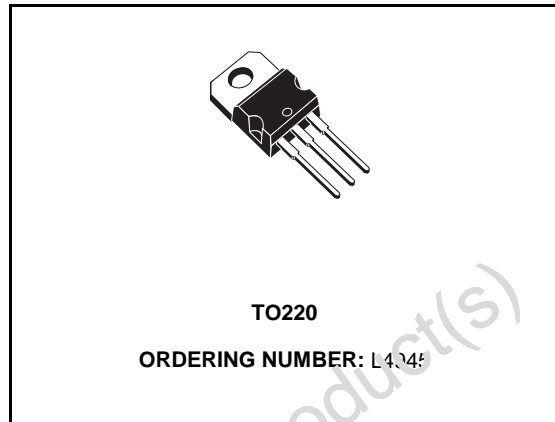

ing phase, when the battery voltage could fall as low as 6V. Furthermore, they incorporate a complete range of protection circuits against the dangerous overvoltages always present on the battery rail of the car.

BLOCK DIAGRAM

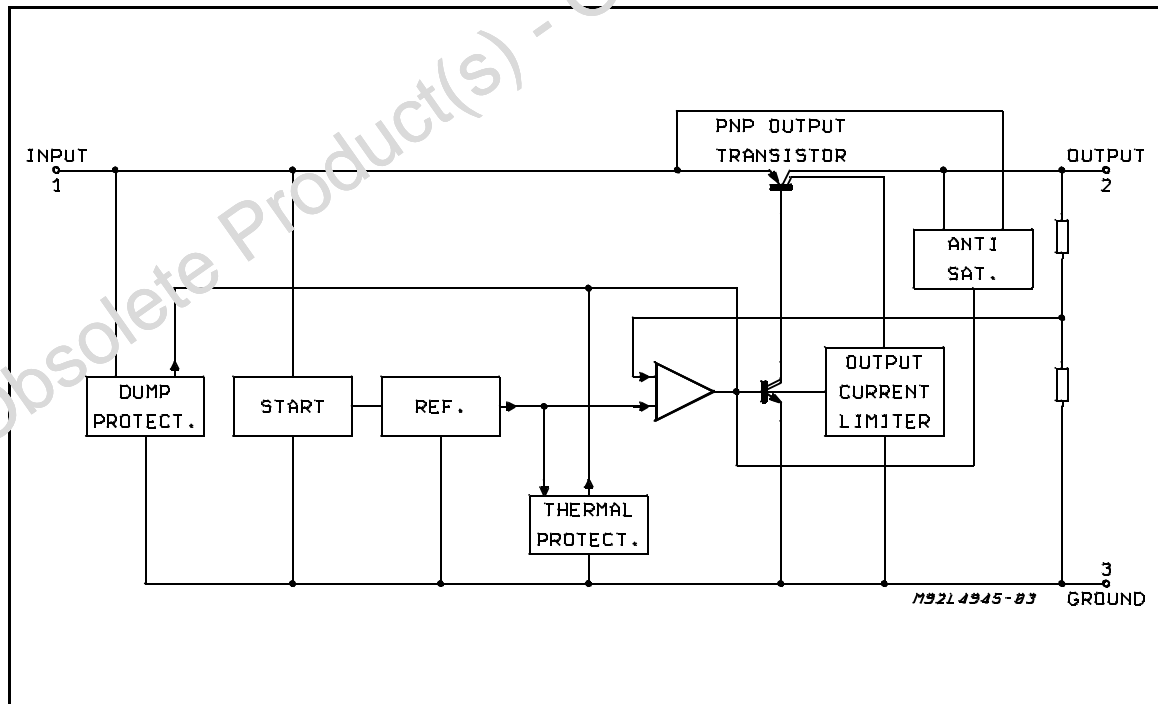

ABSOLUTE MAXIMUM RATINGS

Symbol	Parameter	Value	Unit
V _i	DC Input Voltage	35	V
	DC Reverse Input Voltage	- 18	V
	Transient Input Overvoltages :	80	V
	Load Dump :		
	5ms ≤ t _{rise} ≤ 10ms		
	τ _f Fall Time Constant = 100ms		
	R _{SOURCE} ≥ 0.5Ω	- 80	V
	Field Decay :		
	5ms ≤ t _{fall} ≤ 10ms, R _{SOURCE} ≥ 10Ω		
	τ _r Rise Time Constant = 33ms	± 100	V
	Low Energy Spike :		
	t _{rise} = 1μs, t _{fall} = 500μs, R _{SOURCE} ≥ 10Ω		
	f _r Repetition Frequency = 5Hz		
T _J	Junction Temperature Range	- 40 to 150	°C
T _{OP}	Operating Temperature Range	- 40 to 125	°C
T _{stg}	Storage Temperature Range	- 55 to 150	°C

Note: The circuit is ESD protected according to MIL-STD-883C.

PIN CONNECTION (Top view)

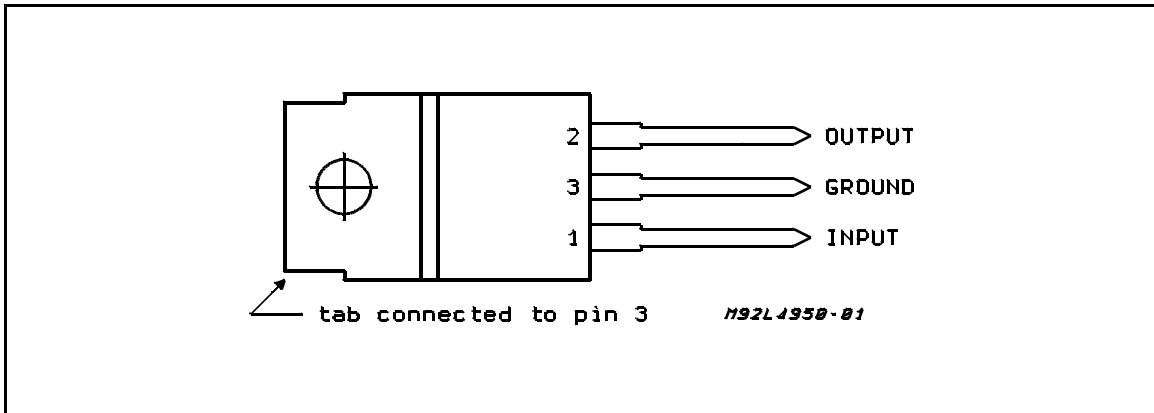

THERMAL DATA

Symbol	Parameter	Value	Unit
R _{th j-case}	Thermal Resistance Junction-case	Max 3	°C/W

TEST CIRCUIT

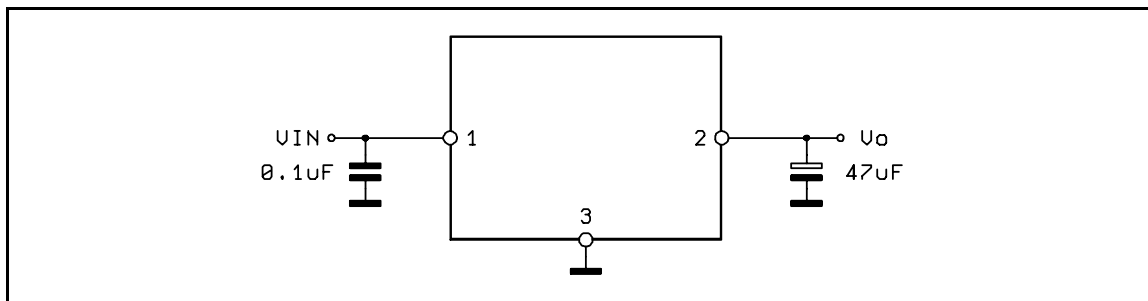

ELECTRICAL CHARACTERISTICS (refer to the test circuit, $V_i = 14.4\text{V}$, $C_o = 47\mu\text{F}$, $\text{ESR} < 10\Omega$, $R_p = 1\text{K}\Omega$, $R_L = 1\text{K}\Omega$, $-40^\circ\text{C} \leq T_J \leq 125^\circ\text{C}$, unless otherwise specified)

Symbol	Parameter	Test Conditions	Min.	Typ.	Max.	Unit
V_o	Output Voltage	$I_o = 0\text{mA}$ to 500mA Over Full T Range	4.80	5.00	5.20	V
		$T_J = 25^\circ\text{C}$	4.90	5.00	5.10	V
V_i	Operating Input Voltage	$I_o = 0\text{mA}$ to (*) 500mA	6		26	V
ΔV_o	Line Regulation	$V_i = 6\text{V}$ to 26V ; $I_o = 5\text{mA}$		2	10	mV
ΔV_o	Load Regulation	$I_o = 5\text{mA}$ to 500mA		15	60	mV
$V_i - V_o$	Dropout Voltage	$I_o = 500\text{mA}$, $T_J = 25^\circ\text{C}$ Over Full T Range		0.40	0.55 0.75	V V
I_q	Quiescent Current	$I_o = 0\text{mA}$, $T_J = 25^\circ\text{C}$		5	10	mA
		$I_o = 0\text{mA}$ Over Full T		6.5	13	mA
		$I_o = 500\text{mA}$ Over Full T		110	180	mA
$\frac{\Delta V_o}{T}$	Temperature Output Voltage Drift			-0.5		mV/°C
SVR	Supply Volt. Rej.	$I_o = 350\text{mA}$; $f = 120\text{Hz}$ $C_o = 100\mu\text{F}$; $V_i = 12\text{V} \pm 5V_{pp}$	50	60		dB
I_{sc}	Output Short Circuit Current		0.50	0.80	1.50	A

(*) For a DC voltage $26 < V_i < 37\text{V}$ the device is not operating

FUNCTIONAL DESCRIPTION

The block diagram shows the basic structure of the devices : the reference, the error amplifier, the driver, the power PNP, the protection and reset functions.

The power stage is a Lateral PNP transistor which allows a very low dropout voltage (typ. 400mV at $T_J = 25^\circ\text{C}$, max. 750mV over the full temperature range @ $I_o = 500\text{mA}$). The typical curve of the dropout voltage as a function of the junction temperature is shown in Fig. 1 : that is the worst case, where $I_o = 500\text{mA}$.

The current consumption of the devices (quiescent current) are maximum 10mA - over full T -

when no load current is required.

The internal antisaturation circuit allows a drastic reduction in the current peak which takes place during the start up.

The three gain stages (operational amplifier, driver and power PNP) require the external capacitor ($C_{omin} = 20\mu\text{F}$) to guarantee the global stability of the system.

Load dump and field decay protections ($\pm 80\text{V}$, $t = 300\text{ms}$), reverse voltage (-18V) and short circuit protection, thermal shutdown are the main features that make the devices specially suitable for applications in the automotive environment.



Figure 1: Typical Dropout Voltage vs. T_j
($I_o = 500\text{mA}$).

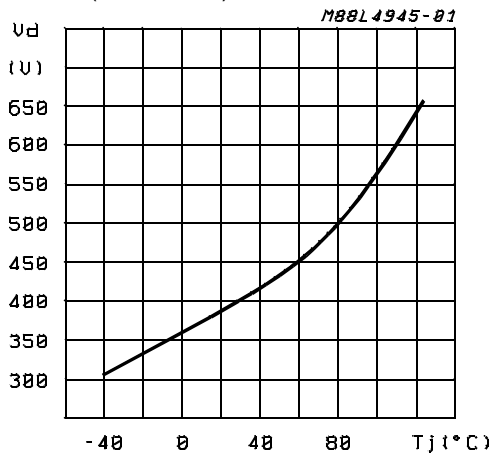

EXTERNAL COMPENSATION

Since the purpose of a voltage regulator is to supply and load variations, the open loop gain of the regulators must be very high at low frequencies. This may cause instability as a result of the vari-

ous poles present in the loop. To avoid this instability dominant pole compensation is used to reduce phase shift due to other poles at the unity gain frequency. The lower the frequency of these other poles at the unity gain frequency. The lower the frequency of these other poles, the greater must be capacitor used to create the dominant pole for the same DC gain.

Where the output transistor is a lateral PNP type there is a pole in the regulation loop at a frequency too low to be compensated by a capacitor which can be integrated. An external compensation is therefore necessary so a very high value capacitor must be connected from the output to ground.

The parasitic equivalent series resistance of the capacitor used adds a zero to the regulation loop. This zero may compromise the stability of the system since its effect tends to cancel the effect of the pole added. In regulators this ESR must be less than 3Ω and the minimum capacitor value is $47\mu\text{F}$.

DIM.	mm			inch		
	MIN.	TYP.	MAX.	MIN.	TYP.	MAX.
A	4.40		4.60	0.173		0.181
C	1.23		1.32	0.048		0.051
D	2.40		2.72	0.094		0.107
E	0.49		0.70	0.019		0.027
F	0.61		0.88	0.024		0.034
F1	1.14		1.70	0.044		0.067
F2	1.14		1.70	0.044		0.067
G	4.95		5.15	0.194		0.203
G1	2.40		2.70	0.094		0.106
H2	10.0		10.4	0.393		0.409
L2		16.4			0.645	
L4	13.0		14.0	0.511		0.551
L5	2.65		2.95	0.104		0.116
L6	15.25		15.75	0.600		0.620
L7	6.20		6.60	0.244		0.260
L9	3.50		3.93	0.137		0.154
M		2.6			0.102	
Dia	3.75		3.85	0.147		0.151

OUTLINE AND MECHANICAL DATA

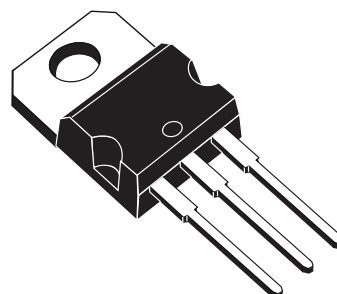

Versawatt (TO220)

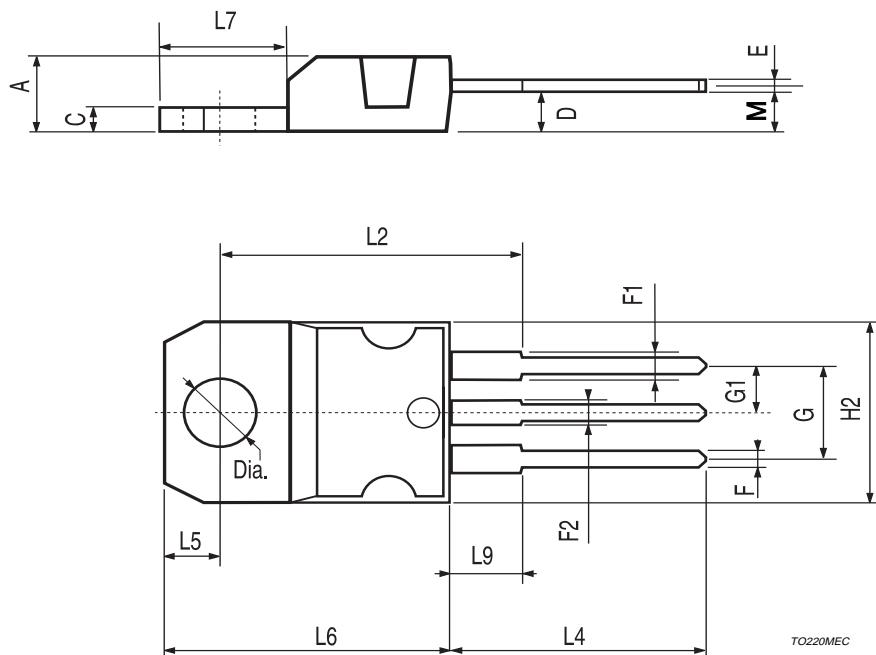

Information furnished is believed to be accurate and reliable. However, STMicroelectronics assumes no responsibility for the consequences of use of such information nor for any infringement of patents or other rights of third parties which may result from its use. No license is granted by implication or otherwise under any patent or patent rights of STMicroelectronics. Specification mentioned in this publication are subject to change without notice. This publication supersedes and replaces all information previously supplied. STMicroelectronics products are not authorized for use as critical components in life support devices or systems without express written approval of STMicroelectronics.

The ST logo is a registered trademark of STMicroelectronics

© 1999 STMicroelectronics – Printed in Italy – All Rights Reserved

STMicroelectronics GROUP OF COMPANIES

Australia - Brazil - Canada - China - France - Germany - Italy - Japan - Korea - Malaysia - Malta - Mexico - Morocco - The Netherlands - Singapore - Spain - Sweden - Switzerland - Taiwan - Thailand - United Kingdom - U.S.A.

<http://www.st.com>