

FEATURES

- *Guaranteed* 1% Initial Voltage Tolerance
- *Guaranteed* 3A Output Current
- *Guaranteed* 0.3% Load Regulation
- *Guaranteed* 0.01%/V Line Regulation
- 100% Thermal Limit Burn-in

APPLICATIONS

- Improved Linear Regulators
- Adjustable Power Supplies
- Constant Current Regulation
- Battery Chargers

DESCRIPTION

The LT150A Series are 3-terminal positive adjustable voltage regulators which offer improved performance over earlier devices. A major feature of the LT150A/350A is the output voltage tolerance is guaranteed at a maximum of $\pm 1\%$, allowing an overall power supply tolerance to be better than 3% using inexpensive 1% resistors. Line and load regulation performance has been improved as well. Additionally, the LT150A/350A reference voltage is guaranteed not to exceed 2% when operating over the full load, line and power dissipation conditions. The LT150A/350A adjustable regulators offer an improved solution for all positive voltage regulator requirements with load currents up to 3 amps.

Regulator With Reference

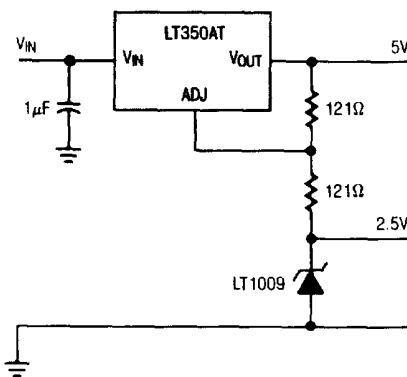

Output Voltage Error

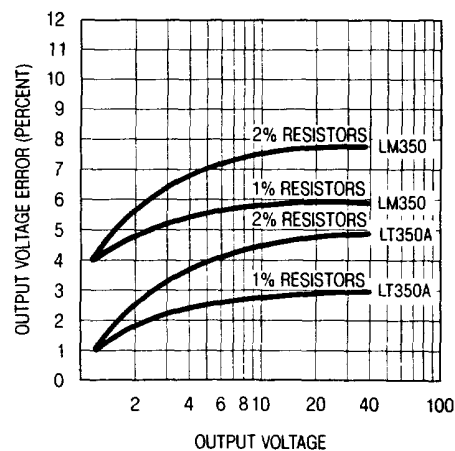

ABSOLUTE MAXIMUM RATINGS

Power Dissipation Internally Limited
 Input to Output Voltage Differential 35V
 Operating Junction Temperature Range
 LT150A/LM150 -55°C to 150°C
 LT350A/LM350 0°C to 125°C
 Storage Temperature Range
 LT150A/LM150 -65°C to 150°C
 LT350A/LM350 -65°C to 150°C
 Lead Temperature (Soldering, 10 sec.) 300°C

PRECONDITIONING:

100% THERMAL LIMIT BURN-IN

PACKAGE/ORDER INFORMATION

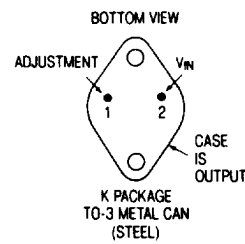

BOTTOM VIEW
ADJUSTMENT
1 2
VIN
CASE IS OUTPUT
K PACKAGE
TO-3 METAL CAN
(STEEL)

ORDER PART NUMBER

LT150AK
LT350AK
LM150K
LM350K

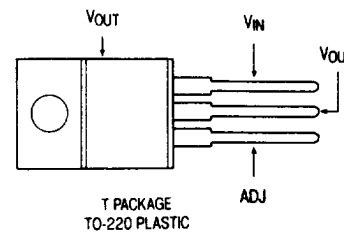

VOUT
VIN
VOUT
ADJ
T PACKAGE
TO-220 PLASTIC

LT350AT
LM350T

ELECTRICAL CHARACTERISTICS (See Note 1)

SYMBOL	PARAMETER	CONDITIONS	LT150A			LM150			UNITS
			MIN	TYP	MAX	MIN	TYP	MAX	
V _{REF}	Reference Voltage	I _{OUT} = 10mA, T _J = 25°C	1.238	1.250	1.262				V
		3V ≤ (V _{IN} - V _{OUT}) ≤ 35V 10mA ≤ I _{OUT} ≤ 3A, P ≤ 30W	●	1.225	1.250	1.270	1.20	1.25	1.30
ΔV _{OUT} /ΔV _{IN}	Line Regulation	3V ≤ (V _{IN} - V _{OUT}) ≤ 35V, (See Note 2)		0.005	0.01		0.005	0.01	%/V
			●		0.02	0.05		0.02	0.05
ΔV _{OUT} /ΔI _{OUT}	Load Regulation	10mA ≤ I _{OUT} ≤ 3A, (See Note 2) T _A = 25°C V _{OUT} ≤ 5V V _{OUT} ≥ 5V		5	15		5	15	mV
				0.1	0.3		0.1	0.3	%
		●		15	50		20	50	mV
		●		0.3	1		0.3	1	%
	Thermal Regulation	T _A = 25°C, 20msec Pulse		0.002	0.01		0.002	0.01	%/W
	Ripple Rejection	V _{OUT} = 10V, f = 120Hz C _{ADJ} = 0 C _{ADJ} = 10μF	●	66	65		66	65	dB
			●	66	86		66	86	dB
I _{ADJ}	Adjust Pin Current		●	50	100		50	100	μA
ΔI _{ADJ}	Adjust Pin Current Change	10mA ≤ I _L ≤ 3A 3V ≤ (V _{IN} - V _{OUT}) ≤ 35V	●	0.2	5		0.2	5	μA
	Minimum Load Current	(V _{IN} - V _{OUT}) = 35V	●	3.5	5		3.5	5	mA
	Current Limit	(V _{IN} - V _{OUT}) ≤ 10V	●	3	4.5		3.0	4.5	A
		(V _{IN} - V _{OUT}) = 30V	●	0.3	1		0.3	1	A
ΔV _{OUT} /ΔTemp	Temperature Stability	-55°C ≤ T _J ≤ +150°C	●		1	2		1	%
ΔV _{OUT} /ΔTime	Long Term Stability	T _A = 125°C		0.3	1		0.3	1	%
e _n	RMS Output Noise (% of V _{OUT})	T _A = 25°C, 10Hz ≤ f ≤ 10kHz		0.001			0.001		%
θ _{JC}	Thermal Resistance Junction to Case	K Package			1.5			1.5	°C/W

ELECTRICAL CHARACTERISTICS (See Note 1)

SYMBOL	PARAMETER	CONDITIONS	LT350A			LM350			UNITS
			MIN	TYP	MAX	MIN	TYP	MAX	
V_{REF}	Reference Voltage	$I_{OUT} = 10mA, T_j = 25^\circ C$	1.238	1.250	1.262				V
		$3V \leq (V_{IN} - V_{OUT}) \leq 35V$ $10mA \leq I_{OUT} \leq 3A, P \leq 30W$	● 1.225	1.250	1.270	1.20	1.25	1.30	V
$\frac{\Delta V_{OUT}}{\Delta V_{IN}}$	Line Regulation	$3V \leq (V_{IN} - V_{OUT}) \leq 35V$, (See Note 2) $T_A = 25^\circ C$		0.005	0.01		0.005	0.03	%/V
			●	0.02	0.05		0.02	0.07	%/V
$\frac{\Delta V_{OUT}}{\Delta I_{OUT}}$	Load Regulation	$10mA \leq I_{OUT} \leq 3A$, (See Note 2) $T_A = 25^\circ C$ $V_{OUT} \leq 5V$ $V_{OUT} \geq 5V$		5	15		5	25	mV
			●	0.1	0.3		0.1	0.5	%
			●	15	50		20	70	mV
		$V_{OUT} \geq 5V$	●	0.3	1		0.3	1.5	%
	Thermal Regulation	$T_A = 25^\circ C, 20msec$ Pulse		0.002	0.01		0.002	0.03	%/W
	Ripple Rejection	$V_{OUT} = 10V, f = 120Hz$ $C_{ADJ} = 0$ $C_{ADJ} = 10\mu F$	●	65			65		dB
●			66	86		66	86		dB
I_{ADJ}	Adjust Pin Current		●	50	100		50	100	μA
ΔI_{ADJ}	Adjust Pin Current Change	$10mA \leq I_{OUT} \leq 3A$ $3V \leq (V_{IN} - V_{OUT}) \leq 35V$	●	0.2	5		0.2	5	μA
	Minimum Load Current	$(V_{IN} - V_{OUT}) \leq 35V$	●	3.5	10		3.5	10	mA
	Current Limit	$(V_{IN} - V_{OUT}) \leq 10V$	●	3	4.5		3	4.5	A
		$(V_{IN} - V_{OUT}) = 30V, T_j = 25^\circ C$		0.25	1		0.25	1	A
$\frac{\Delta V_{OUT}}{\Delta Temp}$	Temperature Stability		●	1	2		1		%
$\frac{\Delta V_{OUT}}{\Delta Time}$	Long Term Stability	$T_A = 125^\circ C$		0.3	1		0.3	1	%
e_n	RMS Output Noise (% of V_{OUT})	$T_A = 25^\circ C, 10Hz \leq f \leq 10kHz$		0.001			0.001		%
θ_{jc}	Thermal Resistance Junction to Case	K Package		1.2	1.5		1.2	1.5	$^\circ C/W$
		T Package		3	4		3	4	$^\circ C/W$

4

The ● denotes the specifications which apply over the full operating temperature range.

Note 1: Unless otherwise specified, these specifications apply for $V_{IN} - V_{OUT} = 5V$ and $I_{OUT} = 1.5A$. These specifications are applicable for power dissipations up to 30W for the K package and up to 25W for the T package. Power dissipation is guaranteed at these values up to 15 Volts input-output differential. Above 15 Volts input-output differential power dissipation is limited by device internal protection circuitry.

Note 2: Regulation is measured at a constant T_j . Changes in output due to heating must be taken into account separately. Pulse testing with low duty cycle is used.

TYPICAL PERFORMANCE CHARACTERISTICS

Load Regulation

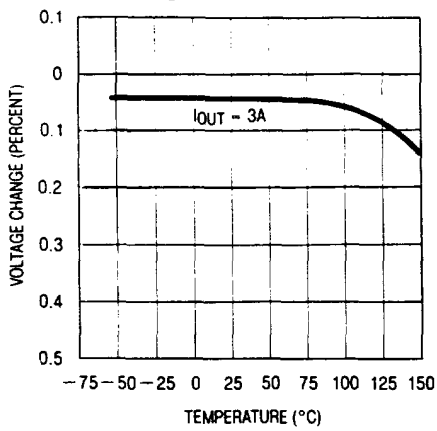

Current Limit

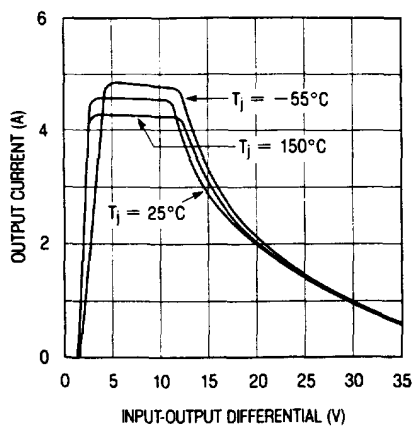

Adjustment Current

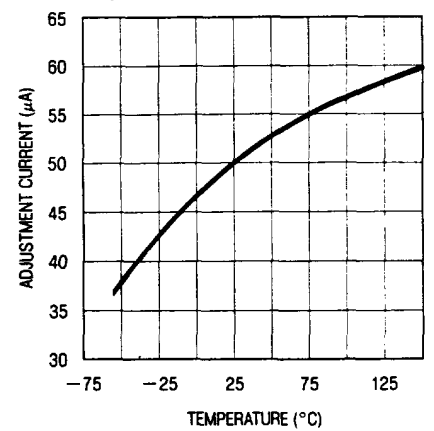

Dropout Voltage

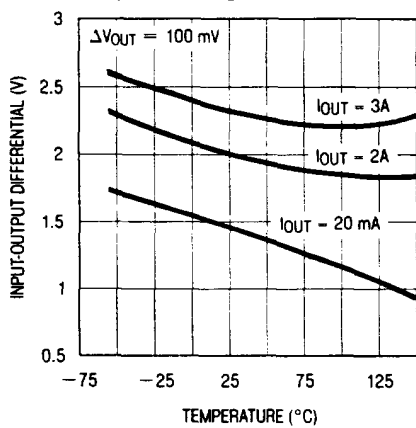

Temperature Stability

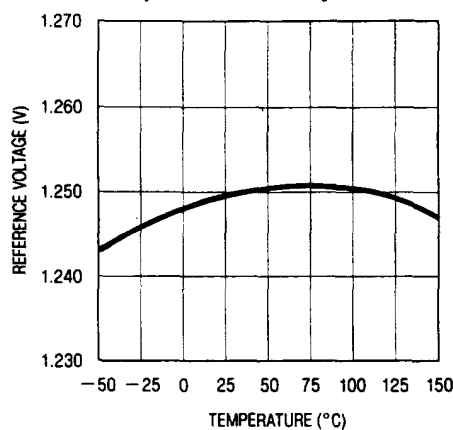

Minimum Operating Current

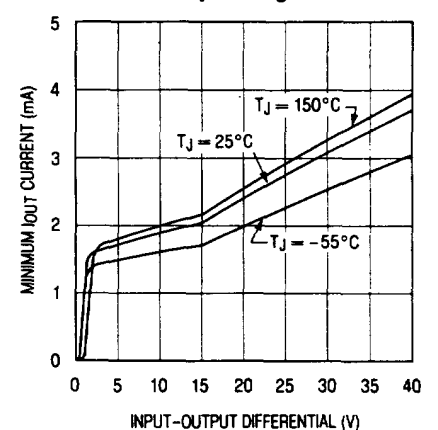

Ripple Rejection

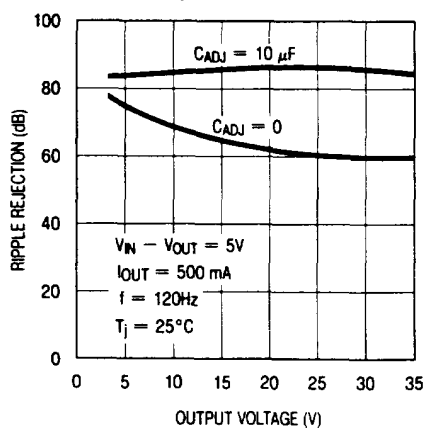

Ripple Rejection

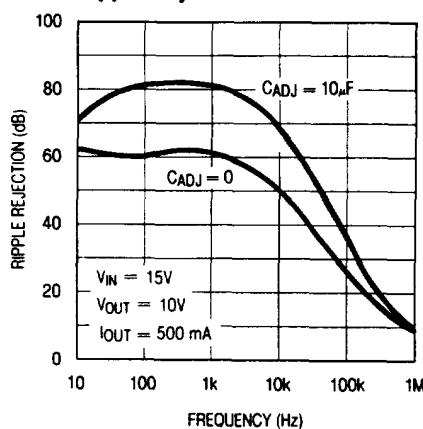

Ripple Rejection

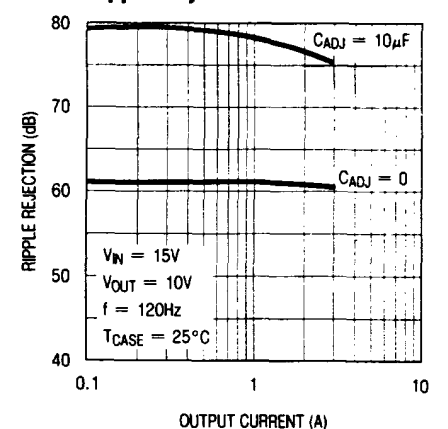

TYPICAL PERFORMANCE CHARACTERISTICS

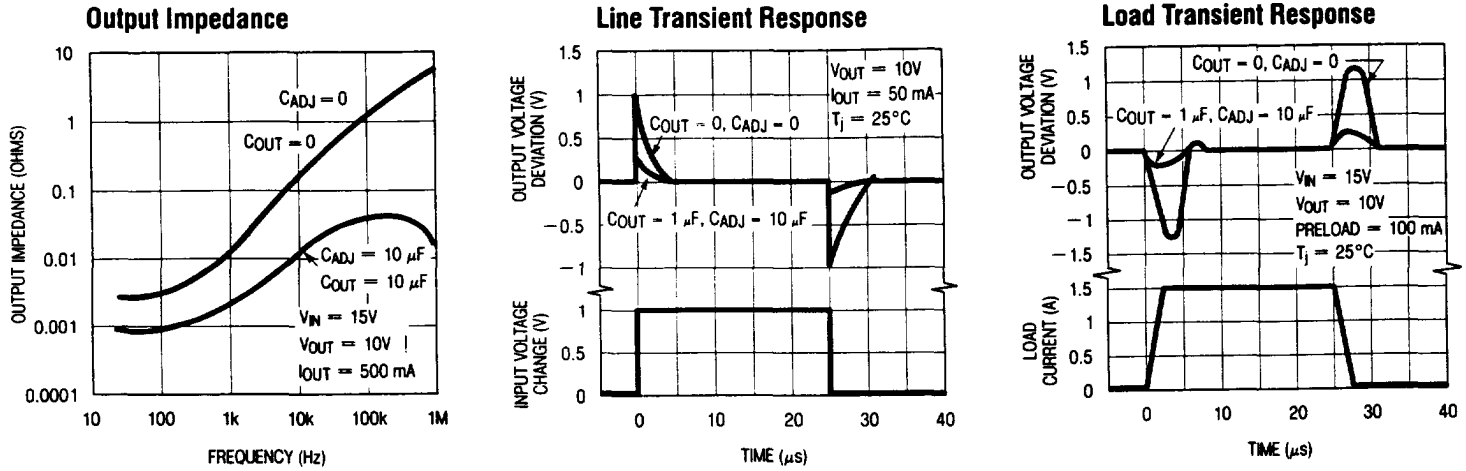

APPLICATION INFORMATION

General

The LT150A develops a 1.25V reference voltage between the output and the adjustable terminal (see Figure 1). By placing a resistor, R_1 , between these two terminals, a constant current is caused to flow through R_1 and down through R_2 to set the overall output voltage. Normally this current is the specified minimum load current of 5mA or 10mA.

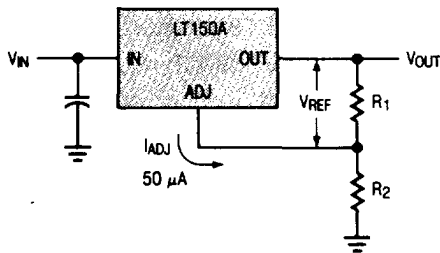

$$V_{OUT} = V_{REF} \left(1 + \frac{R_2}{R_1} \right) + I_{ADJ} R_2$$

Basic Adjustable Regulator
Figure 1

Because I_{ADJ} is very small and constant when compared with the current through R_1 , it represents a small error and can usually be ignored. It is easily seen from the above equation, that even if the resistors were of exact value, the accuracy of the output is limited by the accuracy of V_{REF} . Earlier adjustable regulators had a reference tolerance of $\pm 4\%$ which is

dangerously close to the $\pm 5\%$ supply tolerance required in many logic and analog systems. Further, even 1% resistors can drift $0.01\%/^\circ C$, adding additional error to the output voltage tolerance.

For example, using 2% resistors and $\pm 4\%$ tolerance for V_{REF} , calculations will show that the expected range of a 5V regulator design would be $4.66V \leq V_{OUT} \leq 5.36V$ or approximately $\pm 7\%$. If the same example were used for a 15V regulator, the expected tolerance would be $\pm 8\%$. With these results most applications required some method of trimming, usually a trim pot. This solution is both expensive and not conducive to volume production.

One of the enhancements of Linear Technology's adjustable regulators over existing devices is the tightened initial tolerance of V_{REF} . This allows relatively inexpensive 1% or 2% film resistors to be used for R_1 and R_2 to set the output voltage within an acceptable tolerance.

With a guaranteed 1% reference, a 5V power supply design, using $\pm 2\%$ resistors, would have a worst case manufacturing tolerance of $\pm 4\%$. If 1% resistors were used, the tolerance would drop to $\pm 2.5\%$. A plot of the worst case output voltage tolerance as a function of resistor tolerance is shown on the front page.

4

LT150A/LT350A LM150/LM350

For convenience, a table of standard 1% resistor values is shown below.

Table of 1/2% and 1% Standard Resistance Values

1.00	1.47	2.15	3.16	4.64	6.81
1.02	1.50	2.21	3.24	4.75	6.98
1.05	1.54	2.26	3.32	4.87	7.15
1.07	1.58	2.32	3.40	4.99	7.32
1.10	1.62	2.37	3.48	5.11	7.50
1.13	1.65	2.43	3.57	5.23	7.68
1.15	1.69	2.49	3.65	5.36	7.87
1.18	1.74	2.55	3.74	5.49	8.06
1.21	1.78	2.61	3.83	5.62	8.25
1.24	1.82	2.67	3.92	5.76	8.45
1.27	1.87	2.74	4.02	5.90	8.66
1.30	1.91	2.80	4.12	6.04	8.87
1.33	1.96	2.87	4.22	6.19	9.09
1.37	2.00	2.94	4.32	6.34	9.31
1.40	2.05	3.01	4.42	6.49	9.53
1.43	2.10	3.09	4.53	6.65	9.76

Standard Resistance Values are obtained from the Decade Table by multiplying by multiples of 10. As an example, 1.21 can represent 1.21Ω, 12.1Ω, 121Ω, 1.21KΩ etc.

Bypass Capacitors

Input bypassing using a 1μF tantalum or 25μF electrolytic is recommended when the input filter capacitors are more than 5 inches from the device. Improved ripple rejection (80 dB) can be accomplished by adding a 10μF capacitor from the adjust pin to ground. Increasing the size of the capacitor to 20μF will help ripple rejection at low output voltage since the reactance of this capacitor should be small compared to the voltage setting resistor, R2. For improved AC transient response and to prevent the possibility of oscillation due to unknown reactive load, a 1μF capacitor is also recommended at the output. Because of their low impedance at high frequencies, the best type of capacitor to use is solid tantalum.

Protection Diodes

The LT150A/350A do not require a protection diode from the adjustment terminal to the output (see Figure 2). Improved internal circuitry eliminates the need for this diode when the adjustment pin is bypassed with a capacitor to improve ripple rejection.

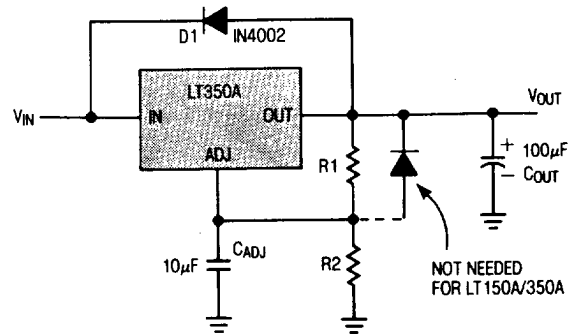

Figure 2

If a very large output capacitor is used, such as a 100μF shown in Figure 2, the regulator could be damaged or destroyed if the input is accidentally shorted to ground or crowbarred, due to the output capacitor discharging into the output terminal of the regulator. To prevent this, a diode D1 as shown, is recommended to safely discharge the capacitor.

Load Regulation

Because the LT150A is a three-terminal device, it is not possible to provide true remote load sensing. Load regulation will be limited by the resistance of the wire connecting the regulator to the load. The data sheet specification for load regulation is measured at the bottom of the package. Negative side sensing is a true Kelvin connection, with the bottom of the output divider returned to the negative side of the load. Although it may not be immediately obvious, best load regulation is obtained when the top of the resistor divider (R1) is connected *directly* to the case *not to the load*. This is illustrated in Figure 3. If R1 were connected to the load, the effective resistance between the regulator and the load would be

$$R_p \times \left(\frac{R_2 + R_1}{R_1} \right), R_p = \text{Parasitic Line Resistance.}$$

Connected as shown, R_p is not multiplied by the divider ratio. R_p is about 0.004Ω per foot using 16 gauge wire. This translates to 4mV/ft at 1A load current, so it

is important to keep the positive lead between regulator and load as short as possible, and use large wire or PC board traces.

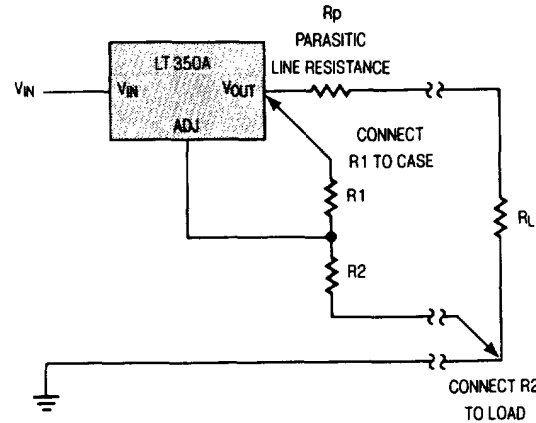

Connections for Best Load Regulation
Figure 3

TYPICAL APPLICATIONS

1.2V-25V Adjustable Regulator

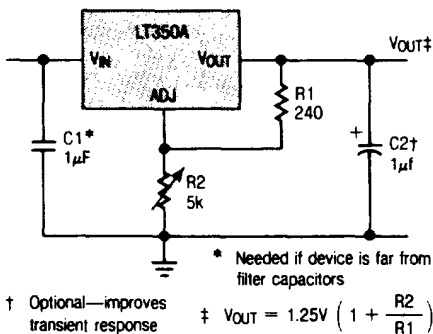

Improving Ripple Rejection

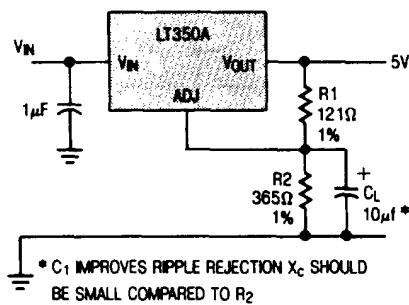

*Parallel Regulators for Higher Current

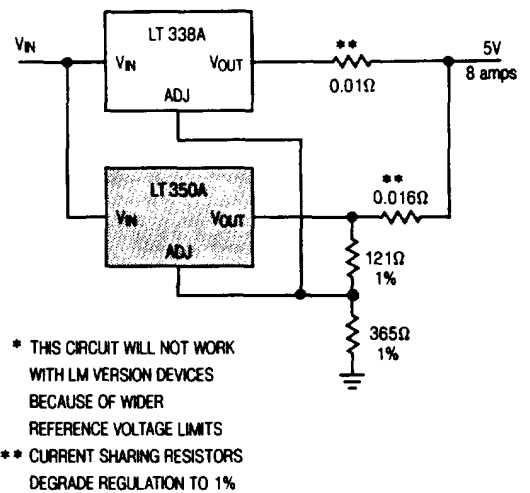

4

Adjustable Current Limiter

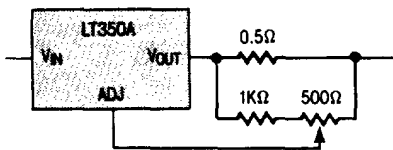

Automatic Light Control

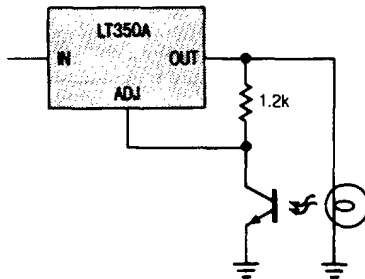

Precision High Current Reference

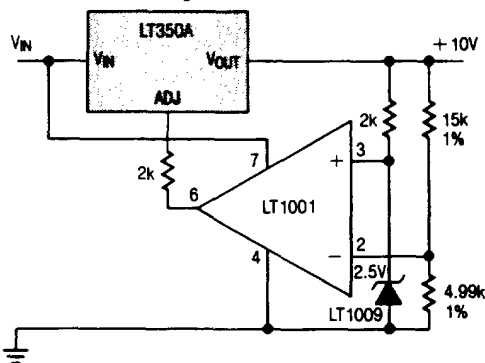

Remote Sensing

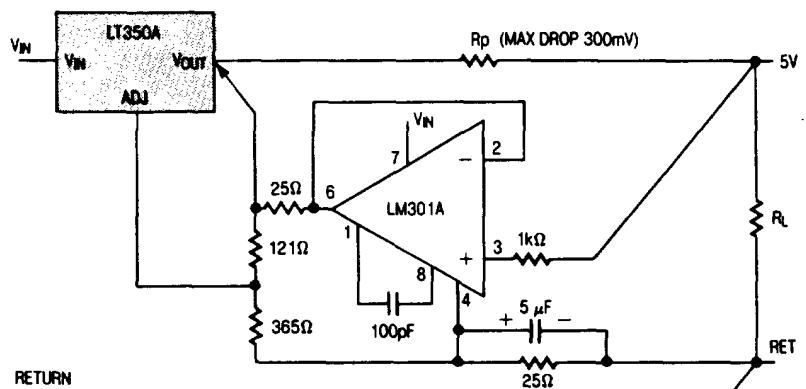

SCHEMATIC DIAGRAM

LT150A/LT350A

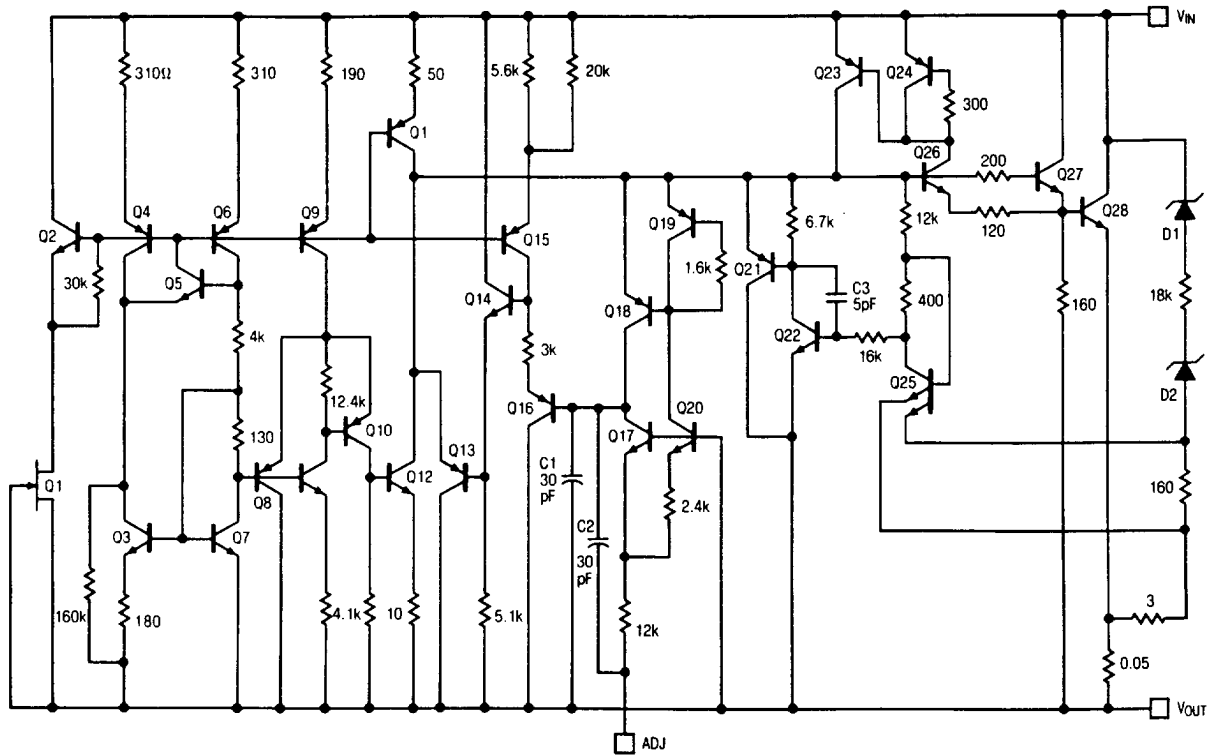

PACKAGE DESCRIPTION Dimensions in inches (millimeters) unless otherwise noted.

K Package TO-3 STEEL Metal Can

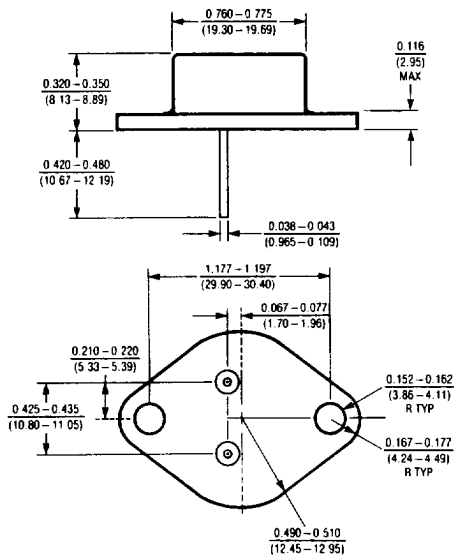

	T _j max.	θ _{ja}	θ _{jc}
LT150A LM150	150°C	35°C/W	1.5°C/W
LT350A LM350	125°C	35°C/W	1.5°C/W

T Package TO-220 Plastic

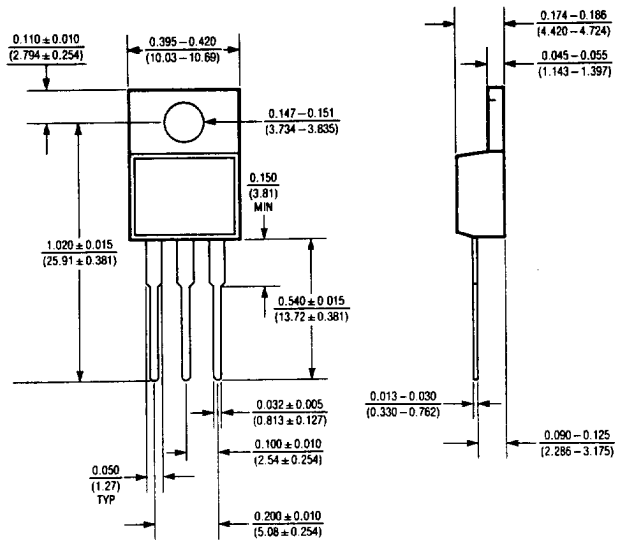

	T _j max.	θ _{ja}	θ _{jc}
LT350A LM350	125°C	50°C/W	2.5°C/W