

# High Voltage Positive Adjustable Regulators

## FEATURES

- 60V Operation
- *Guaranteed* 1% Output Voltage Tolerance
- *Guaranteed* max. 0.01%/V Line Regulation
- *Guaranteed* max. 0.3% Load Regulation
- Min. 1.5A Output Current
- 100% Burn-in in Thermal Overload

## APPLICATIONS

- Wide Range Power Supplies
- Constant Current Supplies
- Voltage Programmable Supplies

## DESCRIPTION

The LT117AHV Series are 3-terminal positive adjustable voltage regulators which offer improved performance over earlier devices. A major feature of the LT117AHV is the output voltage tolerance is guaranteed at a maximum of  $\pm 1\%$ , allowing an overall power supply tolerance to be better than 3% using inexpensive 1% resistors. Line and load regulation performance has been improved as well. Additionally, the LT117AHV reference voltage is guaranteed not to exceed 2% when operating over the full load, line and power dissipation conditions. The LT117AHV adjustable regulators offer an improved solution for all positive voltage regulator requirements with load currents up to 1.5 amps. For performance curves and applications circuits see the LT117A series data sheet.

4

Regulator with Reference

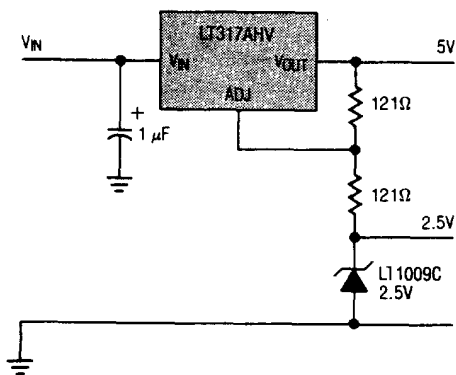

Output Voltage Error

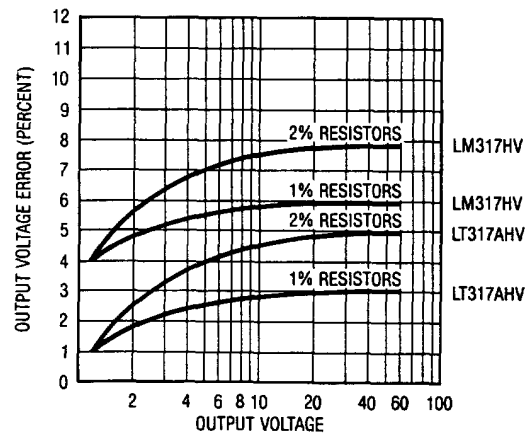

## ABSOLUTE MAXIMUM RATINGS

Power Dissipation	Internally Limited
Input to Output Voltage Differential	60V
Operating Junction Temperature Range	
LT117AHV/LM117HV	-55°C to 150°C
LT317AHV/LM317HV	0°C to 125°C
Storage Temperature Range	
LT117AHV/LM117HV	-65°C to 150°C
LT317AHV/LM317HV	-65°C to 150°C
Lead Temperature (Soldering, 10 sec.)	300°C

## PACKAGE/ORDER INFORMATION

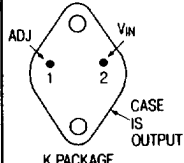
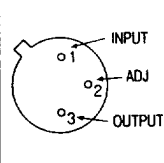
 <p>BOTTOM VIEW K PACKAGE TO-3 METAL CAN (STEEL)</p>	<p>ORDER PART NO.</p> <p>LT117AHVK LT317AHVK LM117HVK LM317HVK</p>	 <p>BOTTOM VIEW H PACKAGE TO-39 METAL CAN</p>	<p>ORDER PART NO.</p> <p>LT117AHVH LT317AHVH LM117HVH LM317HVH</p>
--	--	--	--

## PRECONDITIONING:

100% THERMAL LIMIT BURN-IN

## ELECTRICAL CHARACTERISTICS (See Note 1) LT117AHV/LM117HV

SYMBOL	PARAMETER	CONDITIONS	LT117AHV			LM117HV			UNITS
			MIN	TYP	MAX	MIN	TYP	MAX	
V <sub>REF</sub>	Reference Voltage	I <sub>OUT</sub> = 10mA, T <sub>J</sub> = 25°C	1.238	1.250	1.262				V
		3V ≤ (V <sub>IN</sub> - V <sub>OUT</sub> ) ≤ 60V 10mA ≤ I <sub>OUT</sub> ≤ I <sub>max</sub> , P ≤ P <sub>max</sub>	● 1.225	1.250	1.270	1.20	1.25	1.30	V
ΔV <sub>OUT</sub> /ΔV <sub>IN</sub>	Line Regulation	3V ≤ (V <sub>IN</sub> - V <sub>OUT</sub> ) ≤ 60V (See Note 2)	● 0.005 0.01			0.01	0.02	%/V	
			● 0.01 0.02			0.02	0.05	%/V	
ΔV <sub>OUT</sub> /ΔI <sub>OUT</sub>	Load Regulation	10mA ≤ I <sub>OUT</sub> ≤ I <sub>max</sub> , (See Note 2) V <sub>OUT</sub> ≤ 5V V <sub>OUT</sub> ≥ 5V	5	15		5	15	mV	
			0.1	0.3		0.1	0.3	%	
			● 20	50		20	50	mV	
		V <sub>OUT</sub> ≤ 5V V <sub>OUT</sub> ≥ 5V	● 0.3	1		0.3	1	%	
	Thermal Regulation	T <sub>A</sub> = 25°C, 20msec Pulse	● 0.002 0.02			0.03	0.07	%/W	
	Ripple Rejection	V <sub>OUT</sub> = 10V, f = 120Hz C <sub>ADJ</sub> = 0	● 65			65		dB	
		C <sub>ADJ</sub> = 10μF	● 66	80		66	80	dB	
I <sub>ADJ</sub>	Adjust Pin Current		● 50	100		50	100	μA	
ΔI <sub>ADJ</sub>	Adjust Pin Current Change	10mA ≤ I <sub>OUT</sub> ≤ I <sub>max</sub> 2.5V ≤ (V <sub>IN</sub> - V <sub>OUT</sub> ) ≤ 60V	● 0.2	5		0.2	5	μA	
I <sub>min</sub>	Minimum Load Current	(V <sub>IN</sub> - V <sub>OUT</sub> ) = 60V	● 3.5	7		3.5	7	mA	
	Current Limit	(V <sub>IN</sub> - V <sub>OUT</sub> ) ≤ 15V	● 1.5	2.2		1.5	2.2	A	
		K Package	● 0.5	0.8		0.5	0.8	A	
		(V <sub>IN</sub> - V <sub>OUT</sub> ) = 60V, T <sub>J</sub> = 25°C		0.1		0.1		A	
		K Package	0.03		0.03		A		
		H Package						A	
ΔV <sub>OUT</sub> /ΔTemp	Temperature Stability	-55°C ≤ T <sub>J</sub> ≤ +150°C	1 2			1		%	
ΔV <sub>OUT</sub> /ΔTime	Long Term Stability	T <sub>A</sub> = 125°C	0.3	1		0.3	1	%	
e <sub>n</sub>	RMS Output Noise (% of V <sub>OUT</sub> )	T <sub>A</sub> = 25°C, 10Hz ≤ f ≤ 10kHz	0.001			0.001			%
θ <sub>jc</sub>	Thermal Resistance Junction to Case	H Package	12	15		12	15	°C/W	
		K Package	2.3	3		2.3	3	°C/W	

**ELECTRICAL CHARACTERISTICS** (See Note 1) LT317AHV/LM317HV

SYMBOL	PARAMETER	CONDITIONS	LT317AHV			LM317HV			UNITS
			MIN	TYP	MAX	MIN	TYP	MAX	
V <sub>REF</sub>	Reference Voltage	I <sub>OUT</sub> = 10mA, T <sub>j</sub> = 25°C	1.238	1.250	1.262				V
		3V ≤ (V <sub>IN</sub> - V <sub>O</sub> ) ≤ 60V 10mA ≤ I <sub>OUT</sub> ≤ I <sub>max</sub> , P ≤ P <sub>max</sub>	● 1.225	1.250	1.270	1.20	1.25	1.30	V
$\frac{\Delta V_{OUT}}{\Delta V_{IN}}$	Line Regulation	3V ≤ (V <sub>IN</sub> - V <sub>OUT</sub> ) ≤ 60V (See Note 2)	● 0.005 0.01			0.01	0.04	%/V	
			● 0.01 0.02			0.02	0.07	%/V	
$\frac{\Delta V_{OUT}}{\Delta I_{OUT}}$	Load Regulation	10mA ≤ I <sub>OUT</sub> ≤ I <sub>max</sub> , (See Note 2) V <sub>O</sub> ≤ 5V V <sub>O</sub> ≥ 5V	5 25			5	25	mV	
			0.1 0.5			0.1	0.5	%	
		● 20 50			20	70	mV		
		● 0.3 1			0.3	1.5	%		
	Thermal Regulation	T <sub>A</sub> = 25°C, 20msec Pulse	0.002 0.02			0.04	0.07	%/W	
	Ripple Rejection	V <sub>O</sub> = 10V, f = 120Hz C <sub>ADJ</sub> = 0	● 65			65		dB	
		C <sub>ADJ</sub> = 10μF	● 66	80		66	80	dB	
I <sub>ADJ</sub>	Adjust Pin Current		● 50 100			50	100	μA	
ΔI <sub>ADJ</sub>	Adjust Pin Current Change	10mA ≤ I <sub>OUT</sub> ≤ I <sub>max</sub> 2.5V ≤ (V <sub>IN</sub> - V <sub>OUT</sub> ) ≤ 60V	● 0.2 5			0.2	5	μA	
I <sub>min</sub>	Minimum Load Current	(V <sub>IN</sub> - V <sub>OUT</sub> ) = 60V	● 3.5 12			3.5	12	mA	
		(V <sub>IN</sub> - V <sub>OUT</sub> ) ≤ 15V K Package H Package	● 1.5 2.2			1.5	2.2	A	
			● 0.5 0.8			0.5	0.8	A	
		(V <sub>IN</sub> - V <sub>OUT</sub> ) = 60V, T <sub>j</sub> = 25°C K Package H Package	0.1 0.03			0.1	0.03	A	
$\frac{\Delta V_{OUT}}{\Delta Temp}$	Temperature Stability	0°C ≤ T <sub>j</sub> ≤ 125°C	1 2			1	%		
$\frac{\Delta V_{OUT}}{\Delta Time}$	Long Term Stability	T <sub>A</sub> = 125°C	0.3 1			0.3	1	%	
e <sub>n</sub>	RMS Output Noise (% of V <sub>OUT</sub> )	T <sub>A</sub> = 25°C, 10Hz ≤ f ≤ 10kHz	0.001			0.001	%		
θ <sub>jc</sub>	Thermal Resistance Junction to Case	H Package	12 15			12	15	°C/W	
		K Package	2.3 3			2.3	3	°C/W	

4

The ● denotes the specifications which apply over the full operating temperature range.

The shaded electrical specifications indicate those parameters which have been improved or guaranteed test limits provided for the first time.

**Note 1:** Unless otherwise specified, these specifications apply for (V<sub>IN</sub> - V<sub>OUT</sub>) = 5V; and I<sub>OUT</sub> = 0.1A for the TO-39 and I<sub>OUT</sub> = 0.5A for the TO-3 package. Although power dissipation is internally limited, these specifications are applicable for power dissipations of 2W for the TO-39, and 20W for the TO-3. I<sub>MAX</sub> is 1.5A for the TO-3 package and 0.5A for the TO-39.

**Note 2:** Regulation is measured at constant junction temperature, using pulse testing with a low duty cycle. Changes in output voltage due to heating effects are covered under the specification for thermal regulation.

# SCHEMATIC DIAGRAM

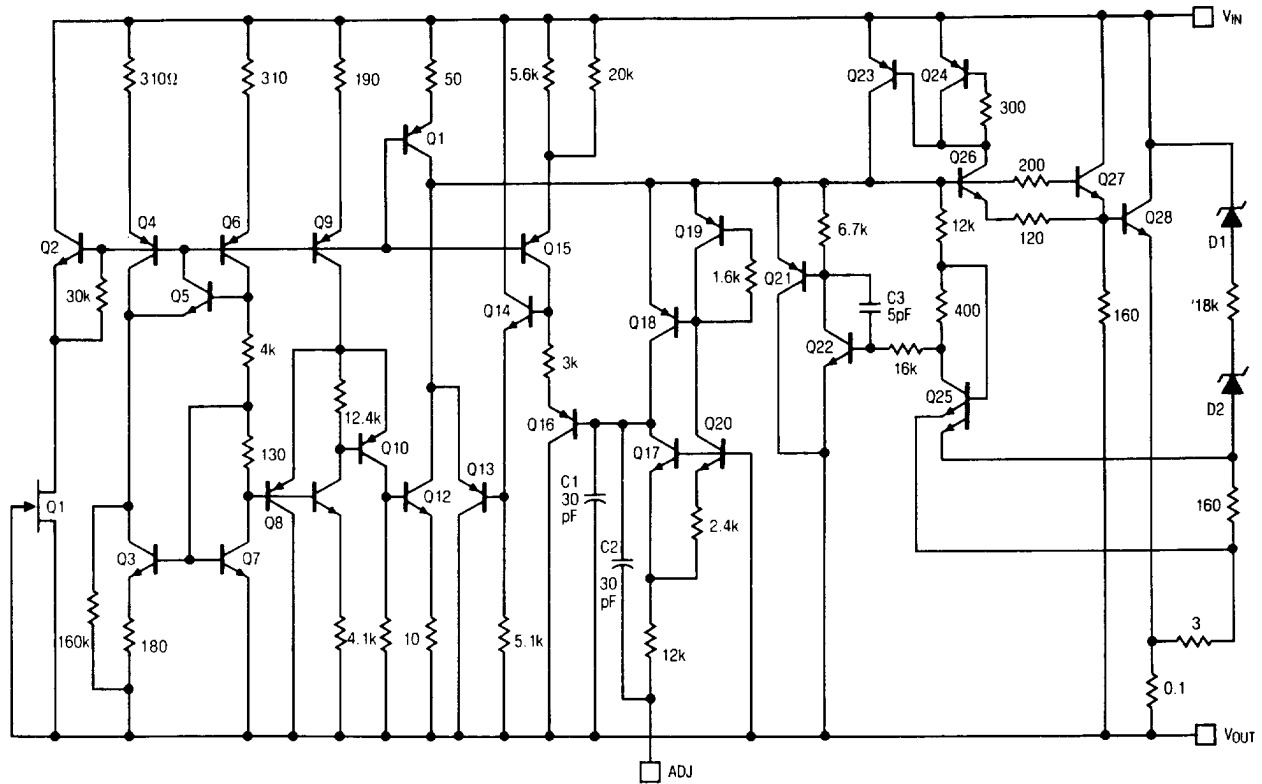

# PACKAGE DESCRIPTION

Dimensions in inches (millimeters) unless otherwise noted.

**K Package TO-3 STEEL Metal Can**

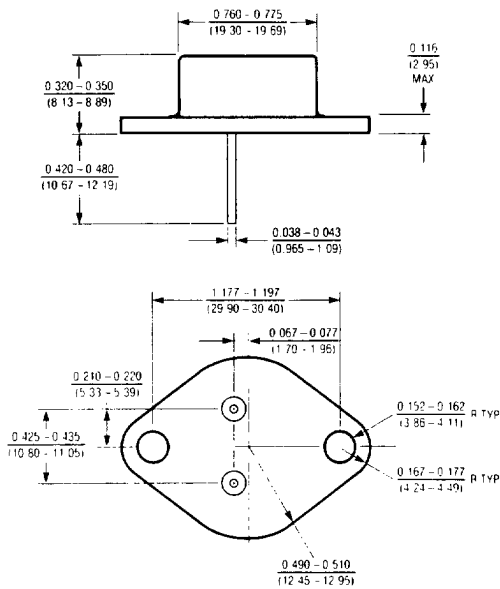

	T <sub>J</sub> max.	θ <sub>ja</sub>	θ <sub>jc</sub>
117AHV 117HV	150°C	35°C/W	3°C/W
317AHV 317HV	125°C	35°C/W	3°C/W

**H Package 3-Lead Metal Can**

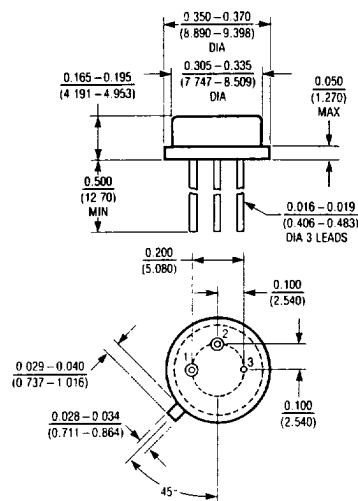

	T <sub>J</sub> max.	θ <sub>ja</sub>	θ <sub>jc</sub>
117AHV 117HV	150°C	150°C/W	15°C/W
317AHV 317HV	125°C	150°C/W	15°C/W