

CS8151

5.0 V, 100 mA Low Dropout Linear Regulator with Watchdog, RESET, and Wake Up

The CS8151 is a precision 5.0 V, 100 mA micro-power voltage regulator with very low quiescent current (400 μ A typical at 200 μ A load). The 5.0 V output is accurate within $\pm 2\%$ and supplies 100 mA of load current with a typical dropout voltage of 400 mV. Microprocessor control logic includes Watchdog, Wake Up and RESET. This unique combination of low quiescent current and full microprocessor control makes the CS8151 ideal for use in battery operated, microprocessor controlled equipment.

The CS8151 Wake Up function brings the microprocessor out of Sleep mode. The microprocessor in turn, signals its Wake Up status back to the CS8151 by issuing a Watchdog signal.

The Watchdog logic function monitors an input signal (WDI) from the microprocessor. The CS8151 responds to the falling edge of the Watchdog signal which it expects at least once during each wake-up period. When the correct Watchdog signal is received, a falling edge is issued on the wake-up signal line.

RESET is independent of V_{IN} and operates correctly to an output voltage as low as 1.0 V. A RESET signal is issued in any of three situations. During power up the RESET is held low until the output voltage is in regulation. During operation if the output voltage shifts below the regulation limits, the RESET toggles low and remains low until proper output voltage regulation is restored. And finally, a RESET signal is issued if the regulator does not receive a Watchdog signal within the Wake Up period.

The RESET pulse width, Wake Up signal frequency, and Wake Up delay time are all set by one external capacitor C_{Delay} .

The regulator is protected against short circuit, over voltage, and thermal runaway conditions. The device can withstand 74 V peak transients, making it suitable for use in automotive environments.

Features

- 5.0 V $\pm 2\%$ /100 mA Output Voltage
- Micropower Compatible Control Functions
 - ◆ Wake Up
 - ◆ Watchdog
 - ◆ RESET
- Low Dropout Voltage: 400 mV @ 100 mA
- Low Sleep Mode Quiescent Current (400 μ A Typ)
- Protection Features
 - ◆ Thermal Shutdown
 - ◆ Short Circuit
 - ◆ 74 V Peak Transient Capability
 - ◆ Reverse Transient (-50 V)
- Internally Fused Leads in SO-14L and SO-16L Packages
- These are Pb-Free Devices



ON Semiconductor®

<http://onsemi.com>

D²PAK-7
DPS SUFFIX
CASE 936AB

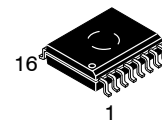
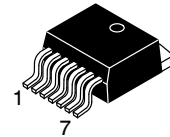

SO-16L
DWF SUFFIX
CASE 751G

SOIC-14
D SUFFIX
CASE 751A

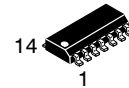

DEVICE MARKING INFORMATION

See general marking information in the device marking section on page 2 of this data sheet.

ORDERING INFORMATION

See detailed ordering and shipping information in the package dimensions section on page 11 of this data sheet.

CS8151

PIN CONNECTIONS AND MARKING DIAGRAMS

**D²PAK-7
CASE 936AB**

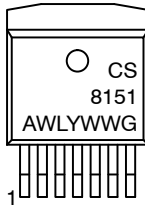

**SO-14L
CASE 751A**

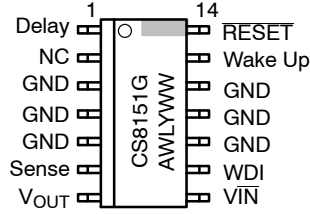

**SO-16L
CASE 751G**

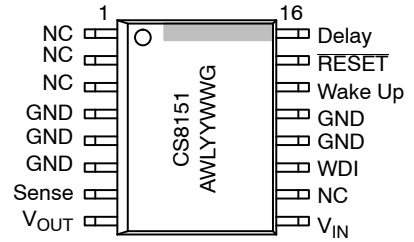

Tab = GND

- Pin 1. V_{OUT}
- 2. V_{IN}
- 3. WDI
- 4. GND
- 5. Wake Up
- 6. RESET
- 7. Delay

- A = Assembly Location
- WL = Wafer Lot
- Y, YY = Year
- WW = Work Week
- G = Pb-Free Package

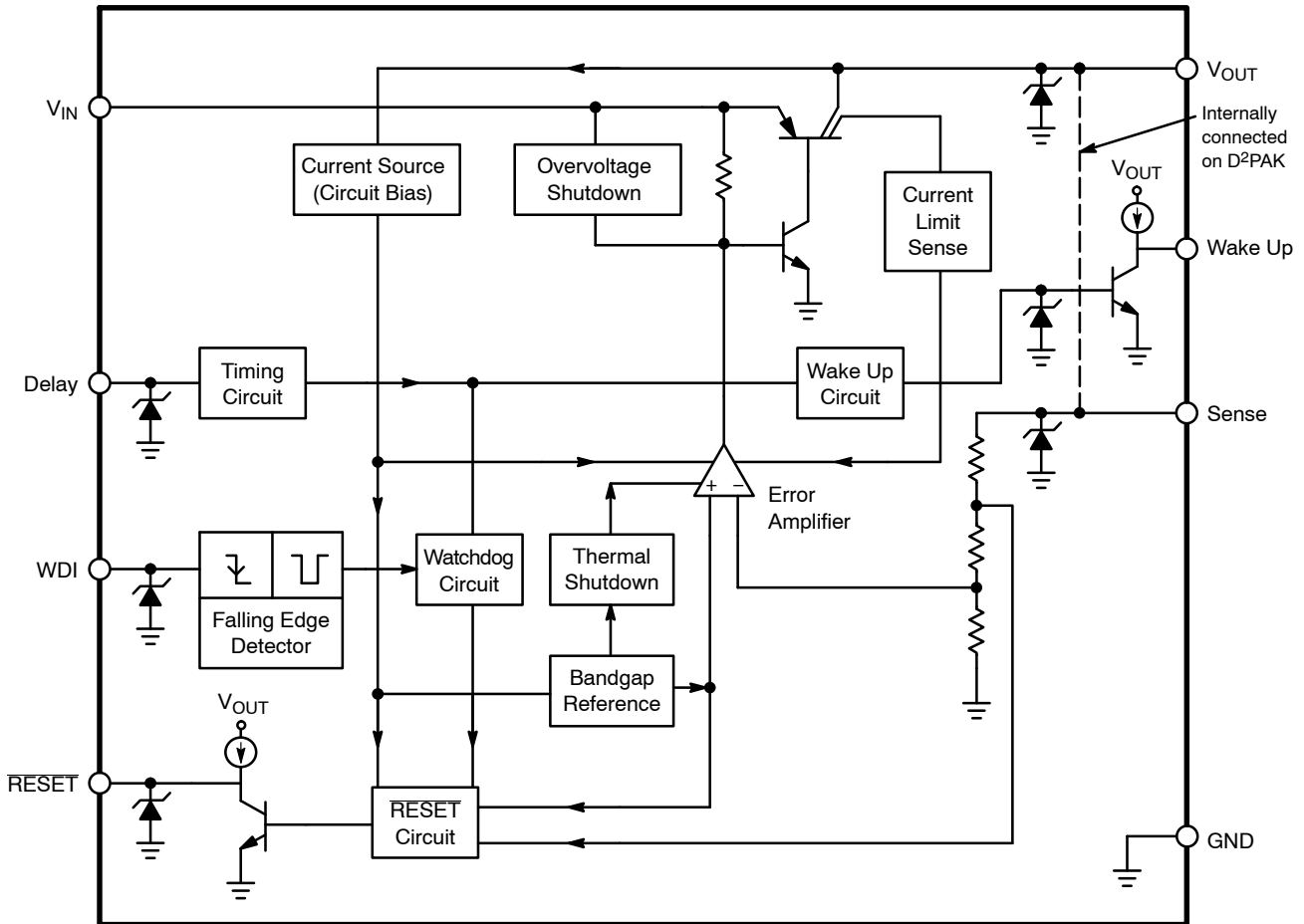

Figure 1. Block Diagram

CS8151

MAXIMUM RATINGS*

Rating	Value	Unit	
Power Dissipation	Internally Limited	–	
Output Current (V_{OUT} , RESET, Wake Up)	Internally Limited	–	
Reverse Battery	–15	V	
Peak Transient Voltage (60 V Load Dump @ $V_{IN} = 14$ V)	+74	V	
Maximum Negative Transient ($t < 2.0$ ms)	–50	V	
ESD Susceptibility (Human Body Model)	2.0	kV	
ESD Susceptibility (Machine Model)	200	V	
Logic Inputs/Outputs	–0.3 to +6.0	V	
Storage Temperature Range	–55 to +150	°C	
Lead Temperature Soldering	Wave Solder (through hole styles only) (Note 1) Reflow (SMD styles only) (Notes 2 & 3)	260 peak 240 peak	°C °C

Stresses exceeding Maximum Ratings may damage the device. Maximum Ratings are stress ratings only. Functional operation above the Recommended Operating Conditions is not implied. Extended exposure to stresses above the Recommended Operating Conditions may affect device reliability.

- 10 seconds max
- 60 seconds max above 183°C
- 5°C / +0°C allowable conditions

*The maximum package power dissipation must be observed

ELECTRICAL CHARACTERISTICS ($-40^{\circ}\text{C} \leq T_A \leq 125^{\circ}\text{C}$, $-40^{\circ}\text{C} \leq T_J \leq 150^{\circ}\text{C}$, $6.0\text{ V} \leq V_{IN} \leq 26\text{ V}$, $100\ \mu\text{A} \leq I_{OUT} \leq 100\text{ mA}$, $C_2 = 47\ \mu\text{F}$ (ESR $< 8.0\ \Omega$), $C_{Delay} = 0.1\ \mu\text{F}$; unless otherwise specified.)

Characteristic	Test Conditions	Min	Typ	Max	Unit
Output Section					
Output Voltage, V_{OUT}	$9.0\text{ V} < V_{IN} < 16\text{ V}$ $6.0\text{ V} < V_{IN} < 26\text{ V}$, $0 < I_{OUT} < 100\text{ mA}$	4.90 4.85	5.0 5.0	5.10 5.15	V V
Dropout Voltage ($V_{IN} - V_{OUT}$)	$I_{OUT} = 100\text{ mA}$ $I_{OUT} = 100\ \mu\text{A}$	– –	400 100	600 150	mV mV
Load Regulation	$V_{IN} = 14\text{ V}$, $100\ \mu\text{A} < I_{OUT} < 100\text{ mA}$	–	10	50	mV
Line Regulation	$I_{OUT} = 1.0\text{ mA}$, $6.0\text{ V} < V_{IN} < 26\text{ V}$	–	10	50	mV
Ripple Rejection	$7.0\text{ V} < V_{IN} < 17\text{ V}$ @ $f = 120\text{ Hz}$, $I_{OUT} = 100\text{ mA}$	60	75	–	dB
Current Limit	$V_{OUT} = 4.5\text{ V}$	100	250	–	mA
Thermal Shutdown	–	150	180	210	°C
Overvoltage Shutdown	$V_{OUT} < 1.0\text{ V}$	50	56	62	V
Quiescent Current	$I_{OUT} = 200\ \mu\text{A}$ (Sleep) $I_{OUT} = 50\text{ mA}$ $I_{OUT} = 100\text{ mA}$ (Wake Up)	– – –	0.4 4.0 12	0.75 – 20	mA mA mA
Reverse Current	$V_{OUT} = 5.0\text{ V}$, $V_{IN} = 0\text{ V}$	–	1.0	1.5	mA
RESET					
Threshold High (RTH)	RTH V_{OUT} Increasing	$V_{OUT} - 0.3$	–	$V_{OUT} - 0.04$	V
Threshold Low (RTL)	RTL V_{OUT} Decreasing	4.5	4.7	4.91	V
Hysteresis	RTH – RTL	150	200	250	mV
Output Low	$1.0\text{ V} < V_{OUT}$ RTL, $I_{OUT} = 25\ \mu\text{A}$	–	0.2	0.8	V
Output High	$I_{OUT} = 25\ \mu\text{A}$, $V_{OUT} > \text{RTH}$	3.8	4.2	5.1	V

CS8151

ELECTRICAL CHARACTERISTICS ($-40^{\circ}\text{C} \leq T_A \leq 125^{\circ}\text{C}$, $-40^{\circ}\text{C} \leq T_J \leq 150^{\circ}\text{C}$, $6.0\text{ V} \leq V_{\text{IN}} \leq 26\text{ V}$, $100\ \mu\text{A} \leq I_{\text{OUT}} \leq 100\text{ mA}$, $C_2 = 47\ \mu\text{F}$ (ESR < $8.0\ \Omega$), $C_{\text{Delay}} = 0.1\ \mu\text{F}$; unless otherwise specified.)

Characteristic	Test Conditions	Min	Typ	Max	Unit
RESET					
Current Limit	RESET = 0 V, $V_{\text{OUT}} > V_{\text{RTH}}$ (Sourcing) RESET = 5.0 V, $V_{\text{OUT}} > 1.0\text{ V}$ (Sinking)	0.025 0.1	0.5 12	1.30 80	mA mA
Delay Time	POR Mode	3.0	5.0	7.0	ms
Watchdog Input					
Threshold High	-	-	1.4	2.0	V
Threshold Low	-	0.8	1.3	-	V
Hysteresis	-	25	100	-	mV
Input Current	$0 < \text{WDI} < 6.0\text{ V}$	-10	0	+10	μA
Pulse Width	50% WDI Falling Edge to 50% WDI Rising Edge and 50% WDI Rising Edge to 50% WDI Falling Edge (see Figures 2, 3, and 4)	5.0	-	-	μs
Wake Up Output					
Wake Up Period	See Figure 2	30	40	50	ms
Wake Up Duty Cycle Nominal	See Figure 4	40	50	60	%
RESET High to Wake Up Rising Delay Time	50% RESET Rising Edge to 50% Wake Up Edge (see Figures 2, 3, and 4)	15	20	25	ms
Wake Up Response to Watchdog Input	50% WDI Falling Edge to 50% Wake Up Falling Edge	-	2.0	10	μs
Wake Up Response to RESET	50% RESET Falling Edge to 50% Wake Up Falling Edge, $V_{\text{OUT}} = 5.0\text{ V} \rightarrow 4.5\text{ V}$	-	2.0	10	μs
Output Low	$I_{\text{OUT}} = 25\ \mu\text{A}$ (Sinking)	-	0.2	0.8	V
Output High	$I_{\text{OUT}} = 25\ \mu\text{A}$ (Sourcing)	3.8	4.2	5.1	V
Current Limit	Wake Up = 5.0 V Wake Up = 0 V	0.025 0.05	1.0 -	7.0 3.5	mA mA

CS8151

PACKAGE PIN DESCRIPTION

Package Pin #			Pin Symbol	Function
SO-14L	D ² PAK	SO-16L		
7	1	8	V _{OUT}	Regulated output voltage 5.0 V ± 2%.
8	2	9	V _{IN}	Supply voltage to the IC.
9	3	11	WDI	CMOS/TTL compatible input lead. The Watchdog function monitors the falling edge of the incoming signal.
3-5, 10-12	4	4, 5, 6, 12, 13*	GND	Ground connection.
13	5	14	Wake Up	CMOS/TTL compatible output consisting of a continuously generated signal used to Wake Up the microprocessor from sleep mode.
14	6	15	RESET	CMOS/TTL compatible output lead RESET goes low whenever V _{OUT} drops by more than 6.0% from nominal, or during the absence of a correct watchdog signal.
1	7	16	Delay	Input lead from timing capacitor for RESET and Wake Up signal.
6	-	7	Sense	Kelvin connection which allows remote sensing of the output voltage for improved regulation. If remote sensing is not required, connect to V _{OUT} .

*Pin 6 GND is not directly shorted to the fused paddle GND. The fused paddle GND (pins 4, 5, 12, 13) is connected through the substrate. Pin 6 must be electrically connected to at least one of the fused paddle GND's on the PC board.

TIMING DIAGRAMS

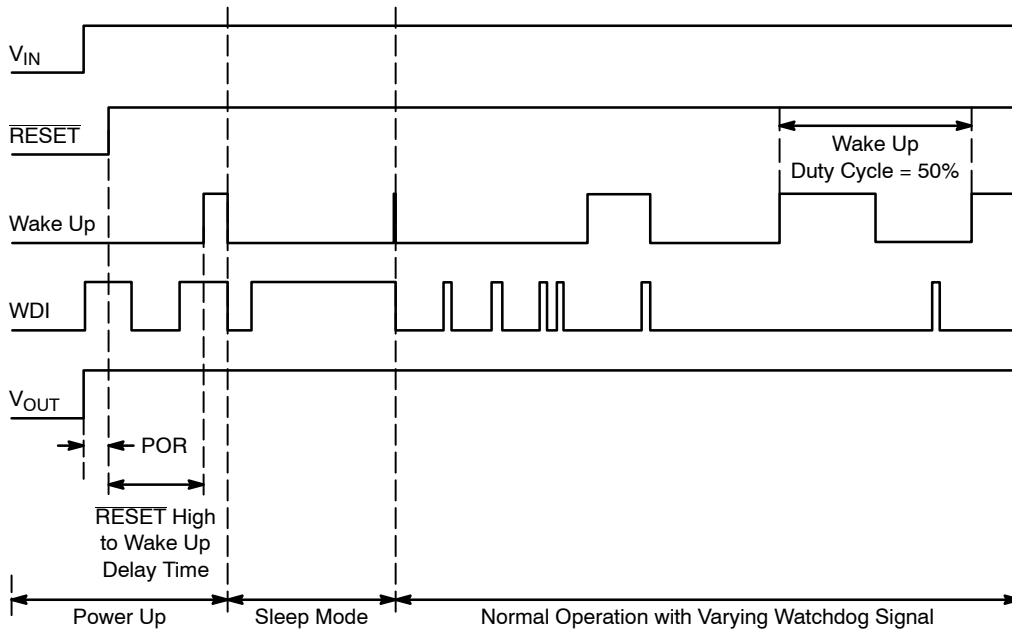

Figure 2. Power Up, Sleep Mode and Normal Operation

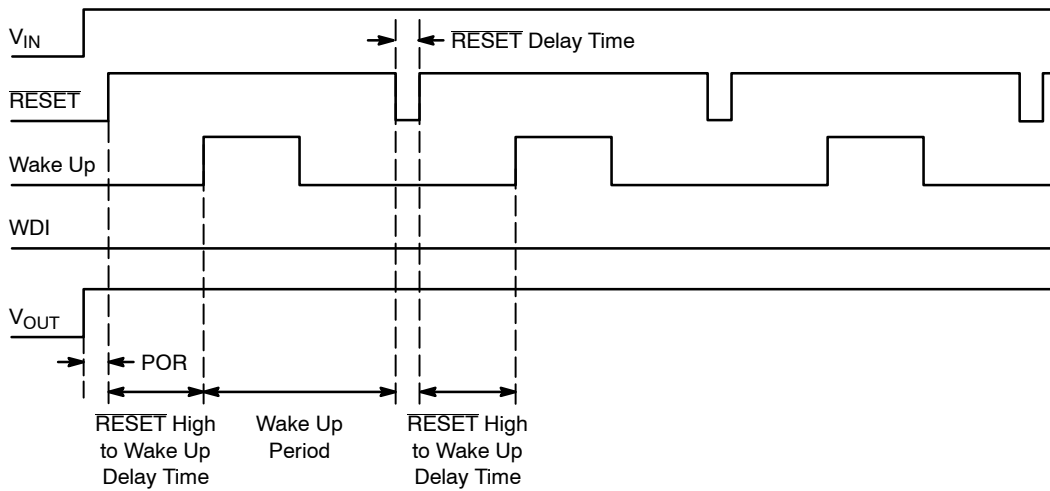

Figure 3. Error Condition: Watchdog Remains Low and a \overline{RESET} Is Issued

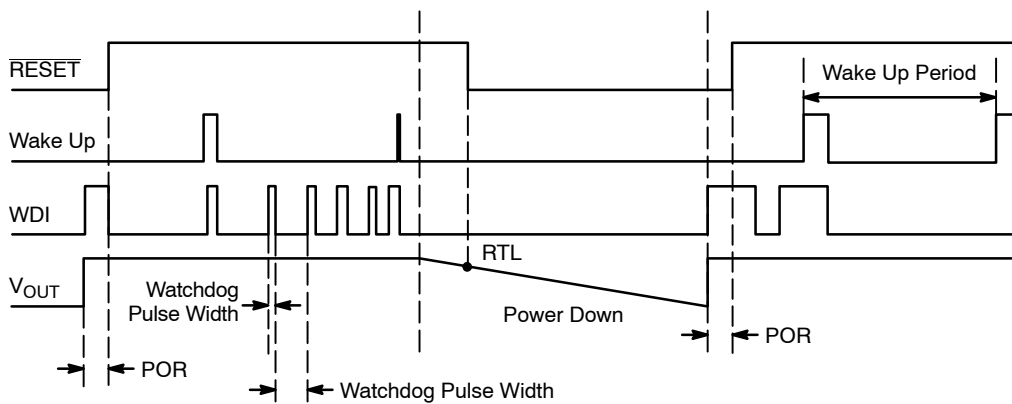

Figure 4. Power Down and Restart Sequence

DEFINITION OF TERMS

Dropout Voltage: The input–output voltage differential at which the circuit ceases to regulate against further reduction in input voltage. Measured when the output voltage has dropped 100mV from the nominal value obtained at 14V input, dropout voltage is dependent upon load current and junction temperature.

Input Voltage: The DC voltage applied to the input terminals with respect to ground.

Line Regulation: The change in output voltage for a change in the input voltage. The measurement is made under conditions of low dissipation or by using pulse

techniques such that the average chip temperature is not significantly affected.

Load Regulation: The change in output voltage for a change in load current at constant chip temperature.

Quiescent Current: The part of the positive input current that does not contribute to the positive load current. The regulator ground lead current.

Ripple Rejection: The ratio of the peak–to–peak input ripple voltage to the peak–to–peak output ripple voltage.

Current Limit: Peak current that can be delivered to the output.

CIRCUIT DESCRIPTION

Functional Description

To reduce the drain on the battery a system can go into a low current consumption mode when ever its not performing a main routine. The Wake Up signal is generated continuously and is used to interrupt a microcontroller that is in sleep mode. The nominal output is a 5.0 V square wave with a duty cycle of 50% at a frequency that is determined by a timing capacitor, C_{Delay} .

When the microprocessor receives a rising edge from the Wake Up output, it must issue a watchdog pulse and check its inputs to decide if it should resume normal operations or remain in the sleep mode.

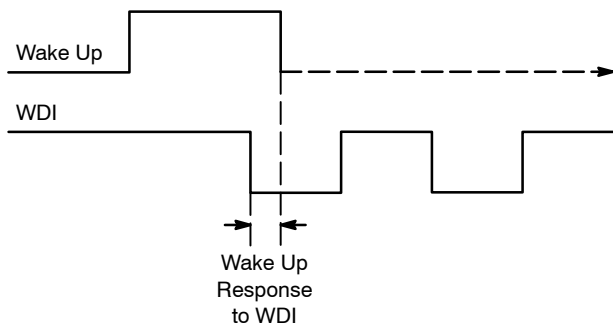

Figure 5. Wake Up Response to WDI

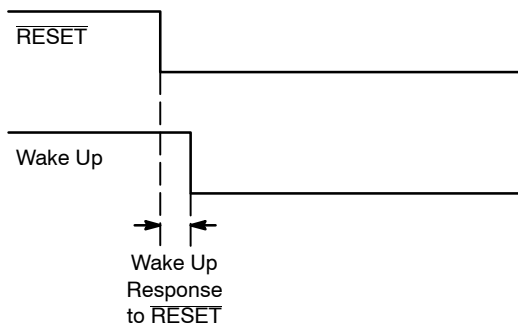

Figure 6. Wake Up Response to RESET (Low Voltage)

The first falling edge of the watchdog signal causes the Wake Up to go low within 2.0 μ s (Typ) and remain low until the next Wake Up cycle (see Figure 5). Other watchdog pulses received within the same cycle are ignored (Figures 2, 3, and 4).

During power up, $\overline{\text{RESET}}$ is held low until the output voltage is in regulation. During operation, if the output voltage shifts below the regulation limits, the $\overline{\text{RESET}}$ toggles low and remains low until proper output voltage regulation is restored. After the $\overline{\text{RESET}}$ delay, $\overline{\text{RESET}}$ returns high.

The Watchdog circuitry continuously monitors the input watchdog signal (WDI) from the microprocessor. The absence of a falling edge on the Watchdog input during one Wake Up cycle will cause a $\overline{\text{RESET}}$ pulse to occur at the end of the Wake Up cycle (see Figure 3).

The Wake Up output is pulled low during a $\overline{\text{RESET}}$ regardless of the cause of the $\overline{\text{RESET}}$. After the $\overline{\text{RESET}}$ returns high, the Wake Up cycle begins again (see Figure 3).

The $\overline{\text{RESET}}$ pulse width, Wake Up signal frequency and $\overline{\text{RESET}}$ high to Wake Up delay time are all set by one external capacitor C_{Delay} .

$$\text{Wake Up Period} = (4 \times 10^5)C_{Delay}$$

$$\overline{\text{RESET}} \text{ Delay Time} = (5 \times 10^4)C_{Delay}$$

$$\overline{\text{RESET}} \text{ High to Wake Up Delay Time} = (2 \times 10^5)C_{Delay}$$

Capacitor temperature coefficient and tolerance as well as the tolerance of the CS8151 must be taken into account in order to get the correct system tolerance for each parameter.

APPLICATION NOTES

Operation Without Watchdog

The CS8151 can be operated without the watchdog functionality by connecting the WDI and Wake Up Pins. This will eliminate false resets from occurring. Without the

connection, a reset would occur because a watchdog signal on WDI would not occur in the required time frame. The Wake Up Pin provides the watchdog signal into the WDI Pin.

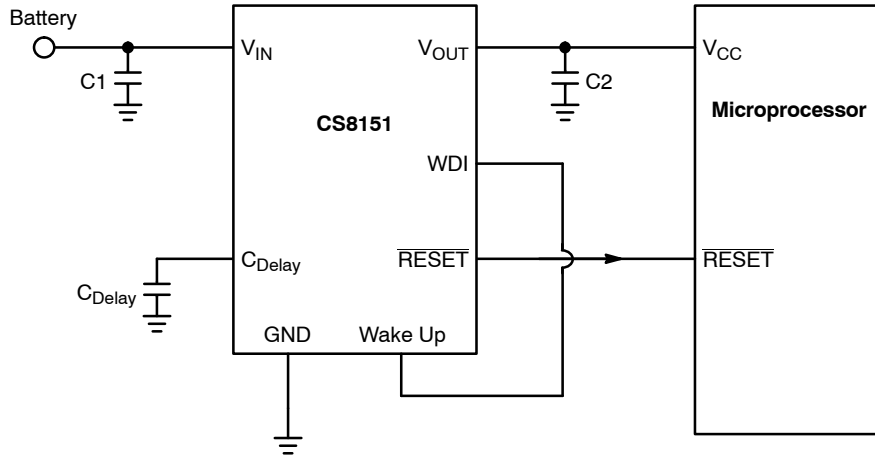

Figure 7. Device Operation Without Watchdog Function

Output Stage Protection

The output stage is protected against overvoltage, short circuit and thermal runaway conditions (see Figure 8).

If the input voltage rises above the overvoltage shutdown threshold (e.g. load dump), the output shuts down. This response protects the internal circuitry and enables the IC to survive unexpected voltage transients.

Should the junction temperature of the power device exceed 180°C (Typ) the power transistor is turned off. Thermal shutdown is an effective means to prevent die overheating since the power transistor is the principle heat source in the IC.

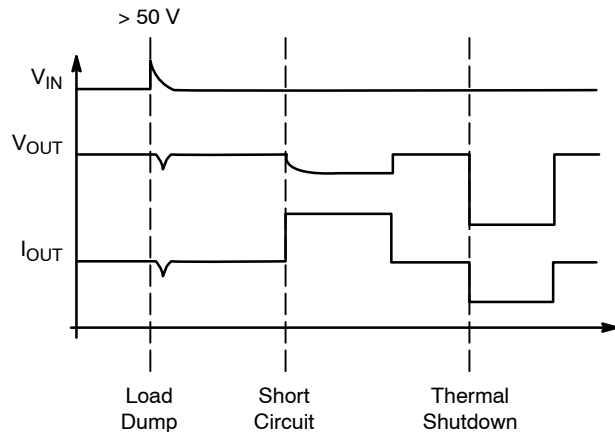
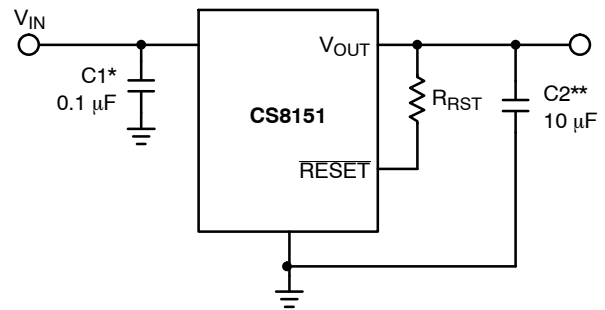

Figure 8. Typical Circuit Waveforms for Output Stage Protection

Stability Considerations

The output or compensation capacitor C2 (see Figure 9) helps determine three main characteristics of a linear regulator: startup delay, load transient response and loop stability.



*C1 required if regulator is located far from the power supply filter.

**C2 required for stability.

Figure 9. Test and Application Circuit Showing Output Compensation

The capacitor value and type should be based on cost, availability, size and temperature constraints. A tantalum or aluminum electrolytic capacitor is best, since a film or ceramic capacitor with almost zero ESR can cause instability. The aluminum electrolytic capacitor is the least expensive solution, but, if the circuit operates at low temperatures (-25°C to -40°C), both the value and ESR of

the capacitor will vary considerably. The capacitor manufacturers data sheet usually provide this information.

The value for the output capacitor C2 shown in the test and applications circuit should work for most applications, however it is not necessarily the optimized solution.

To determine an acceptable value for C2 for a particular application, start with a tantalum capacitor of the recommended value and work towards a less expensive alternative part.

Step 1: Place the completed circuit with a tantalum capacitor of the recommended value in an environmental chamber at the lowest specified operating temperature and monitor the outputs with an oscilloscope. A decade box connected in series with the capacitor will simulate the higher ESR of an aluminum capacitor. Leave the decade box outside the chamber, the small resistance added by the longer leads is negligible.

Step 2: With the input voltage at its maximum value, increase the load current slowly from zero to full load while observing the output for any oscillations. If no oscillations are observed, the capacitor is large enough to ensure a stable design under steady state conditions.

Step 3: Increase the ESR of the capacitor from zero using the decade box and vary the load current until oscillations appear. Record the values of load current and ESR that cause the greatest oscillation. This represents the worst case load conditions for the regulator at low temperature.

Step 4: Maintain the worst case load conditions set in step 3 and vary the input voltage until the oscillations increase. This point represents the worst case input voltage conditions.

Step 5: If the capacitor is adequate, repeat steps 3 and 4 with the next smaller valued capacitor. A smaller capacitor will usually cost less and occupy less board space. If the output oscillates within the range of expected operating conditions, repeat steps 3 and 4 with the next larger standard capacitor value.

Step 6: Test the load transient response by switching in various loads at several frequencies to simulate its real working environment. Vary the ESR to reduce ringing.

Step 7: Raise the temperature to the highest specified operating temperature. Vary the load current as instructed in step 5 to test for any oscillations.

Once the minimum capacitor value with the maximum ESR is found, a safety factor should be added to allow for the tolerance of the capacitor and any variations in regulator performance. Most good quality aluminum electrolytic capacitors have a tolerance of $\pm 20\%$ so the minimum value found should be increased by at least 50% to allow for this tolerance plus the variation which will occur at low temperatures. The ESR of the capacitor should be less than 50% of the maximum allowable ESR found in step 3 above.

Calculating Power Dissipation In a Single Output Linear Regulator

The maximum power dissipation for a single output regulator (Figure 10) is:

$$P_{D(max)} = (V_{IN(max)} - V_{OUT(min)})I_{OUT(max)} + V_{IN(max)}I_Q \quad (1)$$

where:

$V_{IN(max)}$ is the maximum input voltage,

$V_{OUT(min)}$ is the minimum output voltage,

$I_{OUT(max)}$ is the maximum output current for the application, and

I_Q is the quiescent current the regulator consumes at $I_{OUT(max)}$.

Once the value of $P_{D(max)}$ is known, the maximum permissible value of $R_{\theta JA}$ can be calculated:

$$R_{\theta JA} = \frac{150^\circ\text{C} - T_A}{P_D} \quad (2)$$

The value of $R_{\theta JA}$ can then be compared with those in the package section of the data sheet. Those packages with $R_{\theta JA}$'s less than the calculated value in equation 2 will keep the die temperature below 150°C.

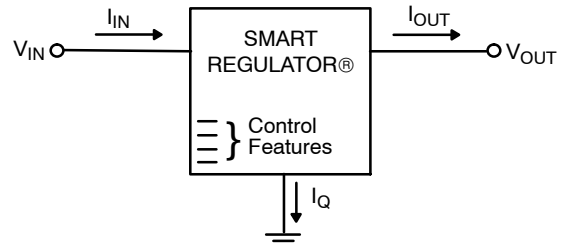

Figure 10. Single Output Regulator with Key Performance Parameters Labeled

In some cases, none of the packages will be sufficient to dissipate the heat generated by the IC, and an external heatsink will be required.

A heat sink effectively increases the surface area of the package to improve the flow of heat away from the IC and into the surrounding air.

Heat Sinks

Each material in the heat flow path between the IC and the outside environment will have a thermal resistance. Like series electrical resistances, these resistances are summed to determine the value of $R_{\theta JA}$:

$$R_{\theta JA} = R_{\theta JC} + R_{\theta CS} + R_{\theta SA} \quad (3)$$

where:

$R_{\theta JC}$ = the junction-to-case thermal resistance,

$R_{\theta CS}$ = the case-to-heatsink thermal resistance, and

$R_{\theta SA}$ = the heatsink-to-ambient thermal resistance.

$R_{\theta JC}$ appears in the package section of the data sheet. Like $R_{\theta JA}$, it too is a function of package type. $R_{\theta CS}$ and $R_{\theta SA}$ are functions of the package type, heatsink and the interface between them. These values appear in heatsink data sheets of heatsink manufacturers.

CS8151

PACKAGE THERMAL DATA

Parameter		D ² PAK-7	SOIC-14	SOIC-16	Unit
R _{θJC}	Typical	1.8	23**	18	°C/W
R _{θJA}	Typical	10-50*	116	75	°C/W

*Depending on thermal properties of substrate. $R_{\theta JA} = R_{\theta JC} + R_{\theta CA}$.

**Junction-Lead (#5)

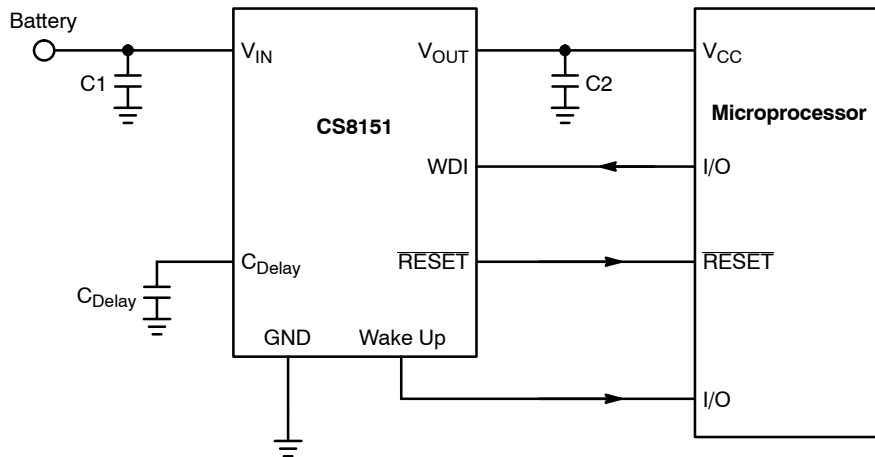

Figure 11. Application Diagram

TYPICAL PERFORMANCE CHARACTERISTICS

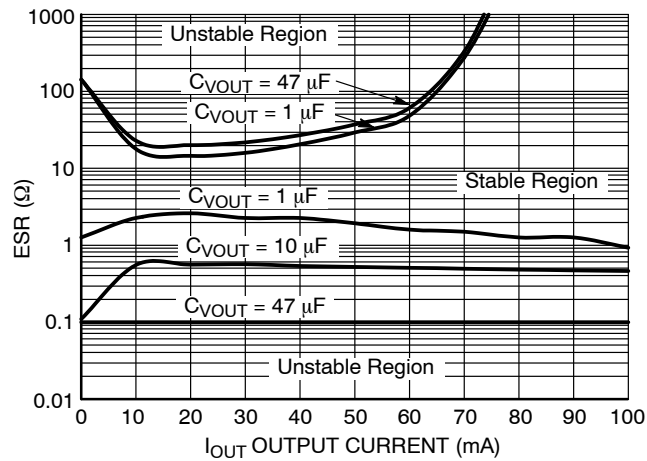

Figure 12. CS8151 Output Stability with Output Capacitor Change

CS8151

ORDERING INFORMATION

Device	Package	Shipping†
CS8151YDPS7G	D ² PAK-7 (Pb-Free)	50 Units / Rail
CS8151YDPSR7G	D ² PAK-7 (Pb-Free)	750 / Tape & Reel
CS8151YDWF16G	SO-16L (Pb-Free)	47 Units / Rail
CS8151YDWFR16G	SO-16L (Pb-Free)	1000 / Tape & Reel
CS8151D2G	SO-14L (Pb-Free)	55 Units / Rail
CS8151D2R2G	SO-14L (Pb-Free)	2500 / Tape & Reel

†For information on tape and reel specifications, including part orientation and tape sizes, please refer to our Tape and Reel Packaging Specifications Brochure, BRD8011/D.

CS8151

PACKAGE DIMENSIONS

SOIC-14
CASE 751A-03
ISSUE J

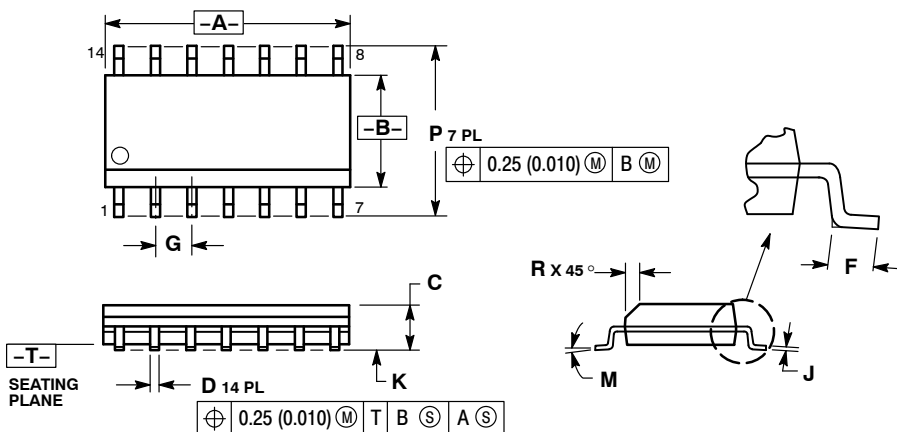

NOTES:

1. DIMENSIONING AND TOLERANCING PER ANSI Y14.5M, 1982.
2. CONTROLLING DIMENSION: MILLIMETER.
3. DIMENSIONS A AND B DO NOT INCLUDE MOLD PROTRUSION.
4. MAXIMUM MOLD PROTRUSION 0.15 (0.006) PER SIDE.
5. DIMENSION D DOES NOT INCLUDE DAMBAR PROTRUSION. ALLOWABLE DAMBAR PROTRUSION SHALL BE 0.127 (0.005) TOTAL IN EXCESS OF THE D DIMENSION AT MAXIMUM MATERIAL CONDITION.

DIM	MILLIMETERS		INCHES	
	MIN	MAX	MIN	MAX
A	8.55	8.75	0.337	0.344
B	3.80	4.00	0.150	0.157
C	1.35	1.75	0.054	0.068
D	0.35	0.49	0.014	0.019
F	0.40	1.25	0.016	0.049
G	1.27 BSC		0.050 BSC	
J	0.19	0.25	0.008	0.009
K	0.10	0.25	0.004	0.009
M	0°	7°	0°	7°
P	5.80	6.20	0.228	0.244
R	0.25	0.50	0.010	0.019

SOLDERING FOOTPRINT*

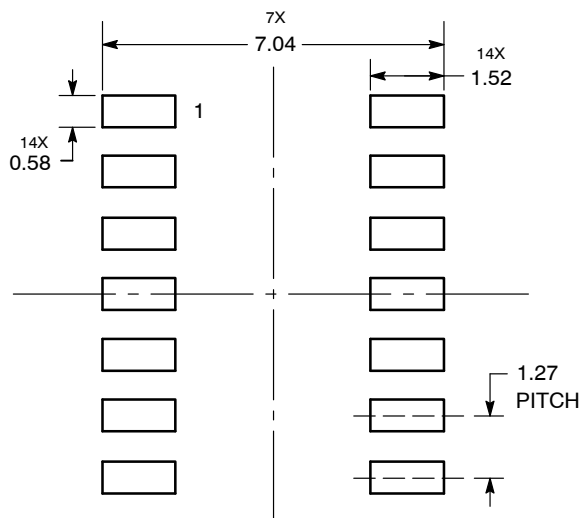

*For additional information on our Pb-Free strategy and soldering details, please download the ON Semiconductor Soldering and Mounting Techniques Reference Manual, SOLDERRM/D.

SMART REGULATOR is a registered trademark of Semiconductor Components Industries, LLC (SCILLC).

ON Semiconductor and are registered trademarks of Semiconductor Components Industries, LLC (SCILLC). SCILLC reserves the right to make changes without further notice to any products herein. SCILLC makes no warranty, representation or guarantee regarding the suitability of its products for any particular purpose, nor does SCILLC assume any liability arising out of the application or use of any product or circuit, and specifically disclaims any and all liability, including without limitation special, consequential or incidental damages. "Typical" parameters which may be provided in SCILLC data sheets and/or specifications can and do vary in different applications and actual performance may vary over time. All operating parameters, including "Typicals" must be validated for each customer application by customer's technical experts. SCILLC does not convey any license under its patent rights nor the rights of others. SCILLC products are not designed, intended, or authorized for use as components in systems intended for surgical implant into the body, or other applications intended to support or sustain life, or for any other application in which the failure of the SCILLC product could create a situation where personal injury or death may occur. Should Buyer purchase or use SCILLC products for any such unintended or unauthorized application, Buyer shall indemnify and hold SCILLC and its officers, employees, subsidiaries, affiliates, and distributors harmless against all claims, costs, damages, and expenses, and reasonable attorney fees arising out of, directly or indirectly, any claim of personal injury or death associated with such unintended or unauthorized use, even if such claim alleges that SCILLC was negligent regarding the design or manufacture of the part. SCILLC is an Equal Opportunity/Affirmative Action Employer. This literature is subject to all applicable copyright laws and is not for resale in any manner.

PUBLICATION ORDERING INFORMATION

LITERATURE FULFILLMENT:
Literature Distribution Center for ON Semiconductor
P.O. Box 5163, Denver, Colorado 80217 USA
Phone: 303-675-2175 or 800-344-3860 Toll Free USA/Canada
Fax: 303-675-2176 or 800-344-3867 Toll Free USA/Canada
Email: orderlit@onsemi.com

N. American Technical Support: 800-282-9855 Toll Free
USA/Canada
Europe, Middle East and Africa Technical Support:
Phone: 421 33 790 2910
Japan Customer Focus Center
Phone: 81-3-5773-3850

ON Semiconductor Website: www.onsemi.com
Order Literature: <http://www.onsemi.com/orderlit>

For additional information, please contact your local Sales Representative

CS8151/D