



Micro Commercial Components



Micro Commercial Components
20736 Marilla Street Chatsworth
CA 91311
Phone: (818) 701-4933
Fax: (818) 701-4939

MC7905CT THRU MC7912CT

Features

- Output current in excess of 1.0 Ampere
- Lead Free Finish/RoHS Compliant(Note 1) ("P" Suffix designates RoHS Compliant. See ordering information)
- Internal short-circuit current limiting And Internal thermal shut down protection
- Safe operating area protection
- Epoxy meets UL 94 V-0 flammability rating
- Moisture Sensitivity Level 1

Maximum Ratings @ T_A=25°C, Unless Otherwise Noted

Parameter	Symbol	Value	Unit
Input Voltage	V _I	-35	V
Operating Temperature Range	T _{OPR}	0---125	°C
Storage Temperature Range	T _{STG}	-55---150	°C

Three-Terminal Negative Voltage Regulators

MC7905CT

Electrical Characteristics (V_I=10V, I_o=500mA, 0°C<T_j<125°C,
C_i=2.0uF, C_o=1.0uF, Unless Otherwise Specified)

Parameter	Sym	Min	Typ	Max	Test conditions
Output Voltage	V _o	-4.8V	-5.0V	-5.2V	T _j =25°C
		-4.75V		-5.25V	-7V ≤ V _I ≤ -20V, 5mA ≤ I _o ≤ 1.0A, P _D ≤ 15W
Load Regulation	ΔV _o		15mV	100mV	5mA ≤ I _o ≤ 1.5A, T _j =25°C,
			5.0mV	50mV	250mA ≤ I _o ≤ 750mA, T _j =25°C
Line regulation	ΔV _o		12.5mV 4.0mV	50mV 15mV	-7V ≤ V _I ≤ -25V, T _j =25°C -8V ≤ V _I ≤ -12V, T _j =25°C
Quiescent Current	I _q		1.5mA	2.0mA	T _j =25°C, I _o =0
Quiescent Current Change	ΔI _q			0.5mA	-7V ≤ V _I ≤ -25V
				0.5mA	5mA ≤ I _o ≤ 1.0A
Output Noise Voltage	V _N		120μV		f=120Hz
Ripple Rejection	RR	54dB	60dB		-8V ≤ V _I ≤ -18V f=120Hz, T _j =25°C
Dropout Voltage	V _d		1.1V		I _o =1.0A, T _j =25°C
Peak Output Current	I _{opeak}		2.1A		T _j =25°C
Temperature Coefficient of Output voltage	ΔV _o / ΔT _j		-0.4mV/°C		0°C ≤ T _j ≤ 125°C, I _o =5mA

Notes:1.High Temperature Solder Exemption Applied, see EU Directive Annex 7.

TO-220

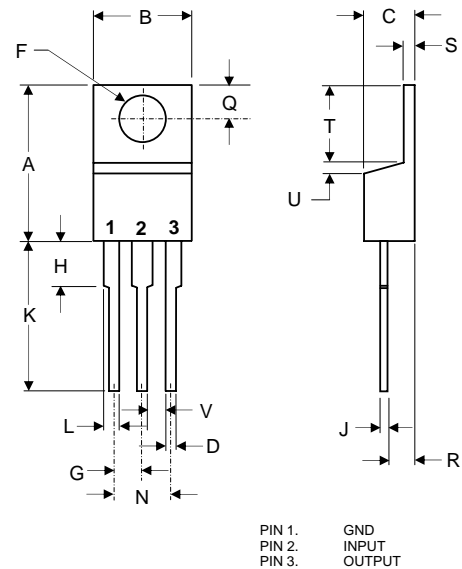

PIN 1. GND
PIN 2. INPUT
PIN 3. OUTPUT

DIM	INCHES		MM		NOTE
	MIN	MAX	MIN	MAX	
A	.560	.625	14.22	15.88	
B	.380	.420	9.65	10.67	
C	.140	.190	3.56	4.82	
D	.020	.045	0.51	1.14	
F	.139	.161	3.53	4.09	∅
G	.190	.110	2.29	2.79	
H	---	.250	---	6.35	
J	.012	.025	0.30	0.64	
K	.500	.580	12.70	14.73	
L	.045	.060	1.14	1.52	
N	.190	.210	4.83	5.33	
Q	.100	.135	2.54	3.43	
R	.080	.115	2.04	2.92	
S	.045	.055	1.14	1.39	
T	.230	.270	5.84	6.86	
U	----	.050	----	1.27	
V	.045	----	1.15	----	

MC7906CT

Electrical Characteristics (Vi=11V, Io=500mA, 0°C<Tj<125°C, Ci=2.0uF, Co=1.0uF, Unless Otherwise Specified)

Parameter	Sym	Min	Typ	Max	Test conditions
Output Voltage	Vo	-5.75V	-6.0V	-6.25V	Tj=25°C
		-5.70V		-6.30V	-8V ≤ V1 ≤ -21V, 5mA ≤ Io ≤ 1.0A, Po ≤ 15W
Load Regulation	ΔVo		15mV	160mV	5mA ≤ Io ≤ 1.5A, Tj=25°C,
			5.0mV	80mV	250mA ≤ Io ≤ 750mA, Tj=25°C
Line regulation	ΔVo		12.5mV	160mV	-8.0V ≤ V1 ≤ -25V, Tj=25°C
			4.0mV	80mV	-9V ≤ V1 ≤ -13V, Tj=25°C
Quiescent Current	Iq		1.5mA	2.0mA	Tj=25°C, Io=0
Quiescent Current Change	ΔIq			1.0mA 0.5mA	-10.5V ≤ V1 ≤ -25V 5mA ≤ Io ≤ 1.0A
Output Noise Voltage	VN		200μV		10Hz ≤ f ≤ 100KHz Tj=25°C
Ripple Rejection	RR	54dB	60dB		f=120Hz -9V ≤ V1 ≤ -13V, Tj=25°C
Dropout Voltage	Vd		1.1V		Io=1.0A, Tj=25°C
Peak Output Current	Iopeak		2.1A		Tj=25°C
Temperature Coefficient of Output voltage	ΔVo/ΔTj		-0.5mV/°C		0°C ≤ Tj ≤ 125°C, Io=5mA

MC7908CT

Electrical Characteristics (Vi=14V, Io=500mA, 0°C<Tj<125°C, Ci=2.0uF, Co=1.0uF, Unless Otherwise Specified)

Parameter	Sym	Min	Typ	Max	Test conditions
Output Voltage	Vo	-7.70V	-8.0V	-8.30V	Tj=25°C
		-7.60V		-8.40V	-10.5V ≤ V1 ≤ -23V, 5mA ≤ Io ≤ 1.0A, Po=15W
Load Regulation	ΔVo		12mV	160mV	5mA ≤ Io ≤ 1.5A, Tj=25°C,
			4.0mV	80mV	250mA ≤ Io ≤ 750mA, Tj=25°C
Line regulation	ΔVo		6.0mV	160mV	-10.5V ≤ V1 ≤ -25V, Tj=25°C
			2.0mV	80mV	-11V ≤ V1 ≤ -17V, Tj=25°C
Quiescent Current	Iq		2.2mA	4.5mA	Tj=25°C, Io=0
Quiescent Current Change	ΔIq			1.0mA 0.5mA	-10.5V ≤ V1 ≤ -25V 5mA ≤ Io ≤ 1.0A
Output Noise Voltage	VN		52μV		10Hz ≤ f ≤ 100KHz Tj=25°C
Ripple Rejection	RR	56dB	71dB		f=120Hz -10.5V ≤ V1 ≤ -25V Tj=25°C
Dropout Voltage	Vd		2.0V		Io=1.0A, Tj=25°C
Peak Output Current	Iopeak		2.1A		Tj=25°C
Temperature Coefficient of Output voltage	ΔVo/ΔTj		-0.6mV/°C		0°C ≤ Tj ≤ 125°C, Io=5mA

MC7909CT

Electrical Characteristics ($V_i=15V$, $I_o=500mA$, $0^\circ C < T_j < 125^\circ C$, $C_i=2.0\mu F$, $C_o=1.0\mu F$, Unless Otherwise Specified)

Parameter	Sym	Min	Typ	Max	Test conditions
Output Voltage	V_o	-8.70V	-9.0V	-9.30V	$T_j=25^\circ C$
		-8.60V		-9.40V	$-11.5V \leq V_1 \leq -24V$, $5mA \leq I_o \leq 1.0A$, $P_D \leq 15W$
Load Regulation	ΔV_o		12mV	180mV	$5mA \leq I_o \leq 1.5A$, $T_j=25^\circ C$,
			4.0mV	90mV	$250mA \leq I_o \leq 750mA$, $T_j=25^\circ C$
Line regulation	ΔV_o		10mV	180mV	$-11.5V \leq V_1 \leq -26V$, $T_j=25^\circ C$
			5.0mV	90mV	$-12V \leq V_1 \leq -18V$, $T_j=25^\circ C$
Quiescent Current	I_q		3.0mA	6.0mA	$T_j=25^\circ C$, $I_o=0$
Quiescent Current Change	ΔI_q			1.0mA 0.5mA	$-11.5V \leq V_1 \leq -26V$ $5mA \leq I_o \leq 1.0A$
Output Noise Voltage	V_N		17 μ V		$10Hz \leq f \leq 100KHz$ $T_j=25^\circ C$
Ripple Rejection	RR	54dB	60dB		$f=120Hz$, $-11.5V \leq V_1 \leq -26V$, $T_j=25^\circ C$
Dropout Voltage	V_d		1.1V		$I_o=1.0A$, $T_j=25^\circ C$
Peak Output Current	I_{opeak}		2.1A		$T_j=25^\circ C$
Temperature Coefficient of Output voltage	$\Delta V_o / \Delta T_j$		-0.6mV/ $^\circ C$		$0^\circ C \leq T_j \leq 125^\circ C$, $I_o=5mA$

MC7912CT

Electrical Characteristics (Vi=19V, Io=500mA, 0°C<Tj<125°C, Ci=2.0uF, Co=1.0uF, Unless Otherwise Specified)

Parameter	Sym	Min	Typ	Max	Test conditions
Output Voltage	Vo	-11.50V	-12V	-12.50V	Tj=25°C
		-11.40V		-12.60V	-14.5V ≤ V1 ≤ -27V, 5mA ≤ Io ≤ 1.0A, PD ≤ 15W
Load Regulation	ΔVo		15mV	200mV	5.0mA ≤ Io ≤ 1.5A, Tj=25°C,
			5.0mV	75mV	250mA ≤ Io ≤ 750mA, Tj=25°C
Line regulation	ΔVo		5.0mV 3.0mV	80mV 30mV	-14.5V ≤ V1 ≤ -30V, Tj=25°C -16V ≤ V1 ≤ -22V, Tj=25°C
Quiescent Current	Iq		2.0mA	3.0mA	Tj=25°C, Io=0
Quiescent Current Change	ΔIq			0.5mA 0.5mA	-14.5V ≤ V1 ≤ -30V 5mA ≤ Io ≤ 1.0A
Output Noise Voltage	VN		300μV		10Hz ≤ f ≤ 100KHz Tj=25°C
Ripple Rejection	RR	54dB	60dB		f=120Hz, -14.5V ≤ V1 ≤ -30V, Tj=25°C
Dropout Voltage	Vd		1.1V		Io=1.0A, Tj=25°C
Peak Output Current	Iopeak		2.1A		Tj=25°C
Temperature Coefficient of Output voltage	ΔVo/ΔTj		-0.8mV/°C		0°C ≤ Tj ≤ 125°C, Io=5mA

Marking:

MCC
79XXCT

XX:05~12

MC7905CT thru MC7912CT

Representation Schematic Diagram

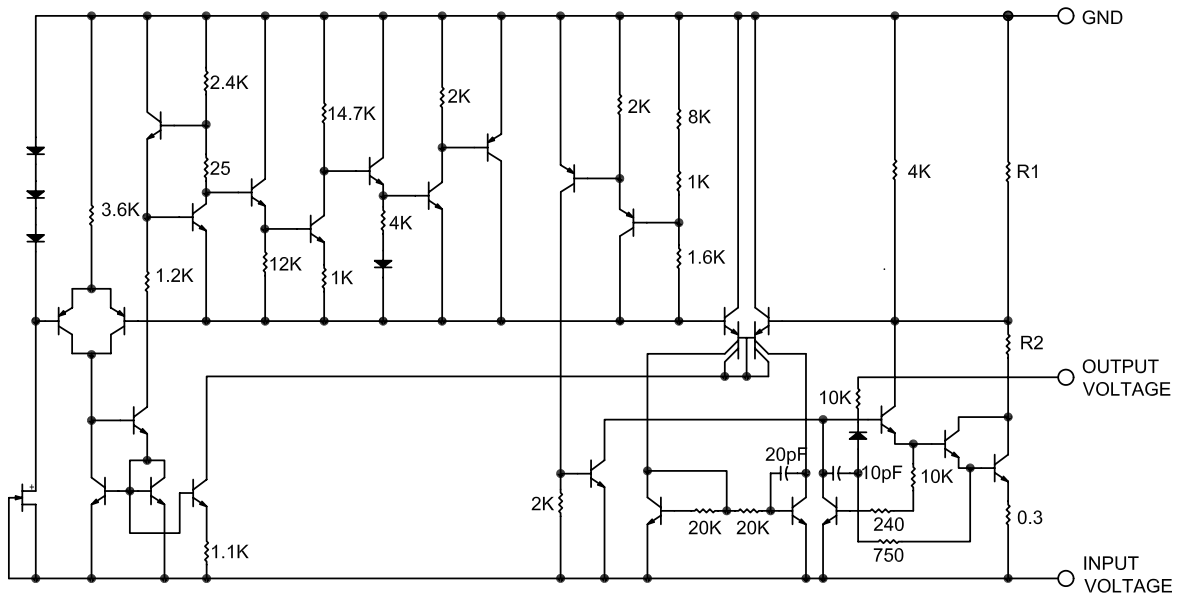



Micro Commercial Components

Ordering Information :

Device	Packing
Part Number-BP	Bulk; 1Kpcs/Box

IMPORTANT NOTICE

Micro Commercial Components Corp. reserves the right to make changes without further notice to any product herein to make corrections, modifications, enhancements, improvements, or other changes. **Micro Commercial Components Corp.** does not assume any liability arising out of the application or use of any product described herein; neither does it convey any license under its patent rights, nor the rights of others. The user of products in such applications shall assume all risks of such use and will agree to hold **Micro Commercial Components Corp.** and all the companies whose products are represented on our website, harmless against all damages.

LIFE SUPPORT

MCC's products are not authorized for use as critical components in life support devices or systems without the express written approval of Micro Commercial Components Corporation.

CUSTOMER AWARENESS

Counterfeiting of semiconductor parts is a growing problem in the industry. Micro Commercial Components (MCC) is taking strong measures to protect ourselves and our customers from the proliferation of counterfeit parts. MCC strongly encourages customers to purchase MCC parts either directly from MCC or from Authorized MCC Distributors who are listed by country on our web page cited below. Products customers buy either from MCC directly or from Authorized MCC Distributors are genuine parts, have full traceability, meet MCC's quality standards for handling and storage. **MCC will not provide any warranty coverage or other assistance for parts bought from Unauthorized Sources.** MCC is committed to combat this global problem and encourage our customers to do their part in stopping this practice by buying direct or from authorized distributors.

www.mccsemi.com