

# PQxxxEZ1HZxH Series

Low Voltage Operation  
Low Power-Loss Voltage Regulators

## ■ Features

- 1.Low voltage operation (Minimum operating voltage: 2.35V)  
2.5V input → available 1.5 to 1.8V
- 2.Low dissipation current  
Dissipation current at no load: MAX. 2mA  
Output OFF-state dissipation current: MAX. 5μA
- 3.Low power-loss
- 4.Built-in overcurrent and overheat protection functions
- 5.RoHS directive compliant

## ■ Applications

- 1.Power supplies for personal computers and peripheral equipment
- 2.Power supplies for various electronic equipment such as DVD player or STB

## ■ Model Line-up

Output current	Package type	Output voltage		
		1.5V	1.8V	2.5V
1.5A	Taping	PQ015EZ1HZPH	PQ018EZ1HZPH	PQ025EZ1HZPH
	Sleeve	PQ015EZ1HZZH	PQ018EZ1HZZH	PQ025EZ1HZZH
		3.0V	3.3V	
1.5A	Taping	PQ030EZ1HZPH	PQ033EZ1HZPH	
	Sleeve	PQ030EZ1HZZH	PQ033EZ1HZZH	

## ■ Absolute Maximum Ratings

(Ta=25°C)

Parameter	Symbol	Rating	Unit
*1 Input voltage	V <sub>IN</sub>	10	V
*1 ON/OFF control terminal voltage	V <sub>C</sub>	10	V
Output current	I <sub>O</sub>	1.5	A
*2 Power dissipation	P <sub>D</sub>	8	W
*3 Junction temperature	T <sub>j</sub>	150	°C
Operating temperature	T <sub>opr</sub>	-40 to +85	°C
Storage temperature	T <sub>stg</sub>	-40 to +150	°C
Soldering temperature	T <sub>sol</sub>	260(10s)	°C

- \*1 All are open except GND and applicable terminals.  
\*2 Pb: With infinite heat sink  
\*3 Overheat protection may operate at T<sub>j</sub>:125°C to 150°C

## ■ Outline Dimensions

(Unit : mm)

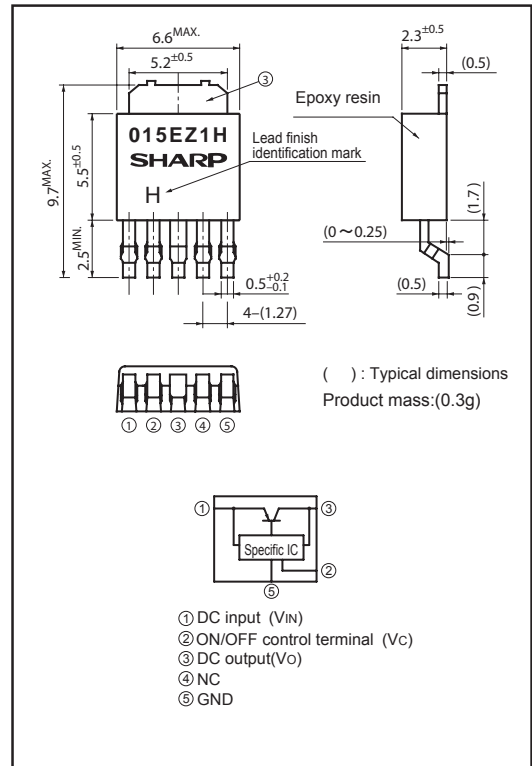

Lead finish:Lead-free solder plating  
(Composition: Sn2Cu)

Notice The content of data sheet is subject to change without prior notice.

In the absence of confirmation by device specification sheets, SHARP takes no responsibility for any defects that may occur in equipment using any SHARP devices shown in catalogs, data books, etc. Contact SHARP in order to obtain the latest device specification sheets before using any SHARP device.

### ■ Electrical Characteristics

(Unless otherwise specified, condition shall be  $V_{IN}=V_O(TYP.)+1V$ ,  $I_O=0.5A$ ,  $V_C=2.7V$ ,  $T_a=25^\circ C$ )

Parameter	Symbol	Conditions	MIN.	TYP.	MAX.	Unit
Input voltage	$V_{IN}$	—	Refer to the table 1			V
Output voltage	$V_O$	—	Refer to the table 2			V
Load regulation	$R_{regL}$	$I_O=5mA$ to 1.5A	—	0.2	2.0	%
Line regulation	$R_{regl}$	$V_{IN}=V_O(TYP.)+1V$ to $V_O(TYP.)+6V$	—	0.1	1.0	%
Temperature coefficient of output voltage	$T_C V_O$	$T_j=0$ to $125^\circ C$ , $I_O=5mA$	—	$\pm 0.01$	—	%/ $^\circ C$
Ripple Rejection	RR	Refer to Fig.2	45	60	—	dB
*4 Dropout voltage	$V_{I-O}$	*5 $I_O=1.25A$	—	—	1.0	V
*6 ON-state voltage for control	$V_{C(ON)}$	—	2.0	—	—	V
ON-state current for control	$I_{C(ON)}$	—	—	—	200	$\mu A$
OFF-state voltage for control	$V_{C(OFF)}$	—	—	—	0.8	V
OFF-state current for control	$I_{C(OFF)}$	$V_C=0.4V$	—	—	2	$\mu A$
Quiescent current	$I_q$	$I_O=0A$	—	1	2	mA
Output OFF-state dissipation current	$I_{qs}$	$I_O=0A$ , $V_C=0.4V$	—	—	5	$\mu A$

\*4 Applied PQ030EZ1HZxH, PQ033EZ1HZxH

\*5 Input voltage shall be the value when output voltage is 95% in comparison with the initial value.

\*6 In case of opening control terminal ②, output voltage turns off.

Table.1 Input Voltage Line-up

(Unless otherwise specified, condition shall be  $I_O=0.5A$ ,  $V_C=2.7V$ ,  $T_a=25^\circ C$ )

Model No.	Symbol	Conditions	MIN.	TYP.	MAX.	Unit
PQ015EZ1HZxH	$V_{IN}$	—	2.35	—	10	V
PQ018EZ1HZxH	$V_{IN}$	—	2.35	—	10	V
PQ025EZ1HZxH	$V_{IN}$	—	3.0	—	10	V
PQ030EZ1HZxH	$V_{IN}$	—	3.5	—	10	V
PQ033EZ1HZxH	$V_{IN}$	—	3.8	—	10	V

Table.2 Output Voltage Line-up

(Unless otherwise specified, condition shall be  $V_{IN}=V_O(TYP.)+1V$ ,  $I_O=0.5A$ ,  $V_C=2.7V$ ,  $T_a=25^\circ C$ )

Model No.	Symbol	Conditions	MIN.	TYP.	MAX.	Unit
PQ015EZ1HZxH	$V_O$	—	1.45	1.5	1.55	V
PQ018EZ1HZxH	$V_O$	—	1.75	1.8	1.85	V
PQ025EZ1HZxH	$V_O$	—	2.438	2.5	2.562	V
PQ030EZ1HZxH	$V_O$	—	2.925	3.0	3.075	V
PQ033EZ1HZxH	$V_O$	—	3.218	3.3	3.382	V

Fig.1 Test Circuit

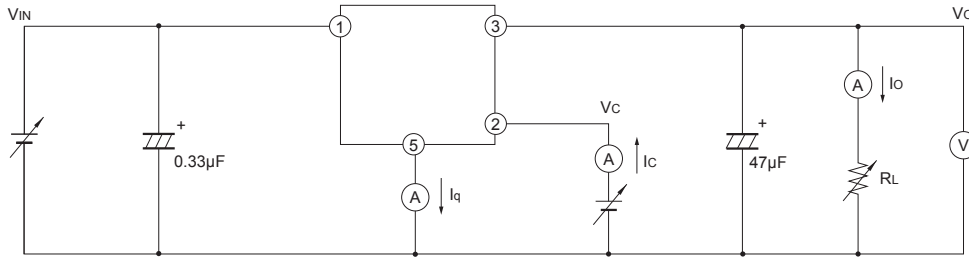
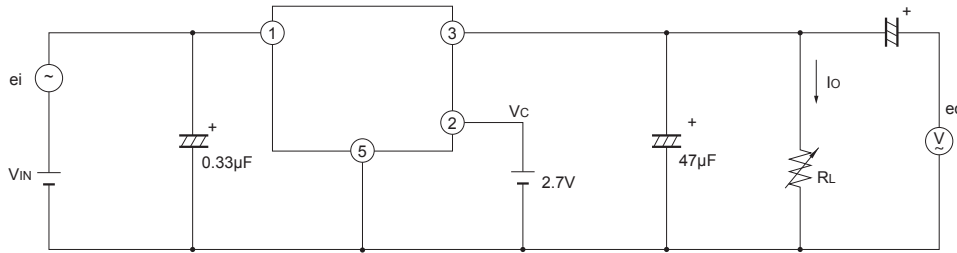
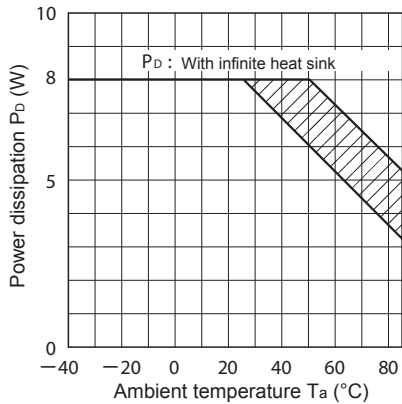

Fig.2 Test Circuit for Ripple Rejection



f=120Hz(sine wave)  
 ei(rms)=0.5V  
 $V_{IN} = V_O(TYP) + 2V$   
 $I_O = 0.3A$   
 $RR = 20 \log(ei(rms)/eo(rms))$

Fig.3 Power Dissipation vs. Ambient Temperature



Note) Oblique line portion: Overheat protection may operate in this area.

Fig.4 Overcurrent Protection Characteristics (PQ015EZ1HZxH)

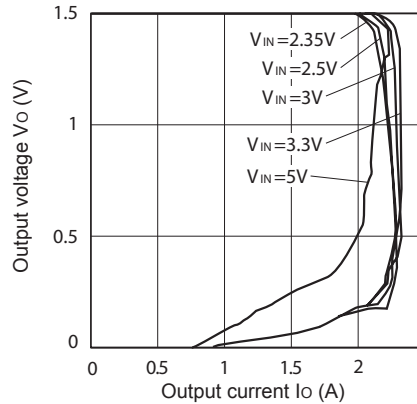

Fig.5 Overcurrent Protection Characteristics (Typical Value)(PQ018EZ1HZxH)

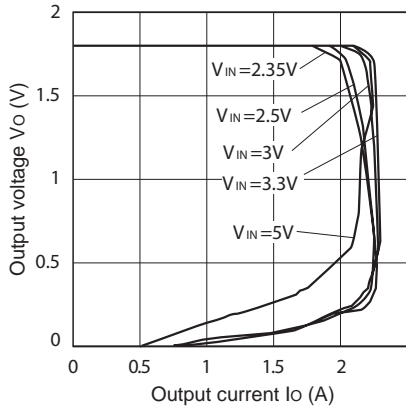

Fig.6 Overcurrent Protection Characteristics (PQ025EZ1HZxH)

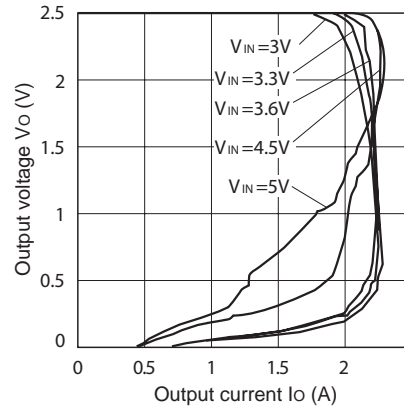

Fig.7 Overcurrent Protection Characteristics (PQ030EZ1HZxH)

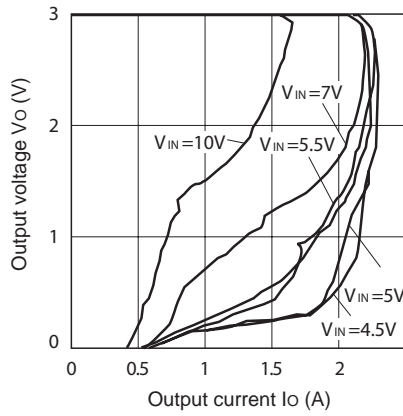

Fig.8 Overcurrent Protection Characteristics (PQ033EZ1HZxH)

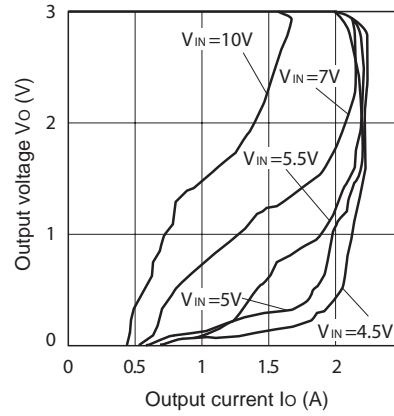

Fig.9 Output Voltage vs. Junction Temperature (PQ015EZ1HZxH)

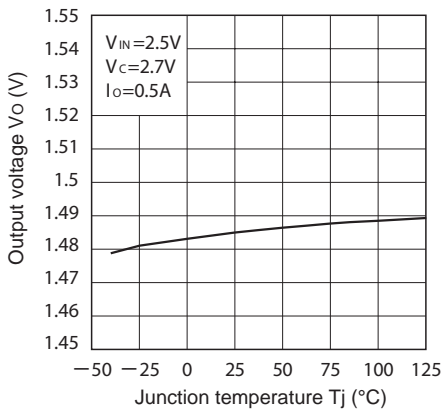

Fig.10 Output Voltage vs. Junction Temperature (PQ018EZ1HZxH)

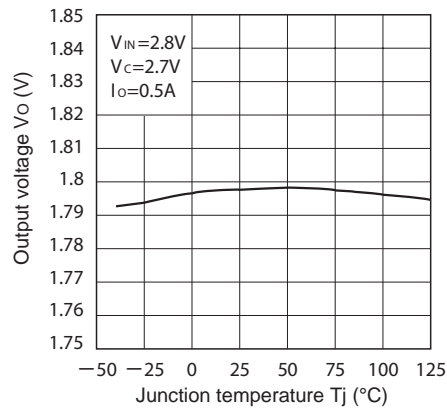

Fig.11 Output Voltage vs. Junction Temperature (PQ025EZ1HZxH)

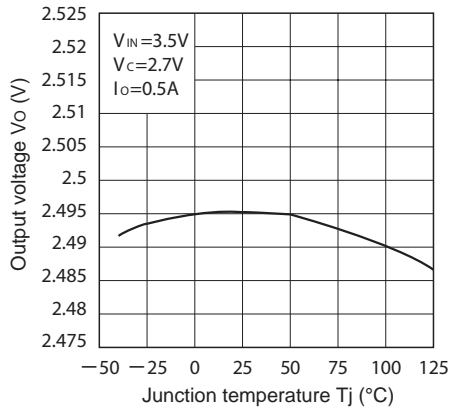

Fig.12 Output Voltage vs. Junction Temperature (PQ030EZ1HZxH)

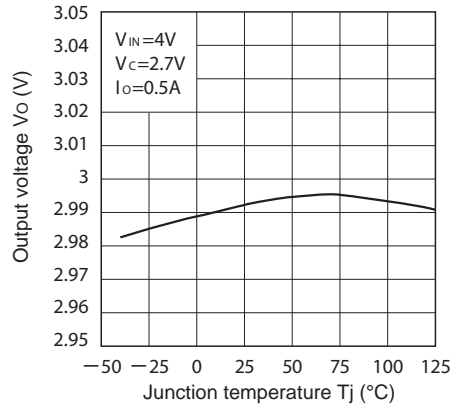

Fig.13 Output Voltage vs. Junction Temperature (PQ033EZ1HZxH)

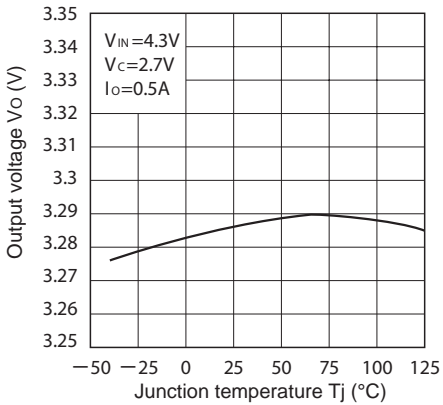

Fig.14 Output Voltage vs. Input Voltage (PQ015EZ1HZxH)

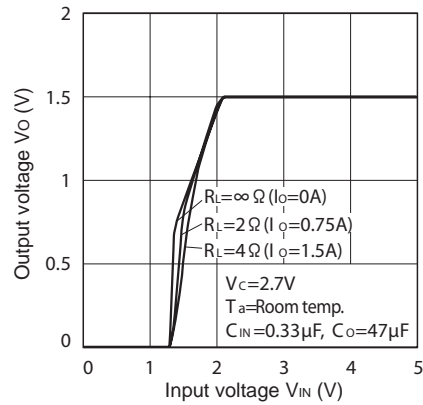

Fig.15 Output Voltage vs. Input Voltage (PQ018EZ1HZxH)

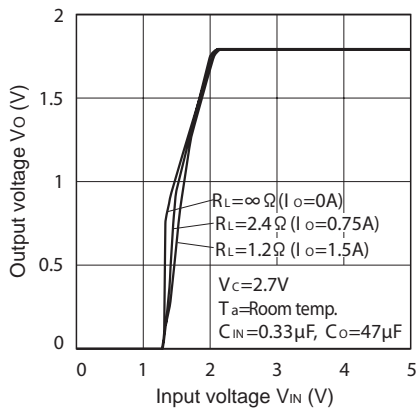

Fig.16 Output Voltage vs. Input Voltage (PQ025EZ1HZxH)

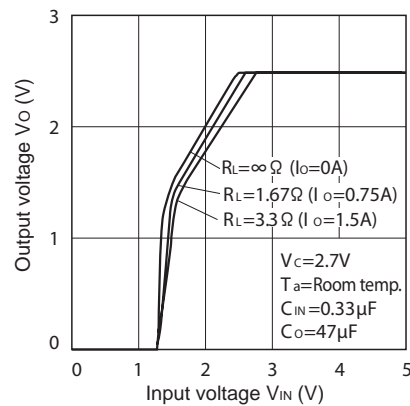

Fig.17 Output Voltage vs. Input Voltage (PQ030EZ1HZxH)

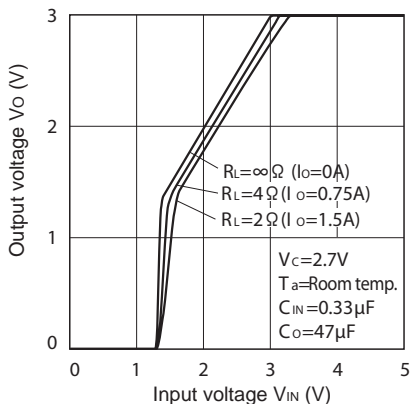

Fig.18 Output Voltage vs. Input Voltage (PQ033EZ1HZxH)

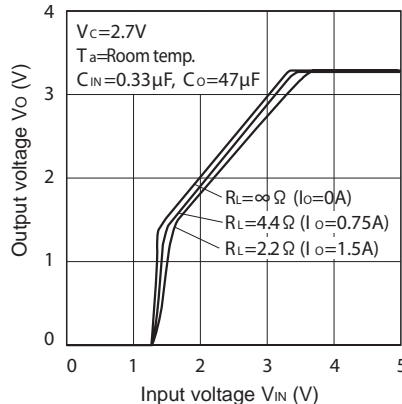

Fig.19 Circuit Operating Current vs. Input Voltage (PQ015EZ1HZxH)

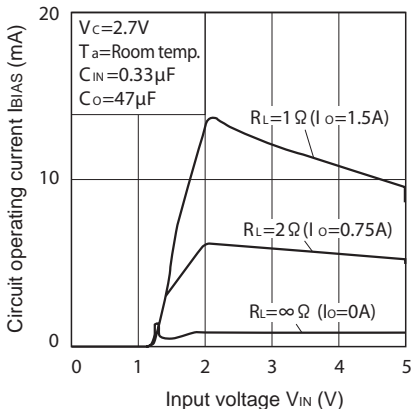

Fig.20 Circuit Operating Current vs. Input Voltage (PQ018EZ1HZxH)

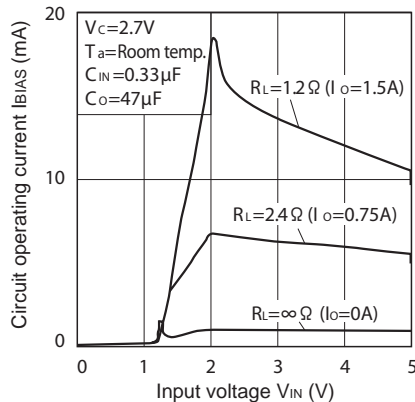

Fig.21 Circuit Operating Current vs. Input Voltage (PQ025EZ1HZxH)

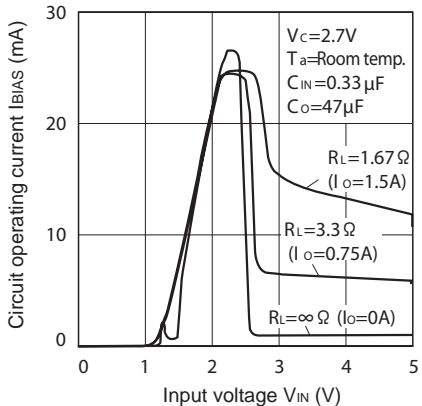

Fig.22 Circuit Operating Current vs. Input Voltage (PQ030EZ1HZxH)

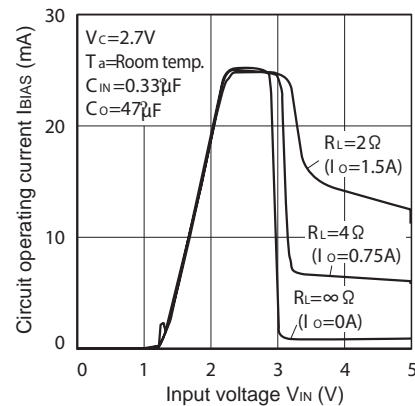

Fig.23 Circuit Operating Current vs. Input Voltage (PQ033EZ1HZxH)

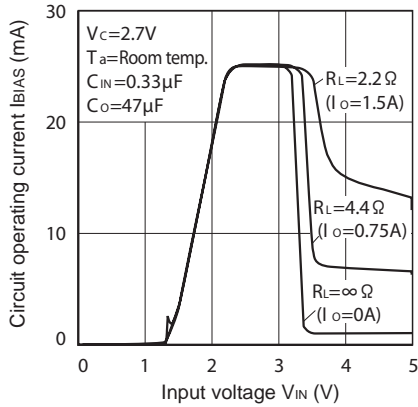

Fig.24 Dropout Voltage vs. Junction Temperature

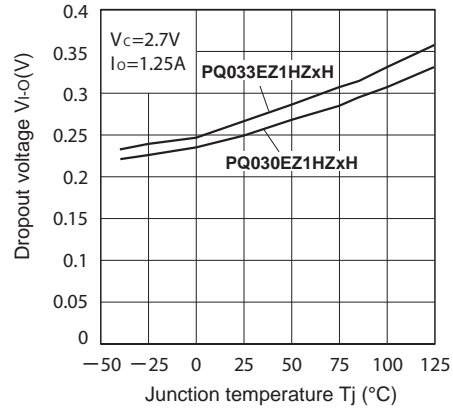

Fig.25 Quiescent Current vs. Junction Temperature

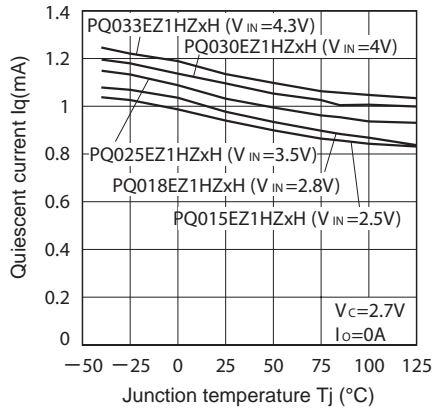

Fig.26 Ripple Rejection vs. Input Ripple Frequency

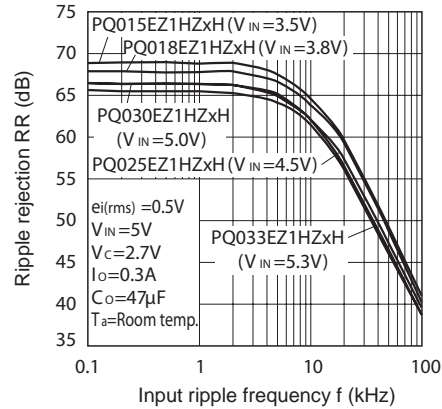

Fig.27 Ripple Rejection vs. Output Current

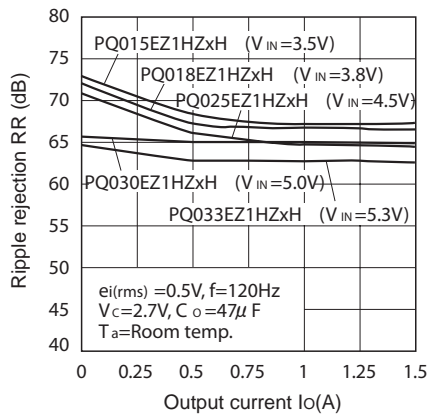
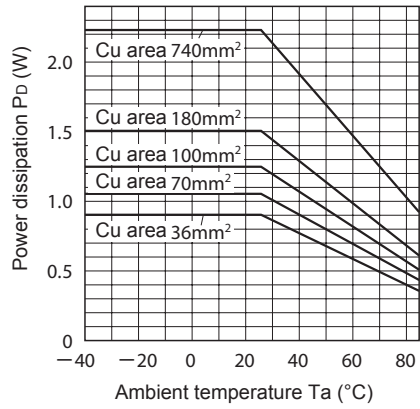
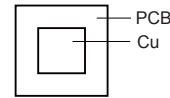

Fig.28 Power Dissipation vs. Ambient Temperature (Typical Value)



Mounting PCB



Material : Glass-cloth epoxy resin  
 Size : 50×50×1.6mm  
 Cu thickness : 35μm

■ Typical Application

