

PQ070XNA1ZPH

Low Voltage Operation, Compact Surface Mount type Low Power-Loss Voltage Regulators

■ Features

1. Low voltage operation
(Minimum operating voltage: 2.35V)
2. Output current : 1A
3. Low dissipation current
(Dissipation current at no load: MAX. 2mA
Output OFF-state dissipation current: MAX. 5μA)
4. Compliant Ceramic capacitors
5. Built-in ON/OFF function
6. Built-in overcurrent and overheat protection functions
7. Correspond to flow soldering
8. RoHS directive compliant

■ Applications

1. Personal computers and peripheral equipment
2. Power supplies for various digital electronic equipment such as DVD player or STB

■ Absolute Maximum Ratings

(Ta=25°C)

Parameter	Symbol	Rating	Unit
*1 Input voltage	V _{IN}	10	V
*1 Output control voltage	V _C	10	V
*1 Output adjustment pin voltage	V _{adj}	5	V
Output current	I _O	1	A
*2 Power dissipation	P _D	8	W
*3 Junction temperature	T _J	150	°C
Operating temperature	T _{opr}	-40 to +85	°C
Storage temperature	T _{stg}	-40 to +150	°C
Soldering temperature	T _{sol}	260(10s)	°C

*1 All are open except GND and applicable terminals.

*2 P_D: With infinite heat sink

*3 There is case that over heat protection operates at the temperature T_J: 125°C to 150°C, so this item cannot be used in this temperature range.

■ Outline Dimensions

(Unit : mm)

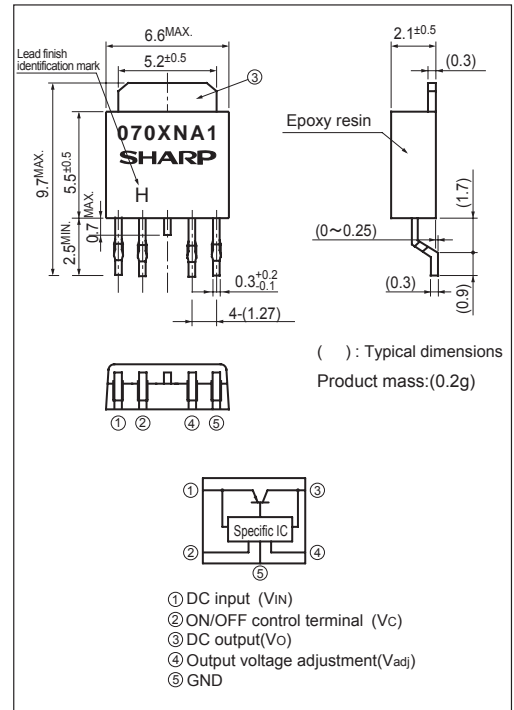

Lead finish: Lead-free solder plating
(Composition: Sn2Cu)

Notice The content of data sheet is subject to change without prior notice.

In the absence of confirmation by device specification sheets, SHARP takes no responsibility for any defects that may occur in equipment using any SHARP devices shown in catalogs, data books, etc. Contact SHARP in order to obtain the latest device specification sheets before using any SHARP device.

Electrical Characteristics

(Unless otherwise specified, condition shall be $V_{IN}=5V, V_O=3V(R_1=1k\Omega), I_O=0.5A, V_C=2.7V, T_a=25^\circ C$)

Parameter	Symbol	Conditions	MIN.	TYP.	MAX.	Unit
Input voltage	V_{IN}	-	2.35	-	10	V
Output voltage	V_O	-	1.5	-	7	V
Load regulation	Reg_L	$I_O=5mA$ to 1A	-	0.2	1.0	%
Line regulation	Reg_L	$V_{IN}=4$ to 8V, $I_O=5mA$	-	0.2	1.0	%
Ripple rejection	RR	Refer to Fig.2	-	60	-	dB
Dropout voltage	V_{I-O}	$V_{IN}=2.85V, I_O=0.5A$	-	-	0.5	V
Reference voltage	V_{REF}	-	1.206	1.23	1.254	V
Temperature coefficient of reference voltage	$T_C V_{REF}$	$T_j=0$ to $+125^\circ C, I_O=5mA$	-	± 1.0	-	%
ON-state voltage for control	$V_{C(ON)}$	*4	2.0	-	-	V
ON-state current for control	$I_{C(ON)}$	-	-	-	200	μA
OFF-state voltage for control	$V_{C(OFF)}$	$I_O=0A$	-	-	0.6	V
OFF-state current for control	$I_{C(OFF)}$	$I_O=0A, V_C=0.4V$	-	-	5	μA
Quiescent current	I_q	$I_O=0A$	-	1	2	mA
Output OFF-state dissipation current	I_{qs}	$V_C=0.4V$	-	-	5	μA

*4 In case of opening control terminal ②, output voltage turns off

Fig.1 Test Circuit

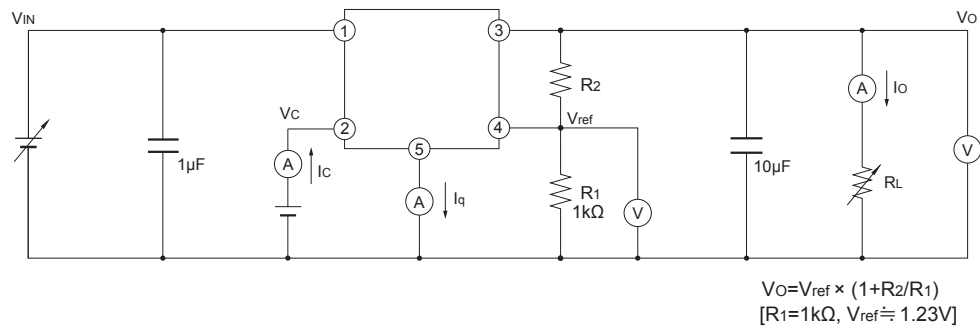

Fig.2 Test Circuit for Ripple Rejection

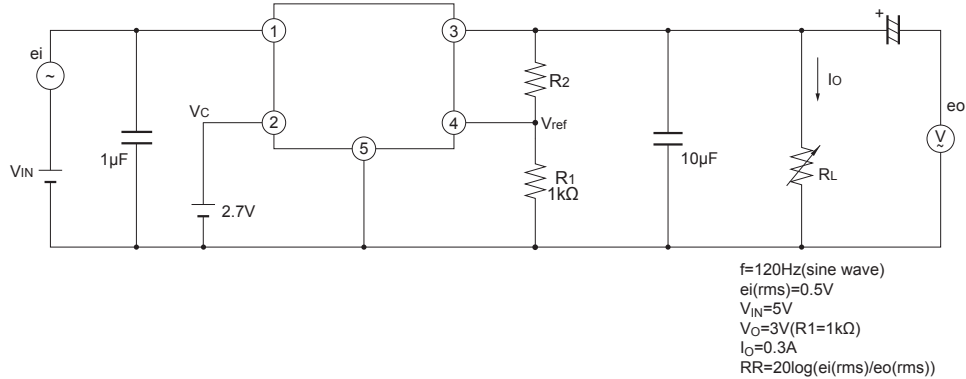
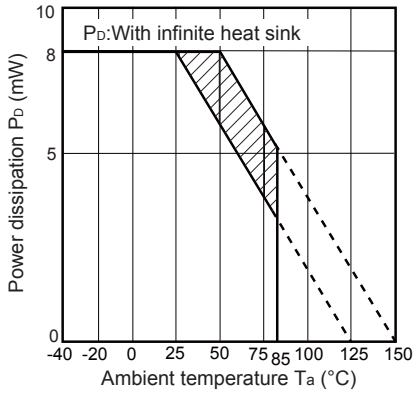

Fig.3 Power Dissipation vs. Ambient Temperature



Note) Oblique line portion: Overheat protection may operate in this area.

Fig.4 Overcurrent Protection Characteristics

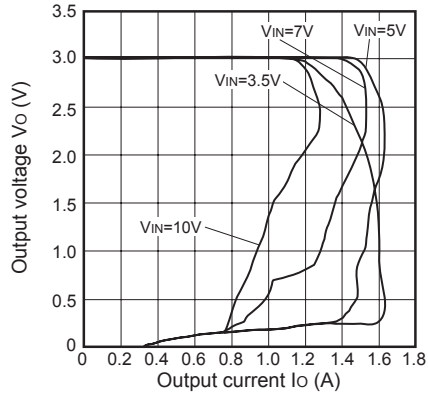

Fig.5 Output Voltage vs. Ambient Temperature

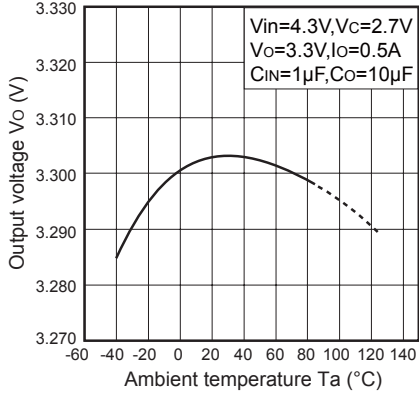

Fig.6 Dropout Voltage vs. Ambient Temperature

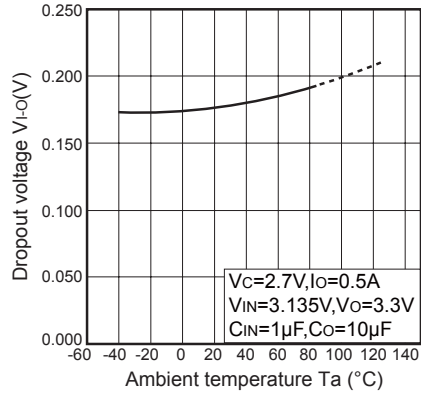

Fig.7 Quiescent Current vs. Ambient Temperature

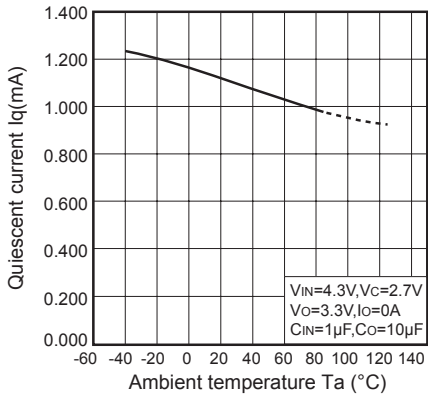

Fig.8 Output Voltage vs. Input Voltage

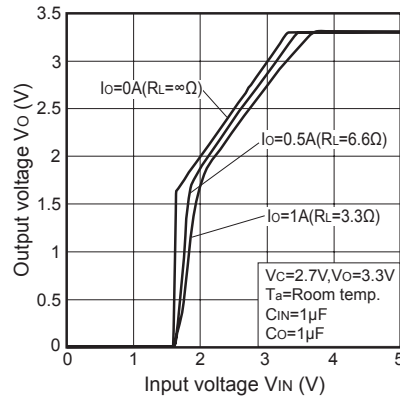

Fig.9 Circuit Operating Current vs. Input Voltage

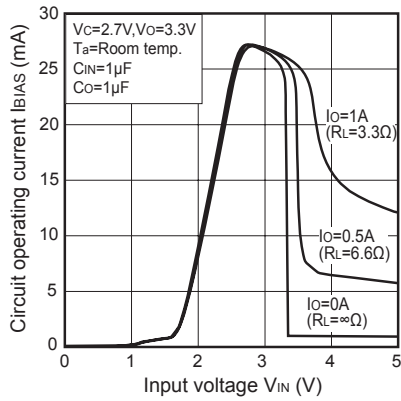

Fig.10 Dropout Voltage vs. Output Current

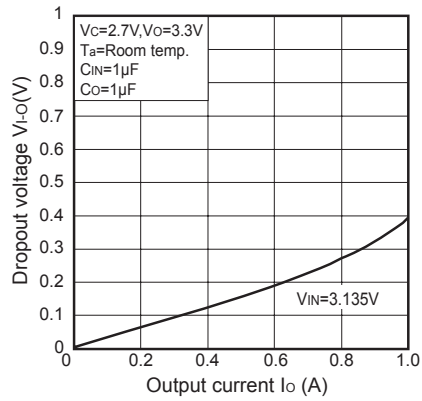

Fig.11 Ripple Rejection vs. Input Ripple Frequency

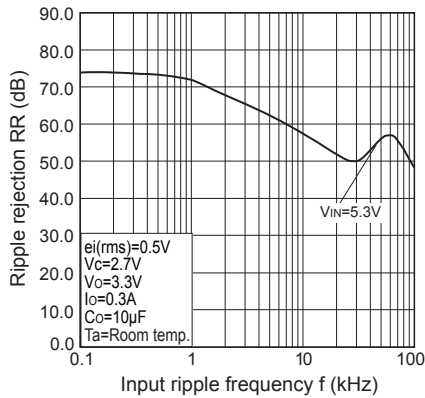

Fig.12 Ripple Rejection vs. Output Current

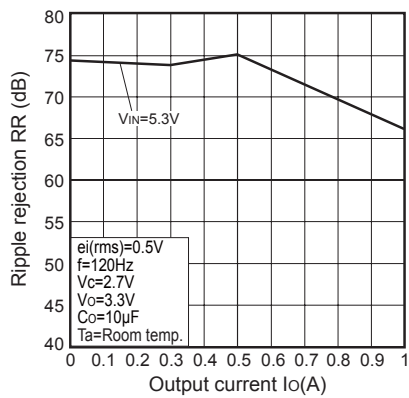
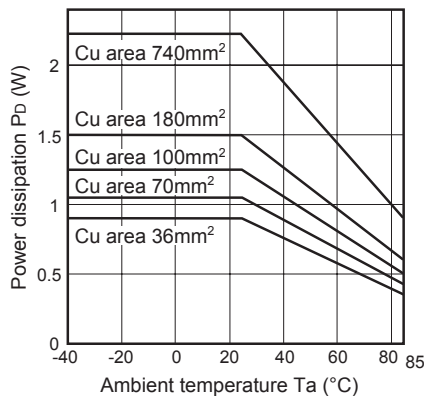
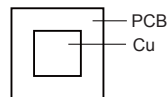

Fig.13 Power Dissipation vs. Ambient Temperature (Typical Value)



Mounting PCB



Material : Glass-cloth epoxy resin
 Size : 50×50×1.6mm
 Cu thickness : 35μm

Fig.14 Output Voltage Adjustment Characteristics

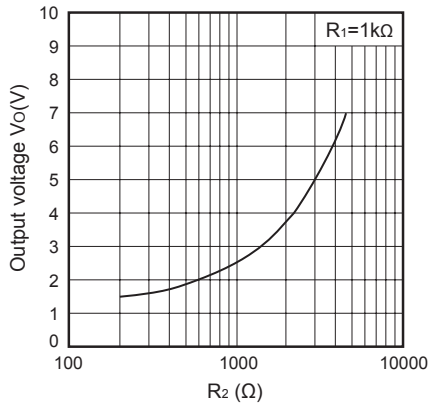

■ Typical Application

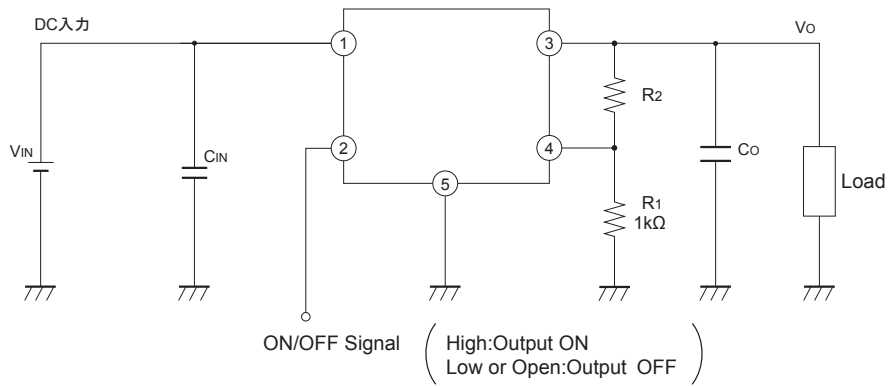

■ Setting of Output Voltage

Output voltage is able to set from 1.5V to 7V when resistors R₁ and R₂ are attached to ③,④,⑤ terminals. As for the external resistors to set output voltage, refer to the figure below and Fig.14.

