

LM78LXX Series

3-Terminal Positive Regulators

General Description

The LM78LXX series of three terminal positive regulators is available with several fixed output voltages making them useful in a wide range of applications. When used as a zener diode/resistor combination replacement, the LM78LXX usually results in an effective output impedance improvement of two orders of magnitude, and lower quiescent current. These regulators can provide local on card regulation, eliminating the distribution problems associated with single point regulation. The voltages available allow the LM78LXX to be used in logic systems, instrumentation, HiFi, and other solid state electronic equipment.

The LM78LXX is available in the plastic TO-92 (Z) package, the plastic SO-8 (M) package and a chip sized package (8-Bump micro SMD) using National's micro SMD package technology. With adequate heat sinking the regulator can deliver 100mA output current. Current limiting is included to limit the peak output current to a safe value. Safe area protection for the output transistors is provided to limit internal power dissipation.

If internal power dissipation becomes too high for the heat sinking provided, the thermal shutdown circuit takes over preventing the IC from overheating.

Features

- LM78L05 in micro SMD package
- Output voltage tolerances of $\pm 5\%$ over the temperature range
- Output current of 100mA
- Internal thermal overload protection
- Output transistor safe area protection
- Internal short circuit current limit
- Available in plastic TO-92 and plastic SO-8 low profile packages
- No external components
- Output voltages of 5.0V, 6.2V, 8.2V, 9.0V, 12V, 15V
- See AN-1112 for micro SMD considerations

Connection Diagrams

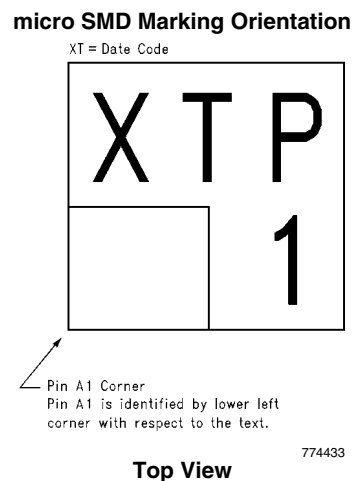
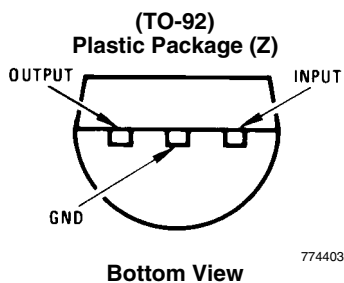
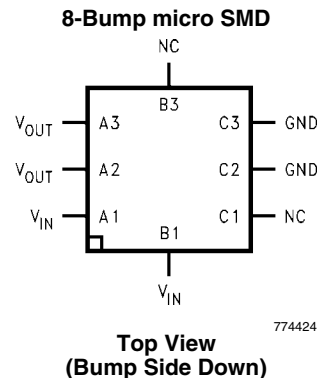
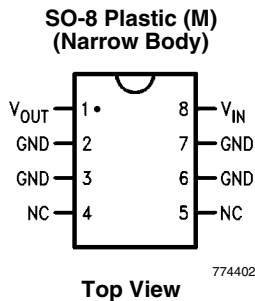

Ordering Information

Package	NSC Drawing	Output Voltage	Order Number	Supplied As
micro SMD	BPA08AAB	5V	LM78L05IBPX	Reel of 3000
Thin micro SMD	TPA08AAA	5V	LM78L05ITP	Reel of 250
			LM78L05ITPX	Reel of 3000
		9V	LM78L09ITPX	Reel of 3000
SOIC Narrow	M08A	5V	LM78L05ACM	Rail of 95
			LM78L05ACMX	Reel of 2500
			LM78L05AIM	Rail of 95
			LM78L05AIMX	Reel of 2500
		12V	LM78L12ACMX	Reel of 2500
		15V	LM78L15ACMX	Reel of 2500
TO-92	Z03A	5V	LM78L05ACZ	Box of 1800
		6.2V	LM78L62ACZ	Box of 1800
		9V	LM78L09ACZ	Box of 1800
		12V	LM78L12ACZ	Box of 1800
		15V	LM78L15ACZ	Box of 1800

Absolute Maximum Ratings (Note 1)

If Military/Aerospace specified devices are required, please contact the National Semiconductor Sales Office/Distributors for availability and specifications.

Power Dissipation (Note 5)	Internally Limited
Input Voltage	35V
Storage Temperature	-65°C to +150°C
ESD Susceptibility (Note 2)	1kV

Operating Junction Temperature	
SO-8, TO-92	0°C to 125°C
SO-8 (5V Only)	-40°C to 125°C
micro SMD	-40°C to 85°C
Soldering Information	
Infrared or Convection (20 sec.)	235°C
Wave Soldering (10 sec.)	260°C (lead time)

LM78LXX Electrical Characteristics Limits in standard typeface are for $T_j = 25^\circ\text{C}$, **Bold typeface applies over the entire operating temperature range of the indicated package.** Limits are guaranteed by production testing or correlation techniques using standard Statistical Quality Control (SQC) methods. Unless otherwise specified: $I_o = 40\text{mA}$, $C_1 = 0.33\mu\text{F}$, $C_o = 0.1\mu\text{F}$.

LM78L05

Unless otherwise specified, $V_{IN} = 10\text{V}$

Symbol	Parameter	Conditions	Min	Typ	Max	Units
V_o	Output Voltage		4.8	5	5.2	V
		$7\text{V} \leq V_{IN} \leq 20\text{V}$ $1\text{mA} \leq I_o \leq 40\text{mA}$ (Note 3)	4.75		5.25	
		$1\text{mA} \leq I_o \leq 70\text{mA}$ (Note 3)	4.75		5.25	
ΔV_o	Line Regulation	$7\text{V} \leq V_{IN} \leq 20\text{V}$		18	75	mV
		$8\text{V} \leq V_{IN} \leq 20\text{V}$		10	54	
ΔV_o	Load Regulation	$1\text{mA} \leq I_o \leq 100\text{mA}$		20	60	mV
		$1\text{mA} \leq I_o \leq 40\text{mA}$		5	30	
I_Q	Quiescent Current			3	5	mA
ΔI_Q	Quiescent Current Change	$8\text{V} \leq V_{IN} \leq 20\text{V}$			1.0	
		$1\text{mA} \leq I_o \leq 40\text{mA}$			0.1	
V_n	Output Noise Voltage	$f = 10\text{ Hz to } 100\text{ kHz}$ (Note 4)		40		μV
$\frac{\Delta V_{IN}}{\Delta V_{OUT}}$	Ripple Rejection	$f = 120\text{ Hz}$ $8\text{V} \leq V_{IN} \leq 16\text{V}$	47	62		dB
I_{PK}	Peak Output Current			140		mA
$\frac{\Delta V_o}{\Delta T}$	Average Output Voltage Tempco	$I_o = 5\text{mA}$		-0.65		$\text{mV}/^\circ\text{C}$
$V_{IN}(\text{Min})$	Minimum Value of Input Voltage Required to Maintain Line Regulation			6.7	7	V
θ_{JA}	Thermal Resistance (8-Bump micro SMD)			230.9		$^\circ\text{C}/\text{W}$

LM78L62ACUnless otherwise specified, $V_{IN} = 12V$

Symbol	Parameter	Conditions	Min	Typ	Max	Units
V_O	Output Voltage		5.95	6.2	6.45	V
		$8.5V \leq V_{IN} \leq 20V$ $1mA \leq I_O \leq 40mA$ (Note 3)	5.9		6.5	
		$1mA \leq I_O \leq 70mA$ (Note 3)	5.9		6.5	
ΔV_O	Line Regulation	$8.5V \leq V_{IN} \leq 20V$		65	175	mV
		$9V \leq V_{IN} \leq 20V$		55	125	
ΔV_O	Load Regulation	$1mA \leq I_O \leq 100mA$		13	80	mV
		$1mA \leq I_O \leq 40mA$		6	40	
I_Q	Quiescent Current			2	5.5	mA
ΔI_Q	Quiescent Current Change	$8V \leq V_{IN} \leq 20V$			1.5	
		$1mA \leq I_O \leq 40mA$			0.1	
V_n	Output Noise Voltage	$f = 10 \text{ Hz to } 100 \text{ kHz}$ (Note 4)		50		μV
$\frac{\Delta V_{IN}}{\Delta V_{OUT}}$	Ripple Rejection	$f = 120 \text{ Hz}$ $10V \leq V_{IN} \leq 20V$	40	46		dB
I_{PK}	Peak Output Current			140		mA
$\frac{\Delta V_O}{\Delta T}$	Average Output Voltage Tempco	$I_O = 5mA$		-0.75		$mV/^\circ C$
$V_{IN} (\text{Min})$	Minimum Value of Input Voltage Required to Maintain Line Regulation			7.9		V

LM78L82ACUnless otherwise specified, $V_{IN} = 14V$

Symbol	Parameter	Conditions	Min	Typ	Max	Units
V_O	Output Voltage		7.87	8.2	8.53	V
		$11V \leq V_{IN} \leq 23V$ $1mA \leq I_O \leq 40mA$ (Note 3)	7.8		8.6	
		$1mA \leq I_O \leq 70mA$ (Note 3)	7.8		8.6	
ΔV_O	Line Regulation	$11V \leq V_{IN} \leq 23V$		80	175	mV
		$12V \leq V_{IN} \leq 23V$		70	125	
ΔV_O	Load Regulation	$1mA \leq I_O \leq 100mA$		15	80	mV
		$1mA \leq I_O \leq 40mA$		8	40	
I_Q	Quiescent Current			2	5.5	mA
ΔI_Q	Quiescent Current Change	$12V \leq V_{IN} \leq 23V$			1.5	
		$1mA \leq I_O \leq 40mA$			0.1	
V_n	Output Noise Voltage	$f = 10 \text{ Hz to } 100 \text{ kHz}$ (Note 4)		60		μV
$\frac{\Delta V_{IN}}{\Delta V_{OUT}}$	Ripple Rejection	$f = 120 \text{ Hz}$ $12V \leq V_{IN} \leq 22V$	39	45		dB
I_{PK}	Peak Output Current			140		mA

Symbol	Parameter	Conditions	Min	Typ	Max	Units
$\frac{\Delta V_O}{\Delta T}$	Average Output Voltage Tempco	$I_O = 5\text{mA}$		-0.8		mV/°C
$V_{IN}(\text{Min})$	Minimum Value of Input Voltage Required to Maintain Line Regulation			9.9		V

LM78L09AC

Unless otherwise specified, $V_{IN} = 15\text{V}$

Symbol	Parameter	Conditions	Min	Typ	Max	Units
V_O	Output Voltage		8.64	9.0	9.36	V
		$11.5\text{V} \leq V_{IN} \leq 24\text{V}$ $1\text{mA} \leq I_O \leq 40\text{mA}$ (Note 3)	8.55		9.45	
		$1\text{mA} \leq I_O \leq 70\text{mA}$ (Note 3)	8.55		9.45	
ΔV_O	Line Regulation	$11.5\text{V} \leq V_{IN} \leq 24\text{V}$		100	200	mV
		$13\text{V} \leq V_{IN} \leq 24\text{V}$		90	150	
ΔV_O	Load Regulation	$1\text{mA} \leq I_O \leq 100\text{mA}$		20	90	mV
		$1\text{mA} \leq I_O \leq 40\text{mA}$		10	45	
I_Q	Quiescent Current			2	5.5	mA
ΔI_Q	Quiescent Current Change	$11.5\text{V} \leq V_{IN} \leq 24\text{V}$			1.5	
		$1\text{mA} \leq I_O \leq 40\text{mA}$			0.1	
V_n	Output Noise Voltage			70		μV
$\frac{\Delta V_{IN}}{\Delta V_{OUT}}$	Ripple Rejection	$f = 120\text{Hz}$ $15\text{V} \leq V_{IN} \leq 25\text{V}$	38	44		dB
I_{PK}	Peak Output Current			140		mA
$\frac{\Delta V_O}{\Delta T}$	Average Output Voltage Tempco	$I_O = 5\text{mA}$		-0.9		mV/°C
$V_{IN}(\text{Min})$	Minimum Value of Input Voltage Required to Maintain Line Regulation			10.7		V

LM78L12AC

Unless otherwise specified, $V_{IN} = 19\text{V}$

Symbol	Parameter	Conditions	Min	Typ	Max	Units
V_O	Output Voltage		11.5	12	12.5	V
		$14.5\text{V} \leq V_{IN} \leq 27\text{V}$ $1\text{mA} \leq I_O \leq 40\text{mA}$ (Note 3)	11.4		12.6	
		$1\text{mA} \leq I_O \leq 70\text{mA}$ (Note 3)	11.4		12.6	
ΔV_O	Line Regulation	$14.5\text{V} \leq V_{IN} \leq 27\text{V}$		30	180	mV
		$16\text{V} \leq V_{IN} \leq 27\text{V}$		20	110	
ΔV_O	Load Regulation	$1\text{mA} \leq I_O \leq 100\text{mA}$		30	100	mV
		$1\text{mA} \leq I_O \leq 40\text{mA}$		10	50	
I_Q	Quiescent Current			3	5	mA
ΔI_Q	Quiescent Current Change	$16\text{V} \leq V_{IN} \leq 27\text{V}$			1	
		$1\text{mA} \leq I_O \leq 40\text{mA}$			0.1	
V_n	Output Noise Voltage			80		μV

Symbol	Parameter	Conditions	Min	Typ	Max	Units
$\frac{\Delta V_{IN}}{\Delta V_{OUT}}$	Ripple Rejection	$f = 120 \text{ Hz}$ $15V \leq V_{IN} \leq 25$	40	54		dB
I_{PK}	Peak Output Current			140		mA
$\frac{\Delta V_O}{\Delta T}$	Average Output Voltage Tempco	$I_O = 5\text{mA}$		-1.0		mV/°C
$V_{IN} \text{ (Min)}$	Minimum Value of Input Voltage Required to Maintain Line Regulation			13.7	14.5	V

LM78L15AC

Unless otherwise specified, $V_{IN} = 23V$

Symbol	Parameter	Conditions	Min	Typ	Max	Units
V_O	Output Voltage		14.4	15.0	15.6	V
		$17.5V \leq V_{IN} \leq 30V$ $1\text{mA} \leq I_O \leq 40\text{mA}$ (Note 3)	14.25		15.75	
		$1\text{mA} \leq I_O \leq 70\text{mA}$ (Note 3)	14.25		15.75	
ΔV_O	Line Regulation	$17.5V \leq V_{IN} \leq 30V$		37	250	mV
		$20V \leq V_{IN} \leq 30V$		25	140	
ΔV_O	Load Regulation	$1\text{mA} \leq I_O \leq 100\text{mA}$		35	150	mV
		$1\text{mA} \leq I_O \leq 40\text{mA}$		12	75	
I_Q	Quiescent Current			3	5	mA
ΔI_Q	Quiescent Current Change	$20V \leq V_{IN} \leq 30V$			1	
		$1\text{mA} \leq I_O \leq 40\text{mA}$			0.1	
V_n	Output Noise Voltage			90		μV
$\frac{\Delta V_{IN}}{\Delta V_{OUT}}$	Ripple Rejection	$f = 120 \text{ Hz}$ $18.5V \leq V_{IN} \leq 28.5V$	37	51		dB
I_{PK}	Peak Output Current			140		mA
$\frac{\Delta V_O}{\Delta T}$	Average Output Voltage Tempco	$I_O = 5\text{mA}$		-1.3		mV/°C
$V_{IN} \text{ (Min)}$	Minimum Value of Input Voltage Required to Maintain Line Regulation			16.7	17.5	V

Note 1: Absolute Maximum Ratings indicate limits beyond which damage to the device may occur. Electrical specifications do not apply when operating the device outside of its stated operating conditions.

Note 2: Human body model, 1.5 k Ω in series with 100pF.

Note 3: Power dissipation $\leq 0.75W$.

Note 4: Recommended minimum load capacitance of 0.01 μF to limit high frequency noise.

Note 5: Typical thermal resistance values for the packages are:

Z Package: $\theta_{JC} = 60 \text{ }^\circ\text{C/W}$, $\theta_{JA} = 230 \text{ }^\circ\text{C/W}$

M Package: $\theta_{JA} = 180 \text{ }^\circ\text{C/W}$

micro SMD Package: $\theta_{JA} = 230.9 \text{ }^\circ\text{C/W}$

Typical Performance Characteristics

Maximum Average Power Dissipation (Z Package)

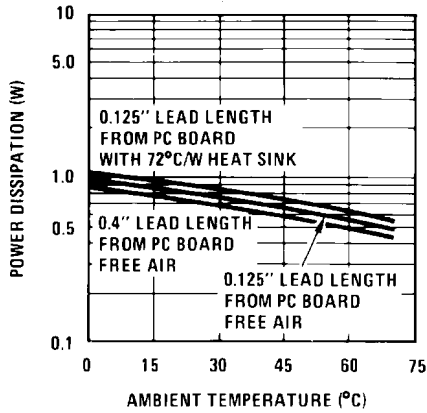

774414

Peak Output Current

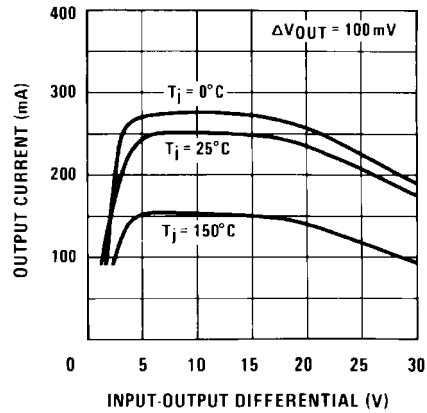

774416

Dropout Voltage

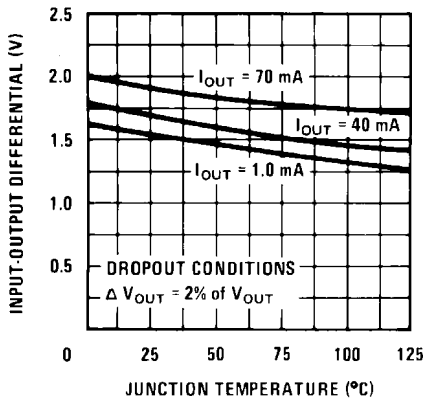

774417

Ripple Rejection

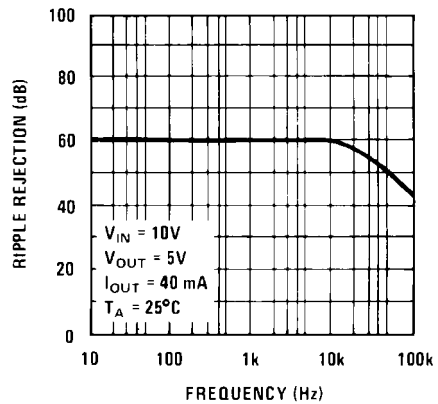

774418

Output Impedance

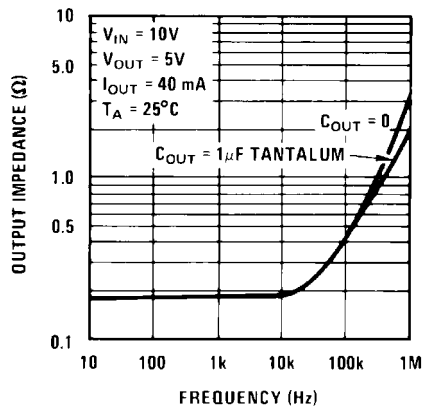

774419

Quiescent Current

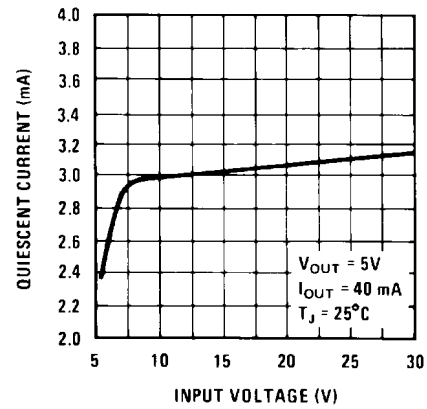

774420

Quiescent Current

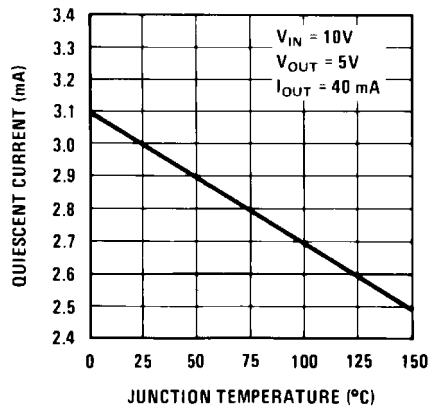

774421

Equivalent Circuit

LM78LXX

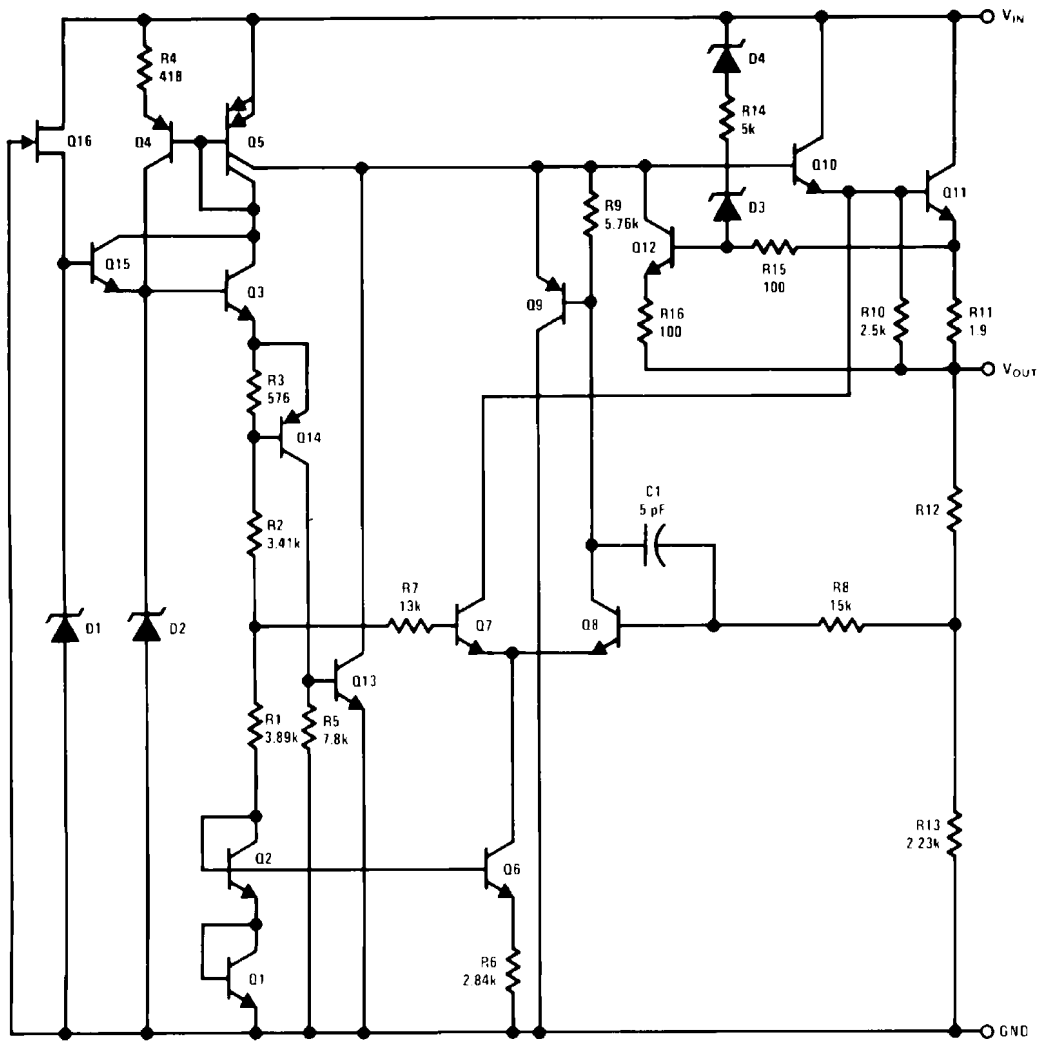

774407

Typical Applications

Fixed Output Regulator

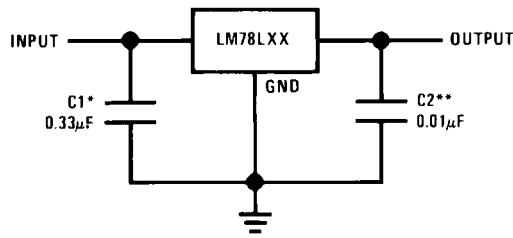

774408

*Required if the regulator is located more than 3' from the power supply filter.

**See (Note 4) in the electrical characteristics table.

Adjustable Output Regulator

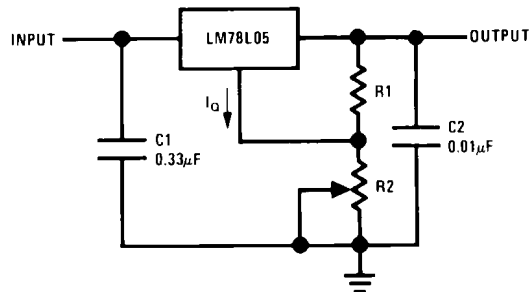

774409

$$V_{OUT} = 5V + (5V/R1 + I_Q) R2$$

$$5V/R1 > 3 I_Q, \text{ load regulation } (L_r) \approx [(R1 + R2)/R1] (L_r \text{ of LM78L05})$$

Current Regulator

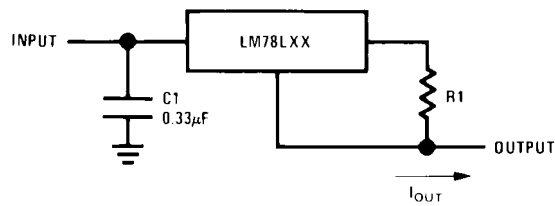

774410

$$I_{OUT} = (V_{OUT}/R1) + I_Q$$

$> I_Q = 1.5\text{mA}$ over line and load changes

5V, 500mA Regulator with Short Circuit Protection

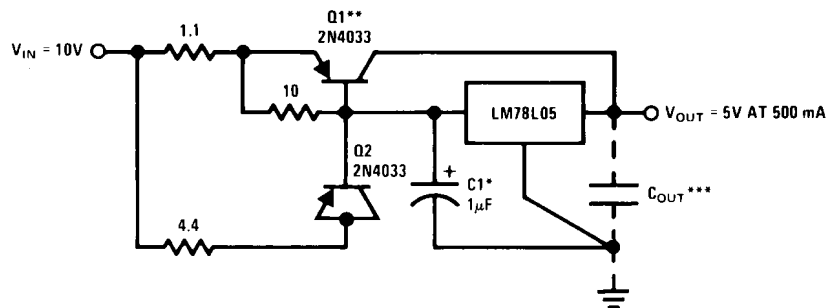

774411

*Solid tantalum.

**Heat sink Q1.

***Optional: Improves ripple rejection and transient response.

Load Regulation: $0.6\% \ 0 \leq I_L \leq 250\text{mA}$ pulsed with $t_{ON} = 50\text{ms}$.

±15V, 100mA Dual Power Supply

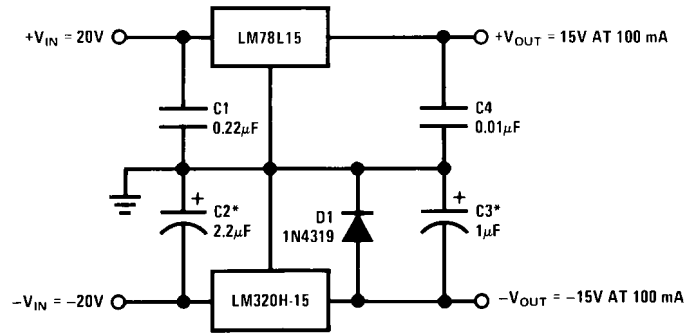

774412

*Solid tantalum.

Variable Output Regulator 0.5V-18V

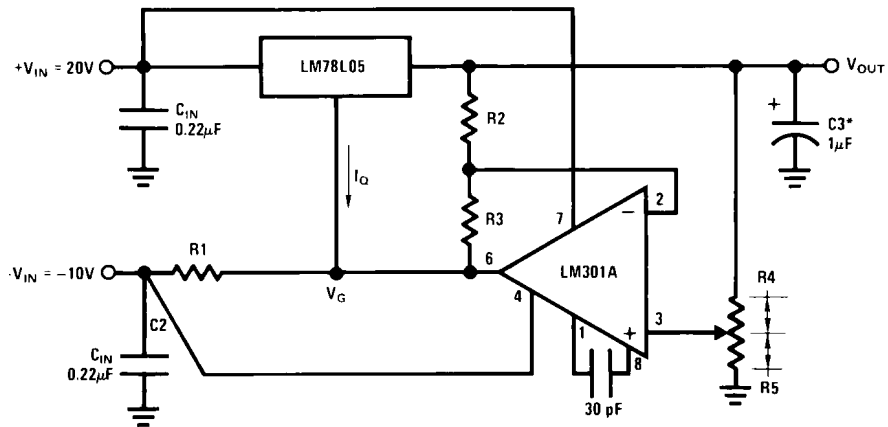

774413

*Solid tantalum.

$$V_{OUT} = V_G + 5V, R1 = (-V_{IN}/I_{Q\ LM78L05})$$

$$V_{OUT} = 5V (R2/R4) \text{ for } (R2 + R3) = (R4 + R5)$$

A 0.5V output will correspond to $(R2/R4) = 0.1$ $(R3/R4) = 0.9$

Physical Dimensions inches (millimeters) unless otherwise noted

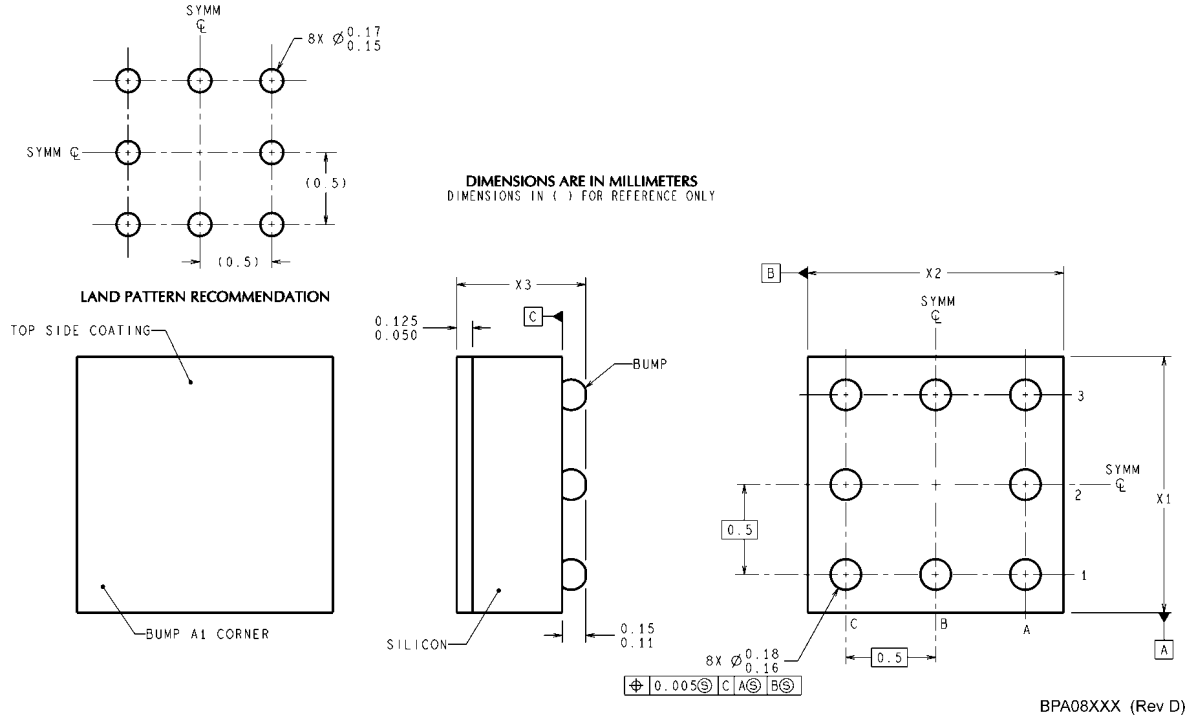

NOTES: UNLESS OTHERWISE SPECIFIED

1. EPOXY COATING
2. 63Sn/37Pb EUTECTIC BUMP
3. RECOMMEND NON-SOLDER MASK DEFINED LANDING PAD.
4. PIN A1 IS ESTABLISHED BY LOWER LEFT CORNER WITH RESPECT TO TEXT ORIENTATION. REMAINING PINS ARE NUMBERED COUNTERCLOCKWISE.
5. XXX IN DRAWING NUMBER REPRESENTS PACKAGE SIZE VARIATION WHERE X₁ IS PACKAGE WIDTH, X₂ IS PACKAGE LENGTH AND X₃ IS PACKAGE HEIGHT.
6. REFERENCE JEDEC REGISTRATION MO-211, VARIATION BC.

8-Bump micro SMD
NS Package Number BPA08AAB
X1 = 1.285mm X2 = 1.285mm X3 = 0.850mm

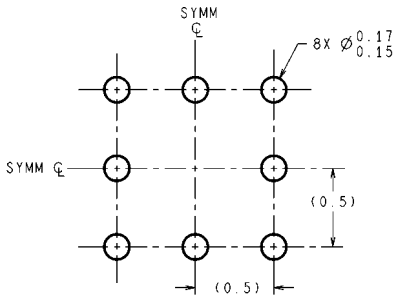

DIMENSIONS ARE IN MILLIMETERS
DIMENSIONS IN () FOR REFERENCE ONLY

LAND PATTERN RECOMMENDATION

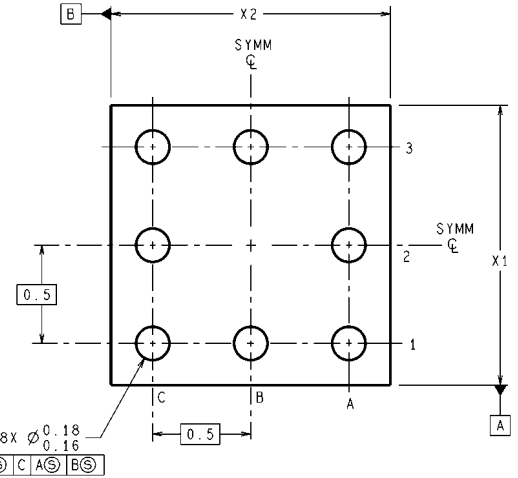
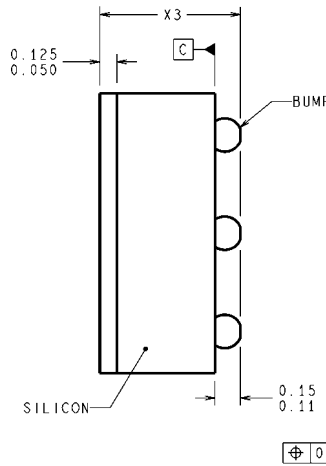
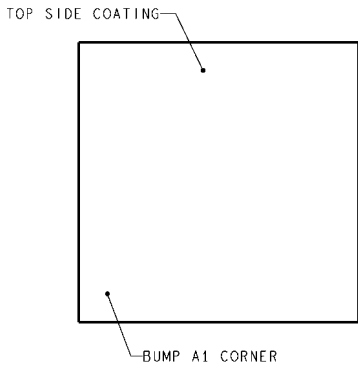

TPA08XXX (Rev B)

8-Bump Thin micro SMD
NS Package Number TPA08AAA
X1 = 1.285mm X2 = 1.285mm X3 = 0.500mm

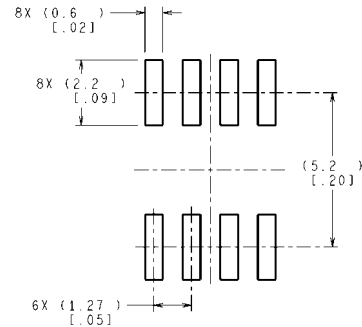
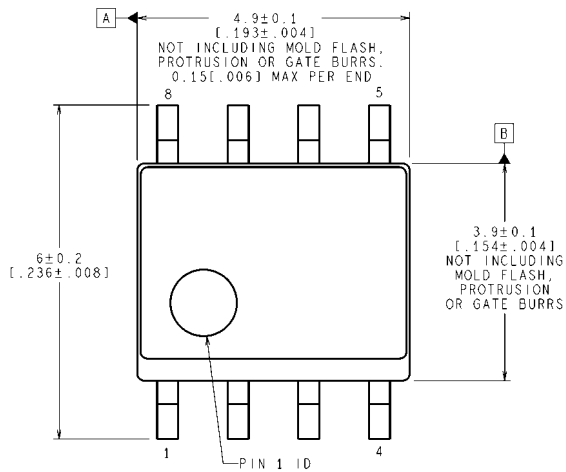

RECOMMENDED LAND PATTERN

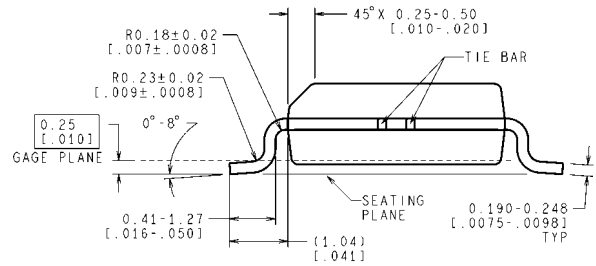
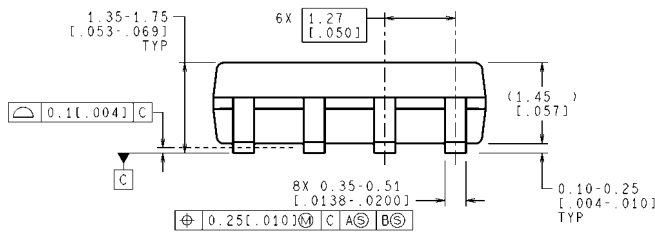

CONTROLLING DIMENSION IS MILLIMETER
VALUES IN [] ARE INCHES
DIMENSIONS IN () FOR REFERENCE ONLY

M08A (Rev M)

S.O. Package (M)
NS Package Number M08A

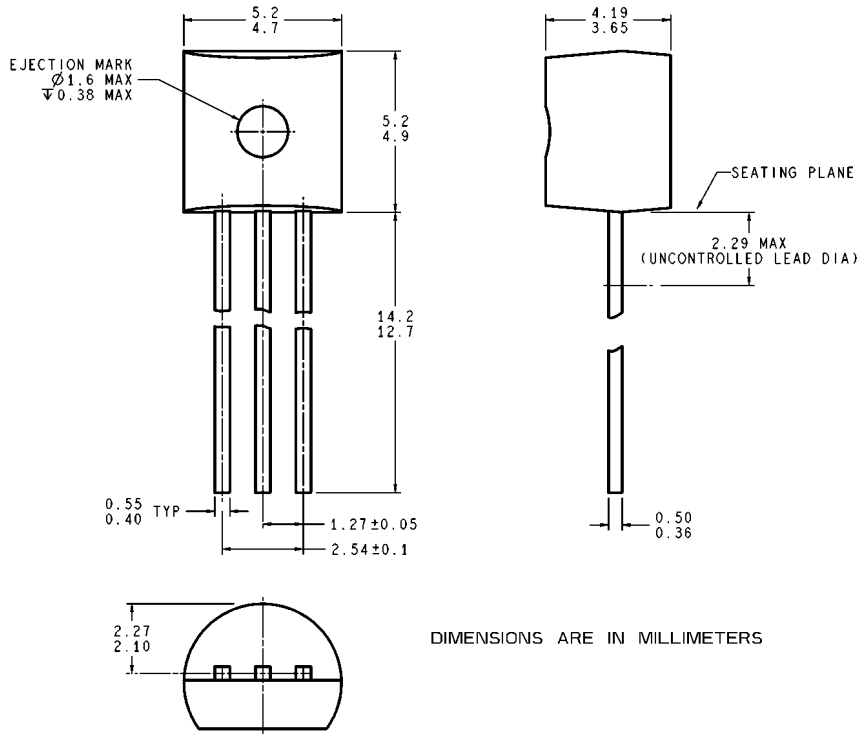

**Molded Offset TO-92 (Z)
 NS Package Number Z03A**

Z03A (Rev G)

Notes

For more National Semiconductor product information and proven design tools, visit the following Web sites at:
www.national.com

Products		Design Support	
Amplifiers	www.national.com/amplifiers	WEBENCH® Tools	www.national.com/webench
Audio	www.national.com/audio	App Notes	www.national.com/appnotes
Clock and Timing	www.national.com/timing	Reference Designs	www.national.com/refdesigns
Data Converters	www.national.com/adc	Samples	www.national.com/samples
Interface	www.national.com/interface	Eval Boards	www.national.com/evalboards
LVDS	www.national.com/lvds	Packaging	www.national.com/packaging
Power Management	www.national.com/power	Green Compliance	www.national.com/quality/green
Switching Regulators	www.national.com/switchers	Distributors	www.national.com/contacts
LDOs	www.national.com/lido	Quality and Reliability	www.national.com/quality
LED Lighting	www.national.com/led	Feedback/Support	www.national.com/feedback
Voltage References	www.national.com/vref	Design Made Easy	www.national.com/easy
PowerWise® Solutions	www.national.com/powerwise	Applications & Markets	www.national.com/solutions
Serial Digital Interface (SDI)	www.national.com/sdi	Mil/Aero	www.national.com/milaero
Temperature Sensors	www.national.com/tempensors	SolarMagic™	www.national.com/solarmagic
PLL/VCO	www.national.com/wireless	PowerWise® Design University	www.national.com/training

THE CONTENTS OF THIS DOCUMENT ARE PROVIDED IN CONNECTION WITH NATIONAL SEMICONDUCTOR CORPORATION ("NATIONAL") PRODUCTS. NATIONAL MAKES NO REPRESENTATIONS OR WARRANTIES WITH RESPECT TO THE ACCURACY OR COMPLETENESS OF THE CONTENTS OF THIS PUBLICATION AND RESERVES THE RIGHT TO MAKE CHANGES TO SPECIFICATIONS AND PRODUCT DESCRIPTIONS AT ANY TIME WITHOUT NOTICE. NO LICENSE, WHETHER EXPRESS, IMPLIED, ARISING BY ESTOPPEL OR OTHERWISE, TO ANY INTELLECTUAL PROPERTY RIGHTS IS GRANTED BY THIS DOCUMENT.

TESTING AND OTHER QUALITY CONTROLS ARE USED TO THE EXTENT NATIONAL DEEMS NECESSARY TO SUPPORT NATIONAL'S PRODUCT WARRANTY. EXCEPT WHERE MANDATED BY GOVERNMENT REQUIREMENTS, TESTING OF ALL PARAMETERS OF EACH PRODUCT IS NOT NECESSARILY PERFORMED. NATIONAL ASSUMES NO LIABILITY FOR APPLICATIONS ASSISTANCE OR BUYER PRODUCT DESIGN. BUYERS ARE RESPONSIBLE FOR THEIR PRODUCTS AND APPLICATIONS USING NATIONAL COMPONENTS. PRIOR TO USING OR DISTRIBUTING ANY PRODUCTS THAT INCLUDE NATIONAL COMPONENTS, BUYERS SHOULD PROVIDE ADEQUATE DESIGN, TESTING AND OPERATING SAFEGUARDS.

EXCEPT AS PROVIDED IN NATIONAL'S TERMS AND CONDITIONS OF SALE FOR SUCH PRODUCTS, NATIONAL ASSUMES NO LIABILITY WHATSOEVER, AND NATIONAL DISCLAIMS ANY EXPRESS OR IMPLIED WARRANTY RELATING TO THE SALE AND/OR USE OF NATIONAL PRODUCTS INCLUDING LIABILITY OR WARRANTIES RELATING TO FITNESS FOR A PARTICULAR PURPOSE, MERCHANTABILITY, OR INFRINGEMENT OF ANY PATENT, COPYRIGHT OR OTHER INTELLECTUAL PROPERTY RIGHT.

LIFE SUPPORT POLICY

NATIONAL'S PRODUCTS ARE NOT AUTHORIZED FOR USE AS CRITICAL COMPONENTS IN LIFE SUPPORT DEVICES OR SYSTEMS WITHOUT THE EXPRESS PRIOR WRITTEN APPROVAL OF THE CHIEF EXECUTIVE OFFICER AND GENERAL COUNSEL OF NATIONAL SEMICONDUCTOR CORPORATION. As used herein:

Life support devices or systems are devices which (a) are intended for surgical implant into the body, or (b) support or sustain life and whose failure to perform when properly used in accordance with instructions for use provided in the labeling can be reasonably expected to result in a significant injury to the user. A critical component is any component in a life support device or system whose failure to perform can be reasonably expected to cause the failure of the life support device or system or to affect its safety or effectiveness.

National Semiconductor and the National Semiconductor logo are registered trademarks of National Semiconductor Corporation. All other brand or product names may be trademarks or registered trademarks of their respective holders.

Copyright© 2011 National Semiconductor Corporation

For the most current product information visit us at www.national.com



National Semiconductor Americas Technical Support Center
 Email: support@nsc.com
 Tel: 1-800-272-9959

National Semiconductor Europe Technical Support Center
 Email: europe.support@nsc.com

National Semiconductor Asia Pacific Technical Support Center
 Email: ap.support@nsc.com

National Semiconductor Japan Technical Support Center
 Email: jpn.feedback@nsc.com