

PQ015YZ5MZxH

PQ015YZ01ZxH

Low Voltage Operation
Low Power-Loss Voltage Regulators

■ Features

- 1.Low voltage operation (Minimum operating voltage: 1.7V)
1.8V input → available 1.0 to 1.5V
- 2.Variable output voltage type
- 3.Surface mount package (equivalent to EIAJ SC-63)
- 4.RoHS directive compliant

■ Applications

- 1.Peripheral equipment of personal computers
- 2.Power supplies for various electronic equipment such as DVD player or STB

■ Model Line-up

Output current (I _o)	Package type	Model No.
0.5A	Taping	PQ015YZ5MZPH
	Sleeve	PQ015YZ5MZZH
1A	Taping	PQ015YZ01ZPH
	Sleeve	PQ015YZ01ZZH

■ Absolute Maximum Ratings (Ta=25°C)

Parameter	Symbol	Rating	Unit
*1 Input voltage	V _{IN}	3.7	V
Bias supply voltage	V _B	7	V
*1 Output adjustment terminal voltage	V _{ADJ}	5	V
Output current	PQ015YZ5MZxH	0.5	A
	PQ015YZ01ZxH	1	
*2 Power dissipation	P _D	8	W
*3 Junction temperature	T _j	150	°C
Operating temperature	T _{opr}	-25 to +85	°C
Storage temperature	T _{stg}	-40 to +150	°C
Soldering temperature	T _{sol}	260(10s)	°C

*1 All are open except GND and applicable terminals.
*2 P_D: With infinite heat sink
*3 Overheat protection may operate at T_j:125°C to 150°C

■ Outline Dimensions

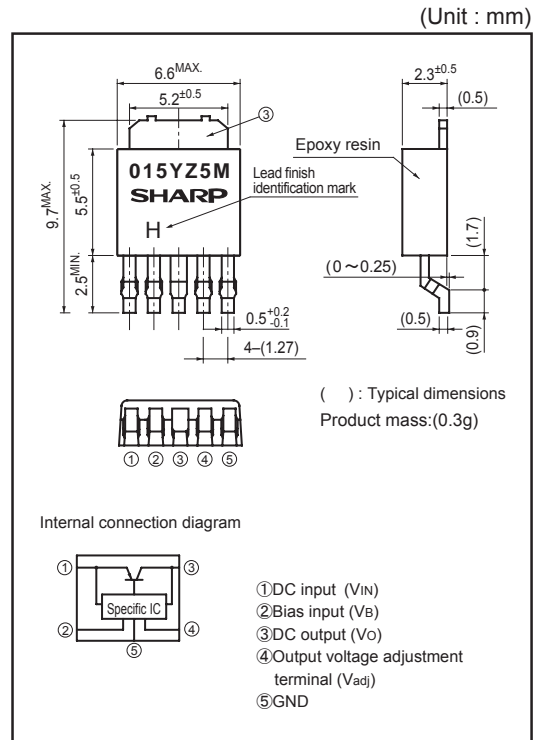

Lead finish:Lead-free solder plating
(Composition: Sn2Cu)

Notice The content of data sheet is subject to change without prior notice.
In the absence of confirmation by device specification sheets, SHARP takes no responsibility for any defects that may occur in equipment using any SHARP devices shown in catalogs, data books, etc. Contact SHARP in order to obtain the latest device specification sheets before using any SHARP device.

Electrical Characteristics

(Unless otherwise specified, condition shall be $V_{IN}=1.8V, V_B=3.3V, V_O=1.2V(R_1=1k\Omega), I_O=0.3A, T_a=25^\circ C$ (PQ015YZ5MZxH))
 (Unless otherwise specified, condition shall be $V_{IN}=1.8V, V_B=3.3V, V_O=1.2V(R_1=1k\Omega), I_O=0.5A, T_a=25^\circ C$ (PQ015YZ01ZxH))

Parameter	Symbol	Conditions	MIN.	TYP.	MAX.	Unit
Input voltage	V_{IN}	On condition that $1.0V \leq V_O \leq 1.2V$	1.7	—	3.7	V
		On condition that $1.2V < V_O \leq 1.5V$	$V_O + 0.5$	—	3.7	
Bias supply voltage	V_B	—	2.35	—	7	V
Output voltage	V_O	—	1.0	—	1.5	V
Load regulation	RegL	$I_O=5mA$ to 0.5A	—	0.2	1.0	%
		$I_O=5mA$ to 1A				
Line regulation	RegL	$V_{IN}=1.7$ to $3.7V, V_B=2.35$ to $7V, I_O=5mA$	—	0.2	1.0	%
Ripple Rejection	RR1	Refer to Fig.2	—	65	—	dB
	RR2	Refer to Fig.3	—	60	—	dB
Reference voltage	V_{REF}	—	0.97	1.0	1.03	V
Temperature coefficient of reference voltage	$T_C V_{REF}$	$T_j=0$ to $125^\circ C, I_O=5mA$	—	± 0.5	—	%
Bias inflow current	I_B	—	—	1.5	3.0	mA

Fig.1 Test Circuit

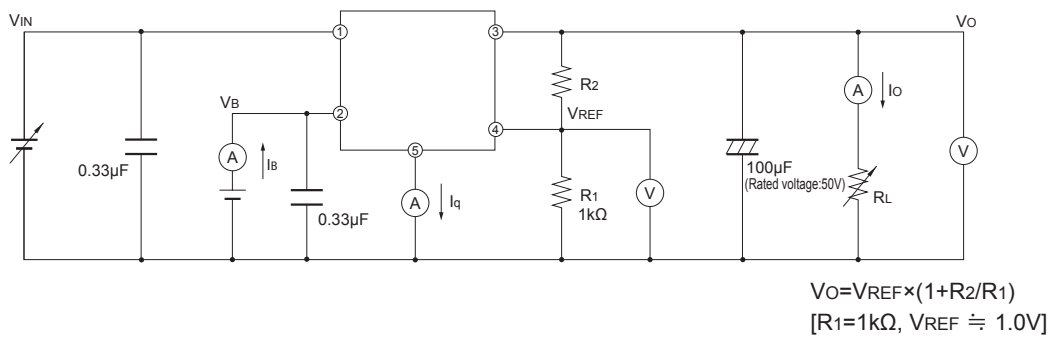

Fig.2 Test Circuit for Ripple Rejection (1)

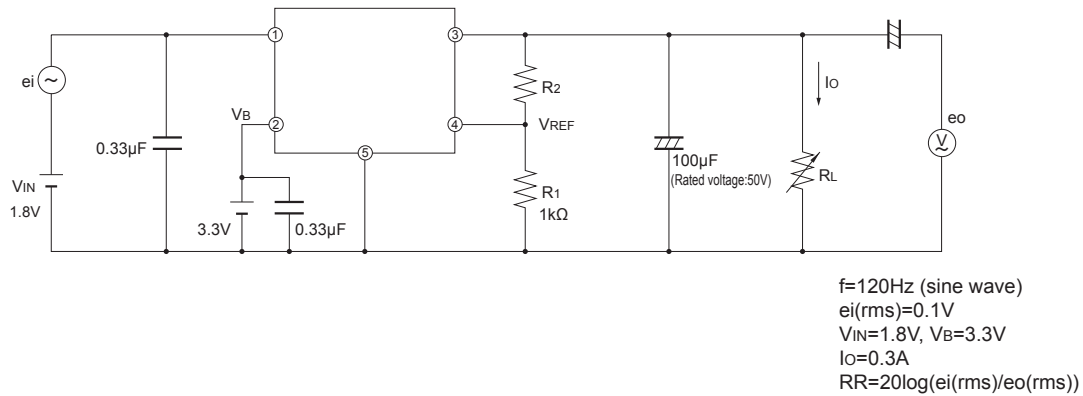
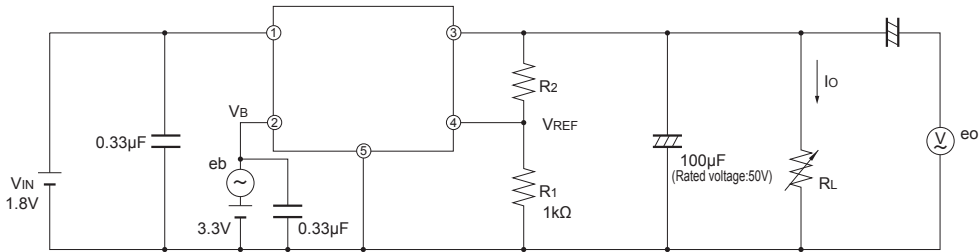
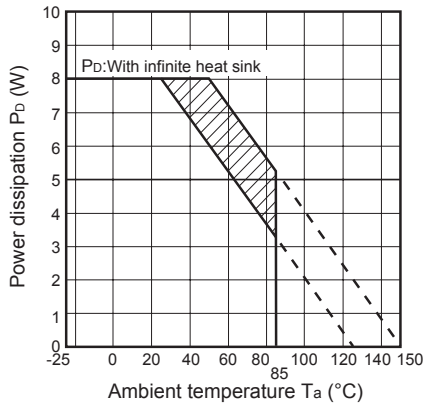

Fig.3 Test Circuit for Ripple Rejection (2)



$f=120\text{Hz}$ (sine wave)
 $e_i(\text{rms})=0.1\text{V}$
 $V_{IN}=1.8\text{V}, V_B=3.3\text{V}$
 $I_o=0.3\text{A}$
 $RR=20\log(e_i(\text{rms})/e_o(\text{rms}))$

Fig.4 Power Dissipation vs. Ambient Temperature



Note) Oblique line portion: Overheat protection may operate in this area.

Fig.5 Overcurrent Protection Characteristics (PQ015YZ5MZxH)

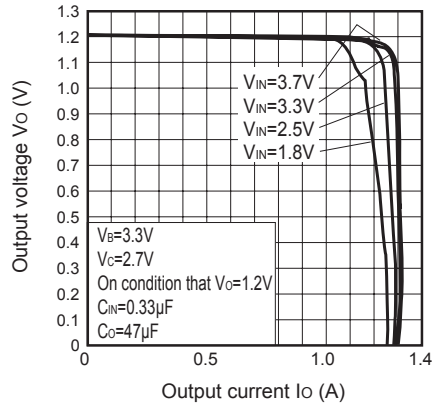

Fig.6 Overcurrent Protection Characteristics (PQ015YZ01ZxH)

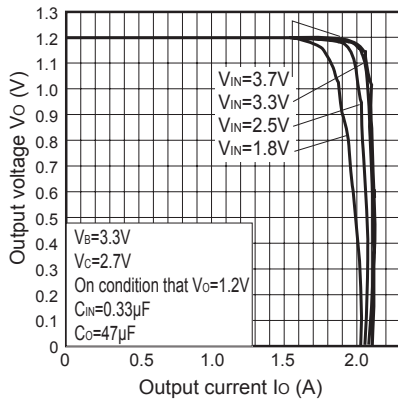

Fig.7 Reference Voltage vs. Ambient Temperature

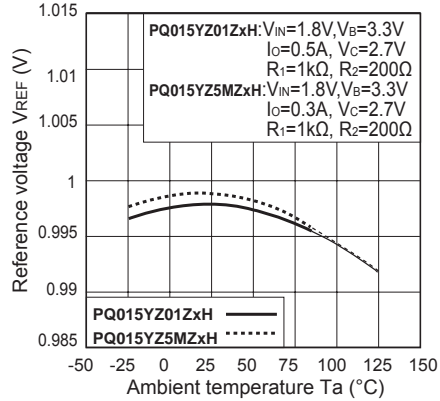

Fig.8 Bias Inflow Current vs. Ambient Temperature

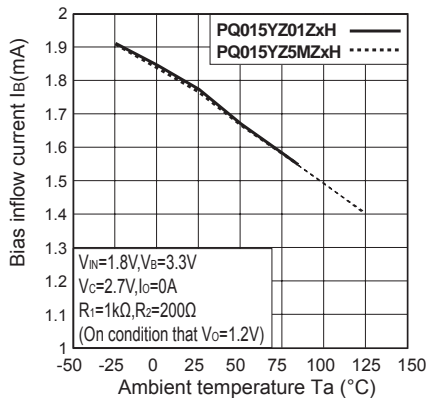

Fig.9 Output Short-circuit Current vs. Ambient Temperature (Reference)

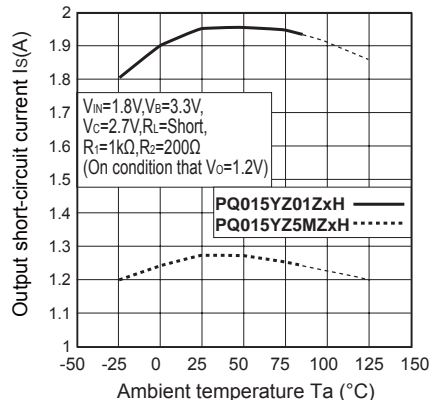

Fig.10 Output Voltage vs. Input Voltage (PQ015YZ5MZxH)

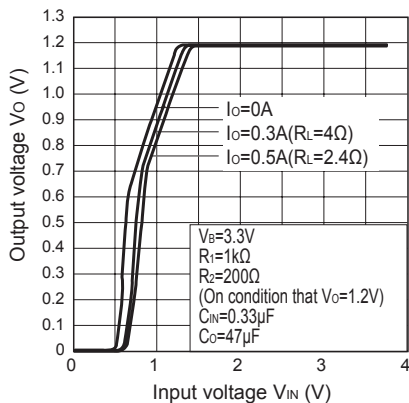

Fig.11 Output Voltage vs. Input Voltage (PQ015YZ01ZxH)

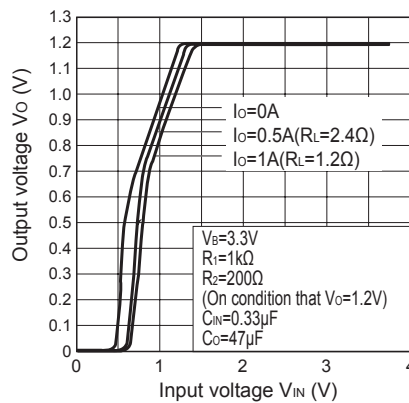

Fig.12 Output Voltage vs. Bias Supply Voltage (PQ015YZ5MZxH)

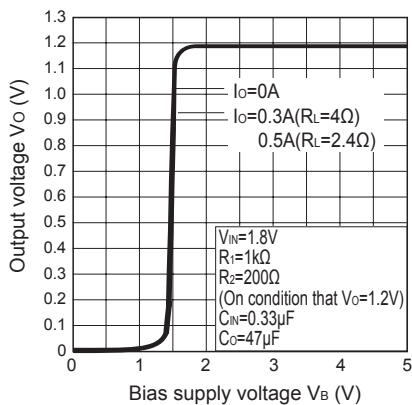

Fig.13 Output Voltage vs. Bias Supply Voltage (PQ015YZ01ZxH)

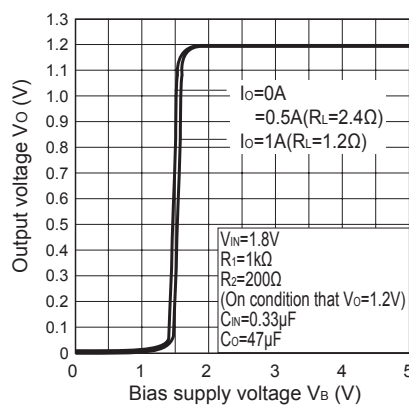

Fig.14 Circuit Operating Current vs. Input Voltage / Bias Supply Voltage (PQ015YZ5MZxH)

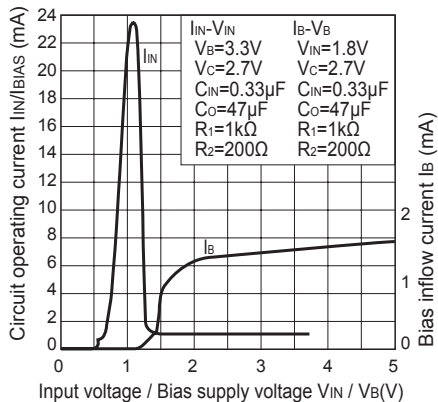

Fig.15 Circuit Operating Current vs. Input Voltage / Bias Supply Voltage (PQ015YZ5MZxH)

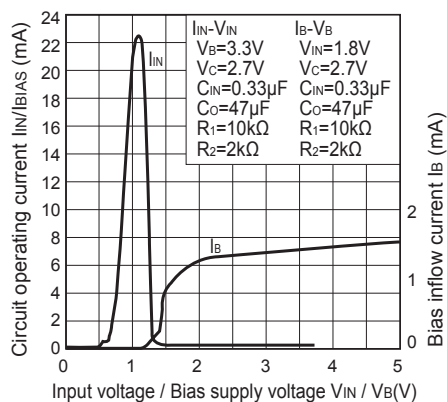

Fig.16 Circuit Operating Current vs. Input Voltage / Bias Supply Voltage (PQ015YZ01ZxH)

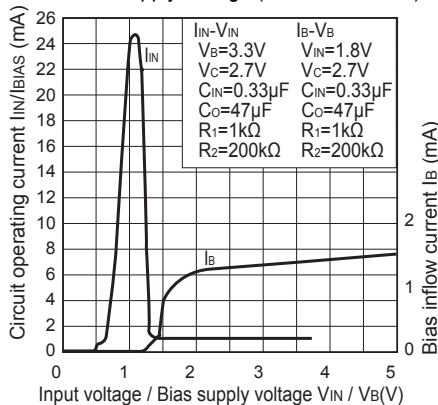

Fig.17 Output Voltage Deviation vs. Input Voltage / Bias Supply Voltage (PQ015YZ5MZxH)

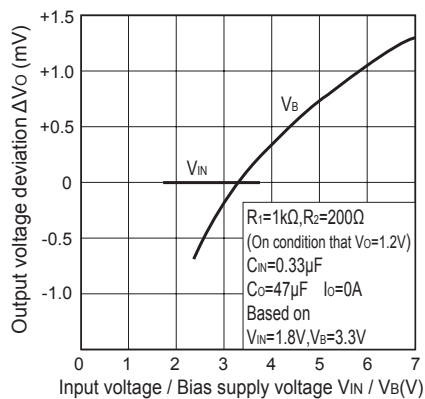

Fig.18 Output Voltage Deviation vs. Input Voltage / Bias Supply Voltage (PQ015YZ01ZxH)

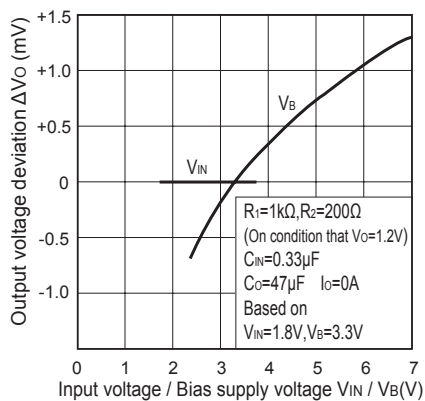

Fig.19 Output Voltage Deviation vs. Output Current

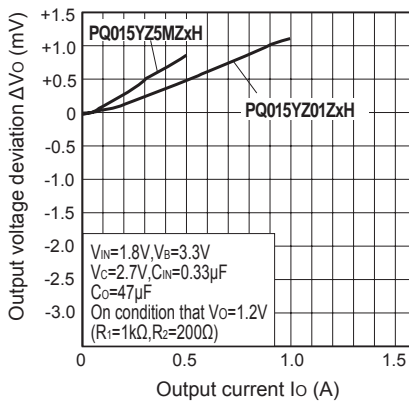

Fig.20 Ripple Rejection vs. Input Ripple Frequency

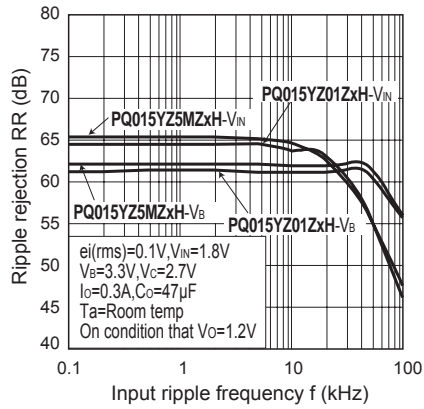

Fig.21 Ripple Rejection vs. Output Current

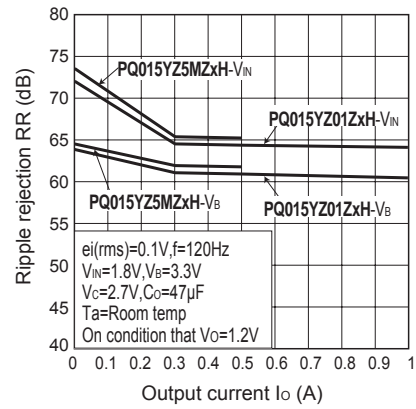

Fig.22 Typical Application

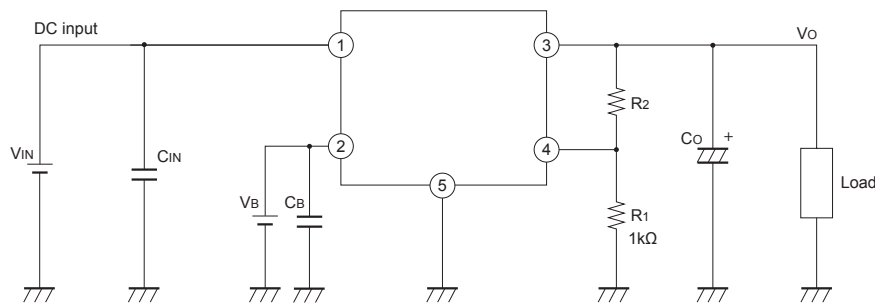
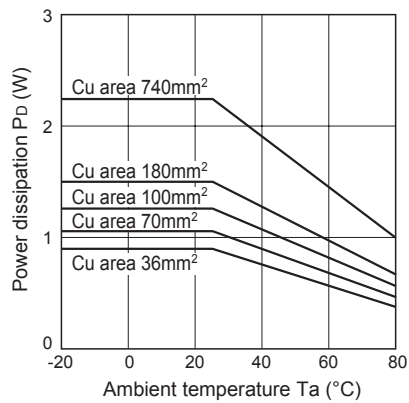
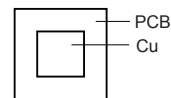

Fig.23 Power Dissipation vs. Ambient Temperature (Typical Value)



Mounting PCB



Material : Glass-cloth epoxy resin
 Size : 50×50×1.6mm
 Cu thickness : 35μm

Fig.24 Output Voltage Adjustment Characteristics (Typical Value)

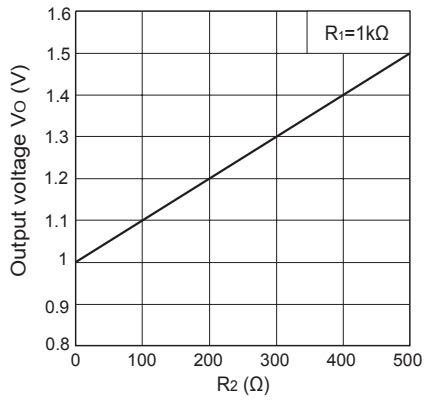

■ Setting of Output Voltage

Output voltage is able to set from 1.0V to 1.5V when resistors R1 and R2 are attached to ③,④,⑤ terminals. As for the external resistors to set output voltage, refer to the figure below and Fig.24.

