



LM2931XX, LM2931AXX33 LM2931AXX50

Very low drop voltage regulators with inhibit function

Features

- Very low dropout voltage (0.15 V typ. at 10 mA load)
- Low quiescent current (typ. 2.5 mA, at 100 mA load)
- Output current up to 100 mA
- Adjustable (from $V_{OUT} = 2.5$ V only SO-8) and fixed (3.3 V and 5 V) output voltage version
- Internal current and thermal limit
- Load dump protection up to 60 V
- Reverse transient protection up to -50 V
- Temperature range: -40 to 125 °C
- Package available: TO-92, DPAK, SO-8 (with inhibit control)

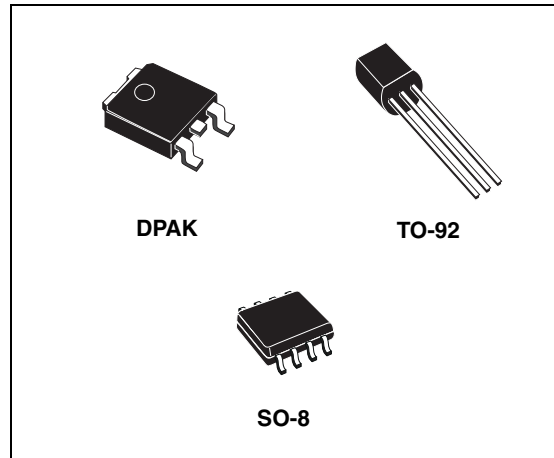

input voltage can exceed the specified maximum operating input voltage of 26 V, the regulator automatically shuts down to protect both internal circuitry and the load.

Description

The LM2931xx are very low drop regulators. The very low drop voltage and the low quiescent current make them particularly suitable for low noise, low power applications and in battery-powered systems. In the 8-pin configuration (SO-8), fully compatible with the older L78Lxx family, a shutdown logic control function is available.

This means that when the device is used as a local regulator it is possible to put a part of the board in standby, decreasing total power consumption. Ideal for automotive applications, LM2931xx is protected from reverse battery installations or 2 battery jumps. During the transient, such as a 60 V load dump, when the

Table 1. Device summary

Order codes			Output voltages
DPAK	TO-92 (Bag)	SO-8	
		LM2931AD33R	3.3 V
LM2931ADT50R	LM2931AZ50R	LM2931AD50R	5.0 V
		LM2931D-R	2.5 to 26 V

Contents

1	Diagram	3
2	Pin configuration	4
3	Maximum ratings	5
4	Application circuits	6
5	Electrical characteristics	7
6	Typical characteristics	10
7	Package mechanical data	14
8	Revision history	20

1 Diagram

Figure 1. Schematic diagram

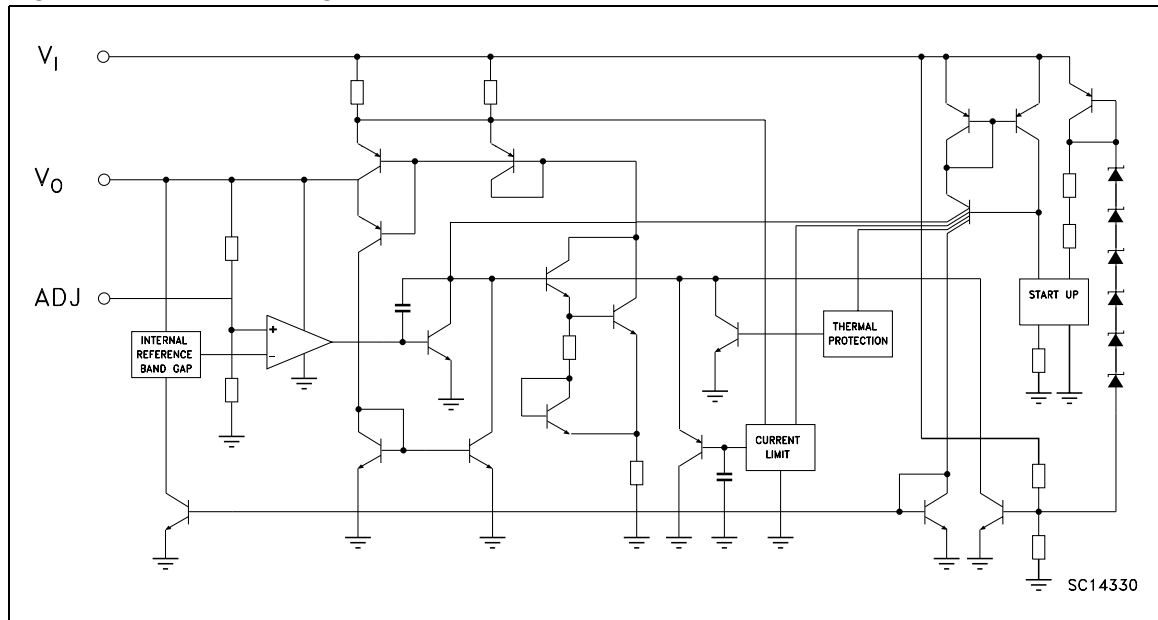

2 Pin configuration

Figure 2. Pin connections (top view)

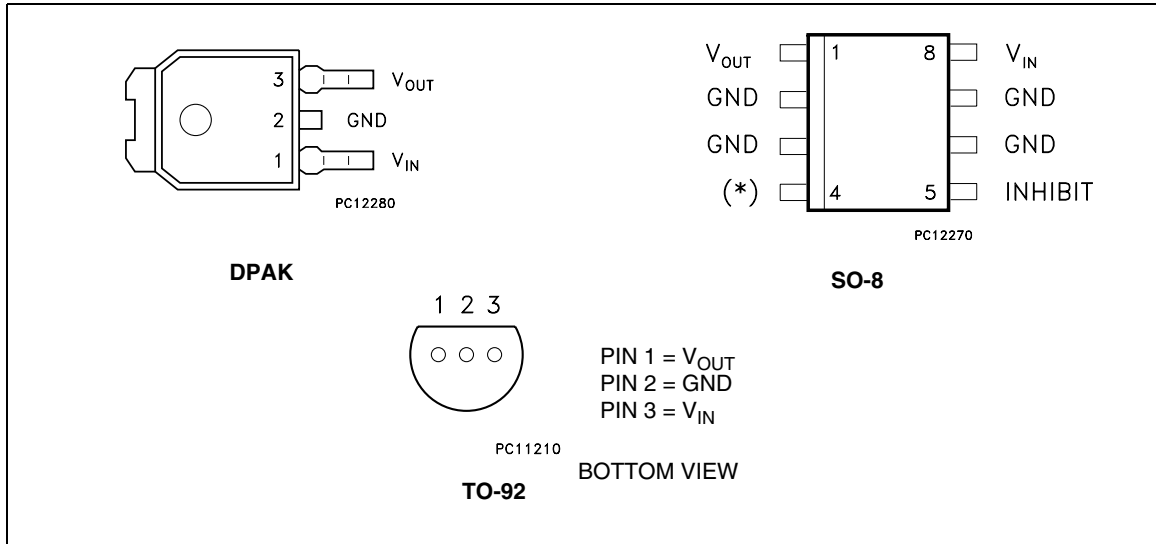

3 Maximum ratings

Table 2. Absolute maximum ratings

Symbol	Parameter	Value	Unit
V_I	DC positive input voltage	40	V
V_I	DC reverse input voltage	-15	V
V_I	Transient input voltage ($\tau < 100$ ms)	60	V
V_I	Transient reverse input voltage ($\tau < 100$ ms)	-50	V
V_{INH}	Inhibit input voltage	40	V
I_O	Output current	Internally limited	
T_{STG}	Storage temperature range	-65 to 150	°C
T_{OP}	Operating junction temperature range	-40 to 125	°C

Note: Absolute maximum ratings are those values beyond which damage to the device may occur. Functional operation under these condition is not implied.

Table 3. Thermal data

Symbol	Parameter	SO-8	DPAK	TO-92	Unit
R_{thJC}	Thermal resistance junction-case	20	8		°C/W
R_{thJA}	Thermal resistance junction-ambient	55 ⁽¹⁾	100	200	°C/W

1. Considering 6 cm² of copper board heat-sink.

4 Application circuits

Figure 3. Application circuit for fixed output

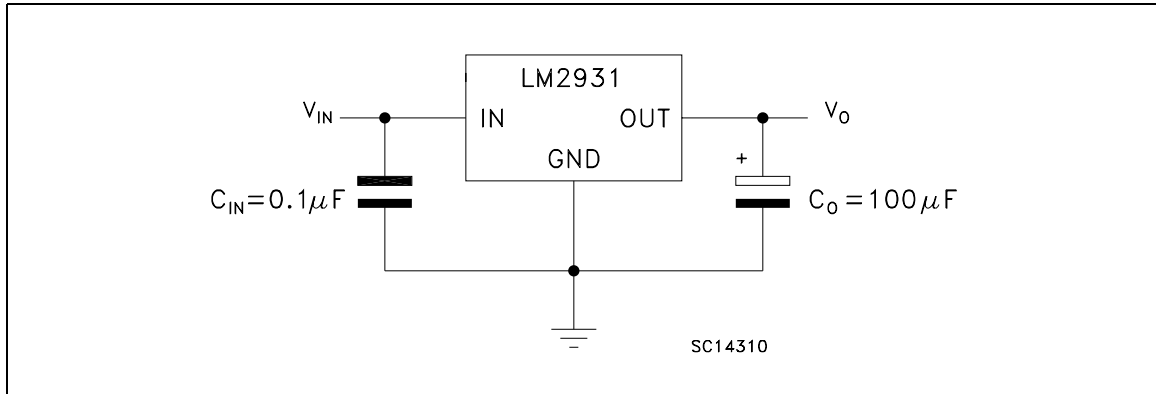
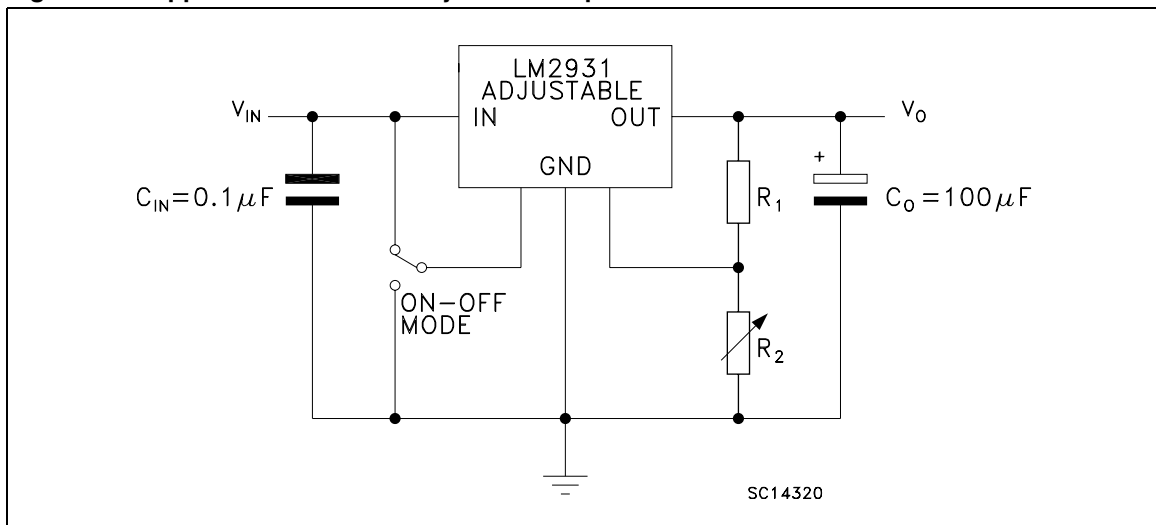

Figure 4. Application circuit for adjustable output



Note: R_1 suggested value = 27 k Ω

$$V_O = V_{REF} (R_1 + R_2) / R_1$$

5 Electrical characteristics

Refer to the application circuit [Figure 3](#), $T_J = 25\text{ }^\circ\text{C}$, $C_I = 0.1\text{ }\mu\text{F}$, $C_O = 100\text{ }\mu\text{F}$, $V_I = 14\text{ V}$, $I_O = 10\text{ mA}$, $V_{INH} = 0\text{ V}$, unless otherwise specified.

Table 4. Electrical characteristics of LM2931Axx33

Symbol	Parameter	Test conditions	Min.	Typ.	Max.	Unit
V_I	Maximum operating input voltage	$I_O = 10\text{ mA}$, $T_J = -40\text{ to }125\text{ }^\circ\text{C}$	26			V
V_O	Output voltage		3.135	3.3	3.425	V
V_O	Output voltage	$I_O = 100\text{ mA}$, $V_I = 6\text{ to }26\text{ V}$ $T_J = -40\text{ to }125\text{ }^\circ\text{C}$	3.135	3.3	3.465	V
ΔV_O	Line regulation	$V_I = 9\text{ to }16\text{ V}$		2	10	mV
		$V_I = 6\text{ to }26\text{ V}$		4	33	
ΔV_O	Load regulation	$I_O = 5\text{ to }100\text{ mA}$		10	33	mV
V_d	Dropout voltage ^{(1) (2)}	$I_O = 10\text{ mA}$		90	250	mV
		$I_O = 100\text{ mA}$		250	600	
I_d	Quiescent current ON MODE	$I_O = 100\text{ mA}$		2.5	30	mA
	OFF MODE	$V_{INH} = 2.5\text{ V}$, $R_{LOAD} = 330\text{ }\Omega$		0.3	1	mA
I_{SC}	Short circuit current		100	300		mA
SVR	Supply voltage rejection	$I_O = 100\text{ mA}$, $V_I = 14 \pm 2\text{ V}$ $f = 120\text{ Hz}$, $T_J = -40\text{ to }125\text{ }^\circ\text{C}$	55	78		dB
V_{IL}	Control input voltage low	$T_J = -40\text{ to }125\text{ }^\circ\text{C}$		2	1.2	V
V_{IH}	Control input voltage high	$T_J = -40\text{ to }125\text{ }^\circ\text{C}$	3.25	2		V
I_{INH}	Inhibit input current	$V_{INH} = 2.5\text{ V}$		22	50	μA
V_I	Transient input voltage	$R_{LOAD} = 330\text{ }\Omega$, $\tau < 100\text{ ms}$	60	70		V
V_I	Reverse polarity input voltage	$V_O = \pm 0.3\text{ V}$, $R_{LOAD} = 330\text{ }\Omega$	-15	-50		V
V_I	Reverse polarity input voltage transient	$R_{LOAD} = 330\text{ }\Omega$, $\tau < 100\text{ ms}$	-50			V
eN	Output noise voltage	$B = 10\text{ Hz to }100\text{ kHz}$		330		μV_{RMS}

1. Reference voltage is measured from V_{OUT} to ADJ pin.

2. V_d measured when the output voltage has dropped 100 mV from the nominal value obtained at 14 V.

Refer to the application circuit [Figure 3](#), $T_J = 25\text{ }^\circ\text{C}$, $C_I = 0.1\text{ }\mu\text{F}$, $C_O = 100\text{ }\mu\text{F}$, $V_I = 14\text{ V}$, $I_O = 10\text{ mA}$, $V_{INH} = 0\text{ V}$, unless otherwise specified.

Table 5. Electrical characteristics of LM2931Axx50

Symbol	Parameter	Test conditions	Min.	Typ.	Max.	Unit
V_I	Maximum operating input voltage	$I_O = 10\text{ mA}$, $T_J = -40\text{ to }125\text{ }^\circ\text{C}$	26			V
V_O	Output voltage		4.81	5	5.19	V
V_O	Output voltage	$I_O = 100\text{ mA}$, $V_I = 6\text{ to }26\text{ V}$ $T_J = -40\text{ to }125\text{ }^\circ\text{C}$	4.75	5	5.25	V
ΔV_O	Line regulation	$V_I = 9\text{ to }16\text{ V}$		2	10	mV
		$V_I = 6\text{ to }26\text{ V}$		4	30	
ΔV_O	Load regulation	$I_O = 5\text{ to }100\text{ mA}$		15	50	mV
V_d	Dropout voltage ^{(1) (2)}	$I_O = 10\text{ mA}$		90	200	mV
		$I_O = 100\text{ mA}$		250	600	
I_d	Quiescent current ON MODE	$I_O = 100\text{ mA}$		2.5	30	mA
	OFF MODE	$V_{INH} = 2.5\text{ V}$, $R_{LOAD} = 500\text{ }\Omega$		0.3	1	mA
I_{SC}	Short circuit current		100	300		mA
SVR	Supply voltage rejection	$I_O = 100\text{ mA}$, $V_I = 14 \pm 2\text{ V}$ $f = 120\text{ Hz}$, $T_J = -40\text{ to }125\text{ }^\circ\text{C}$	55	75		dB
V_{IL}	Control input voltage low	$T_J = -40\text{ to }125\text{ }^\circ\text{C}$		2	1.2	V
V_{IH}	Control input voltage high	$T_J = -40\text{ to }125\text{ }^\circ\text{C}$	3.25	2		V
I_{INH}	Inhibit input current	$V_{INH} = 2.5\text{ V}$		22	50	μA
V_I	Transient input voltage	$R_{LOAD} = 500\text{ }\Omega$, $\tau < 100\text{ ms}$	60	70		V
V_I	Reverse polarity input voltage	$V_O = \pm 0.3\text{ V}$, $R_{LOAD} = 500\text{ }\Omega$	-15	-50		V
V_I	Reverse polarity input voltage transient	$R_{LOAD} = 500\text{ }\Omega$, $\tau < 100\text{ ms}$	-50			V
eN	Output noise voltage	$B = 10\text{ Hz to }100\text{ kHz}$		500		μV_{RMS}

1. Reference voltage is measured from V_{OUT} to ADJ pin.

2. V_d measured when the output voltage has dropped 100 mV from the nominal value obtained at 14 V.

Refer to the application circuit [Figure 4](#) with $R_1 = 27\text{ k}\Omega$ and $R_2 = 40.5\text{ k}\Omega$, $T_J = 25\text{ }^\circ\text{C}$, $C_1 = 0.1\text{ }\mu\text{F}$, $C_O = 100\text{ }\mu\text{F}$, $V_I = 14\text{ V}$, $I_O = 10\text{ mA}$, $V_{INH} = 0\text{ V}$, unless otherwise specified.

Table 6. Electrical characteristics of LM2931xx

Symbol	Parameter	Test conditions	Min.	Typ.	Max.	Unit
V_I	Maximum operating input voltage	$I_O = 10\text{ mA}$, $T_J = -40\text{ to }125^\circ\text{C}$	26			V
V_{REF}	Reference voltage ⁽¹⁾		1.14	1.2	1.26	V
V_{REF}	Reference voltage ⁽¹⁾	$I_O = 100\text{ mA}$, $T_J = -40\text{ to }125^\circ\text{C}$	1.08	1.2	1.32	V
ΔV_O	Line regulation	$V_I = 3.6\text{ to }26\text{ V}$		0.6	4.5	mV
ΔV_O	Load regulation	$I_O = 5\text{ to }100\text{ mA}$		9	30	mV
V_d	Dropout voltage ^{(1) (2)}	$I_O = 10\text{ mA}$		90	200	mV
		$I_O = 100\text{ mA}$		250	600	
I_d	Quiescent current ON MODE	$I_O = 100\text{ mA}$		2.5	30	mA
	OFF MODE	$V_{INH} = 2.5\text{ V}$, $R_{LOAD} = 300\text{ }\Omega$		0.3	1	mA
I_{SC}	Short circuit current		100	300		mA
SVR	Supply voltage rejection	$I_O = 100\text{ mA}$, $V_I = 14 \pm 2\text{ V}$ $f = 120\text{ Hz}$, $T_J = -40\text{ to }125^\circ\text{C}$	55	80		dB
V_{IL}	Control input voltage low	$T_J = -40\text{ to }125^\circ\text{C}$		2	1.2	V
V_{IH}	Control input voltage high	$T_J = -40\text{ to }125^\circ\text{C}$	3.25	2		V
I_{INH}	Inhibit input current	$V_{INH} = 2.5\text{ V}$		22	50	μA
V_I	Transient input voltage	$R_{LOAD} = 300\text{ }\Omega$, $\tau < 100\text{ms}$	60	70		V
V_I	Reverse polarity input voltage	$V_O = \pm 0.3\text{ V}$, $R_{LOAD} = 300\text{ }\Omega$	-15	-50		V
V_I	Reverse polarity input voltage transient	$R_{LOAD} = 300\text{ }\Omega$, $\tau < 100\text{ms}$	-50			V
eN	Output noise voltage	$B = 10\text{ Hz to }100\text{ kHz}$		330		μV_{RMS}

1. Reference voltage is measured from V_{OUT} to ADJ pin.

2. V_d measured when the output voltage has dropped 100 mV from the nominal value obtained at 14 V.

6 Typical characteristics

Unless otherwise specified $C_I = 0.1 \mu\text{F}$, $C_O = 100 \mu\text{F}$.

Figure 5. Output voltage vs. temperature

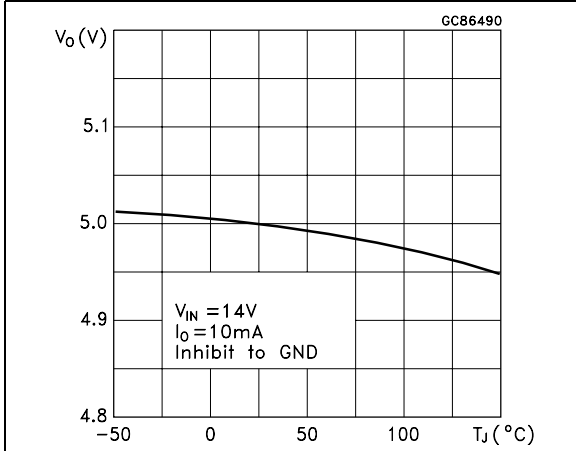

Figure 6. Output voltage vs. temperature

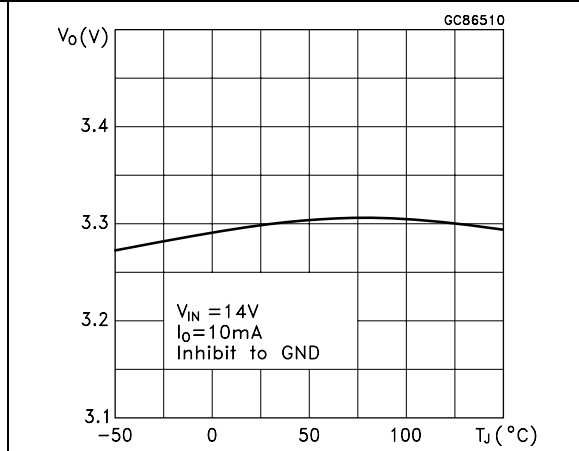

Figure 7. Reference voltage vs. temperature

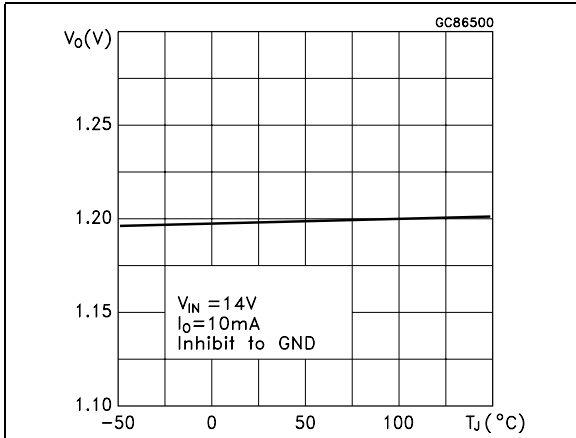

Figure 8. Line regulation vs. temperature

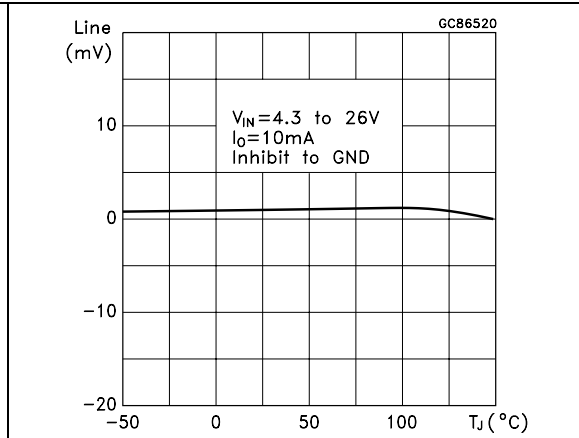

Figure 9. Load regulation vs. temperature

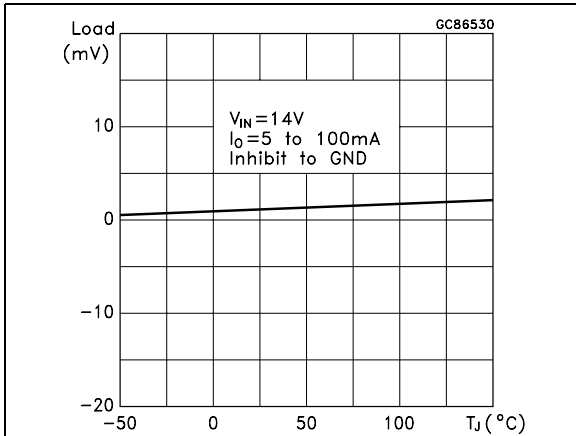

Figure 10. Dropout voltage vs. temperature

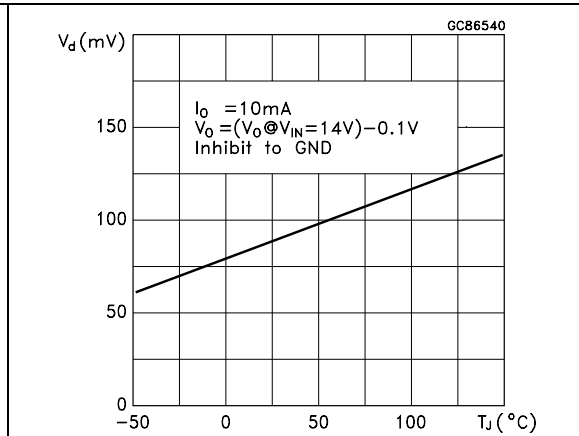

Figure 11. Dropout voltage vs. temperature

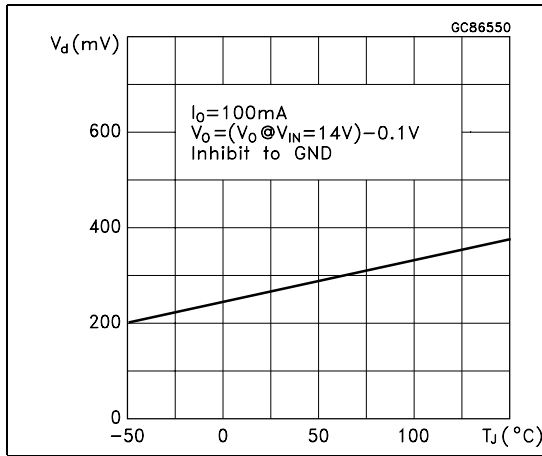

Figure 12. Dropout voltage vs. output current

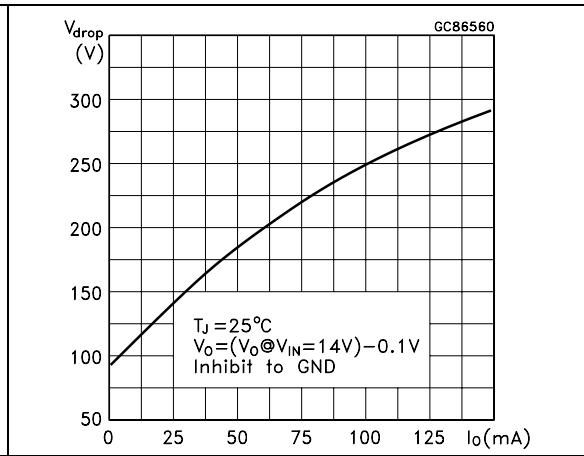

Figure 13. Output voltage vs. input voltage

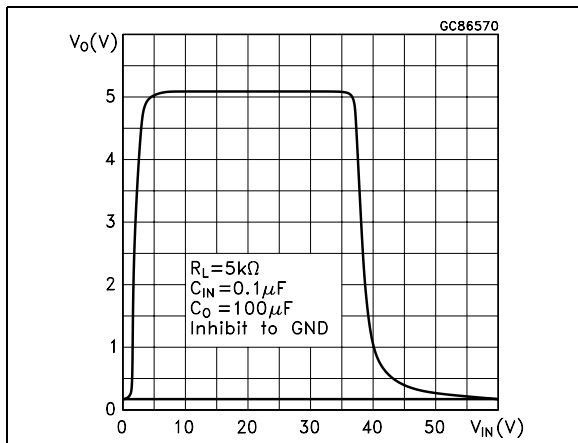

Figure 14. Short circuit current vs. drop voltage

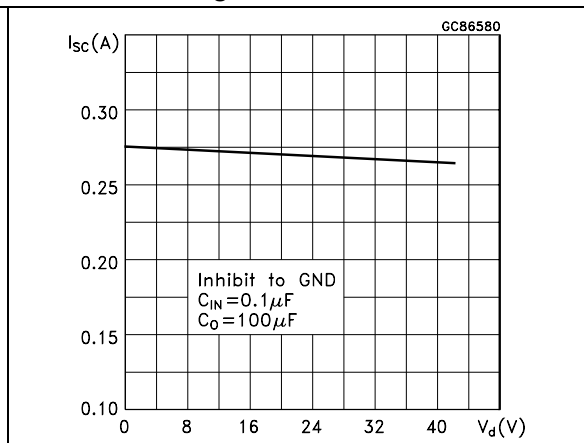

Figure 15. Quiescent current vs. temperature

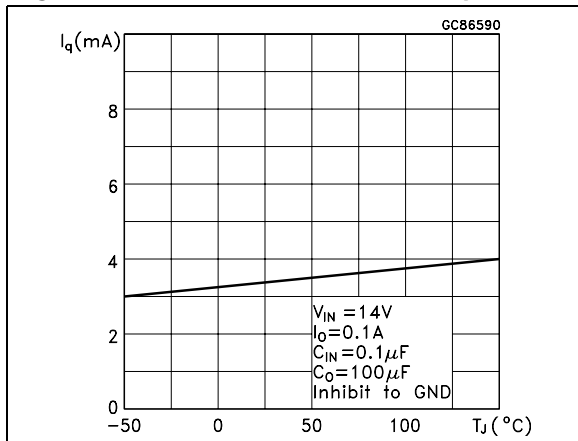

Figure 16. Quiescent current vs. input voltage

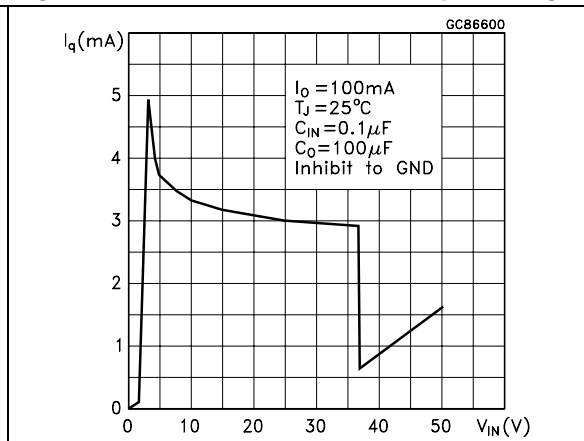

Figure 17. Quiescent current vs. output current

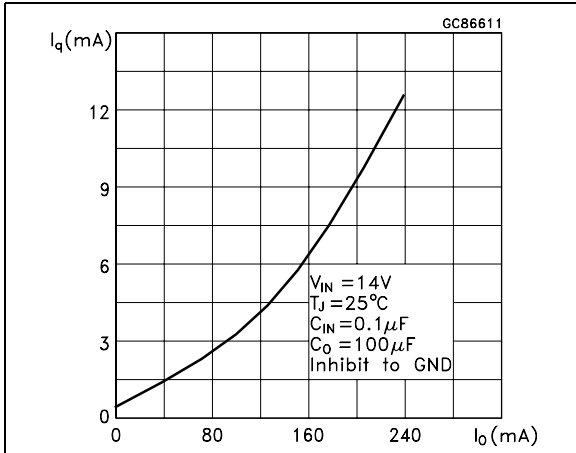

Figure 18. Supply voltage rejection vs. temperature

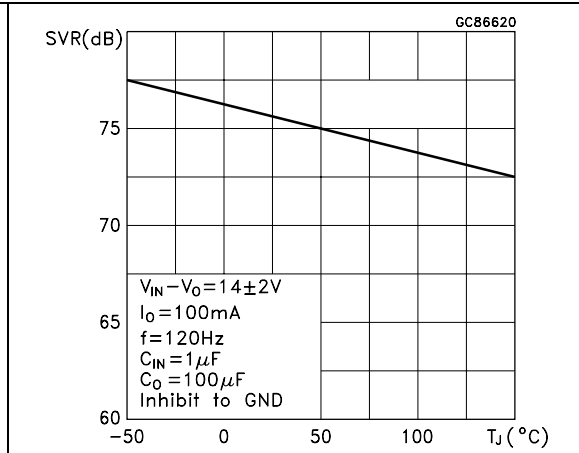

Figure 19. Supply voltage rejection vs. frequency

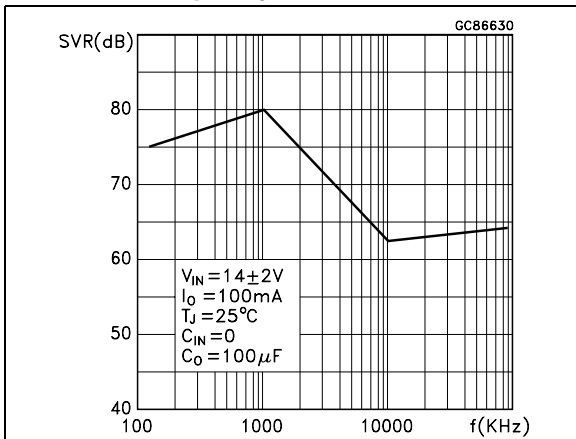

Figure 20. Supply voltage rejection vs. output current

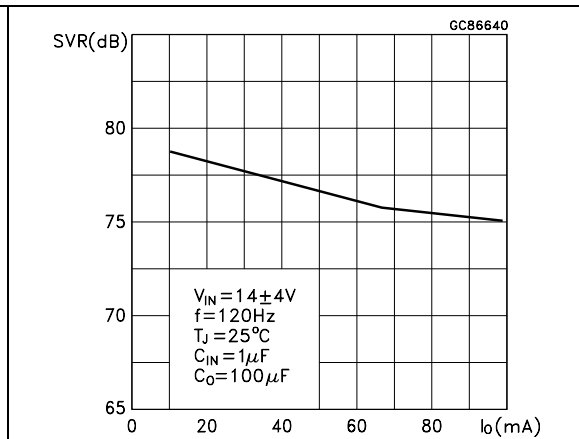

Figure 21. Stability vs. Co

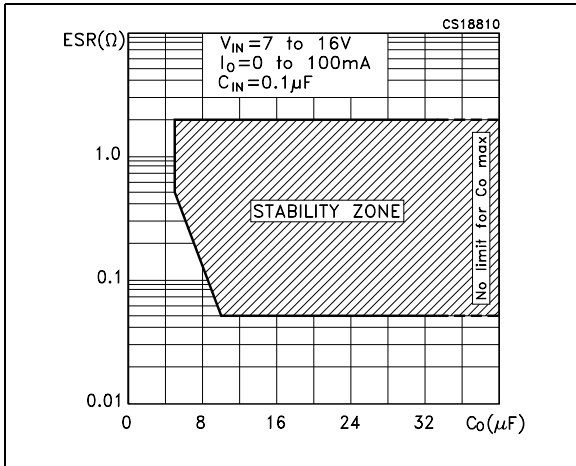

Figure 22. Line transient

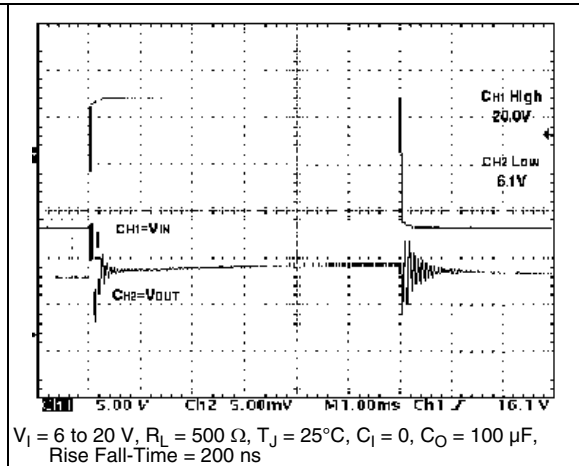
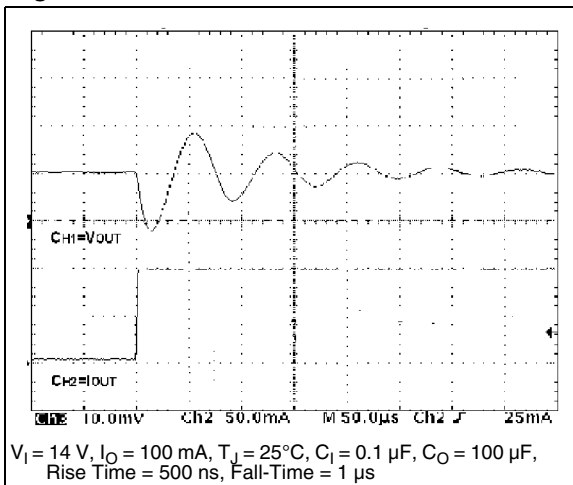

Figure 23. Line transient



7 Package mechanical data

In order to meet environmental requirements, ST offers these devices in different grades of ECOPACK[®] packages, depending on their level of environmental compliance. ECOPACK[®] specifications, grade definitions and product status are available at: www.st.com. ECOPACK[®] is an ST trademark.

TO-92 mechanical data

Dim.	mm.			mils.		
	Min.	Typ.	Max.	Min.	Typ.	Max.
A	4.32		4.95	170.1		194.9
b	0.36		0.51	14.2		20.1
D	4.45		4.95	175.2		194.9
E	3.30		3.94	129.9		155.1
e	2.41		2.67	94.9		105.1
e1	1.14		1.40	44.9		55.1
L	12.7		15.49	500.0		609.8
R	2.16		2.41	85.0		94.9
S1	0.92		1.52	36.2		59.8
W	0.41		0.56	16.1		22.0
α		5°			5°	

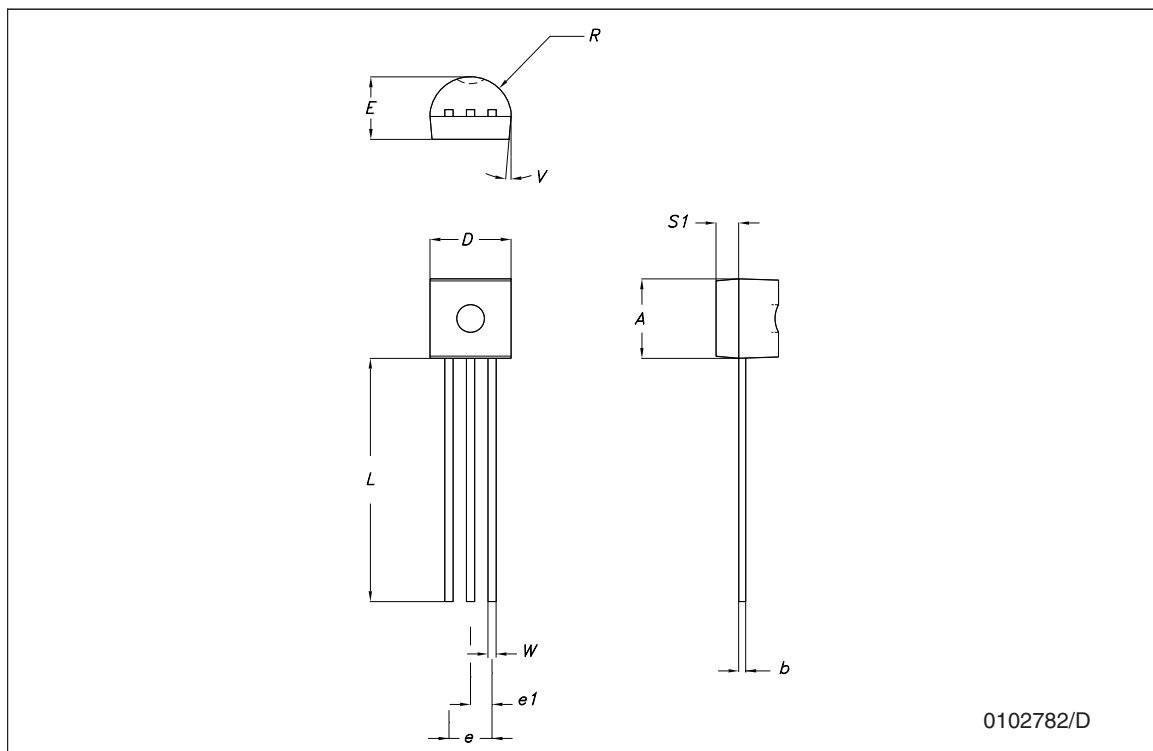

DPAK mechanical data

Dim.	mm.			inch.		
	Min.	Typ.	Max.	Min.	Typ.	Max.
A	2.2		2.4	0.086		0.094
A1	0.9		1.1	0.035		0.043
A2	0.03		0.23	0.001		0.009
B	0.64		0.9	0.025		0.035
b4	5.2		5.4	0.204		0.212
C	0.45		0.6	0.017		0.023
C2	0.48		0.6	0.019		0.023
D	6		6.2	0.236		0.244
D1		5.1			0.200	
E	6.4		6.6	0.252		0.260
E1		4.7			0.185	
e		2.28			0.090	
e1	4.4		4.6	0.173		0.181
H	9.35		10.1	0.368		0.397
L	1			0.039		
(L1)		2.8			0.110	
L2		0.8			0.031	
L4	0.6		1	0.023		0.039
R		0.2			0.008	
V2	0°		8°	0°		8°

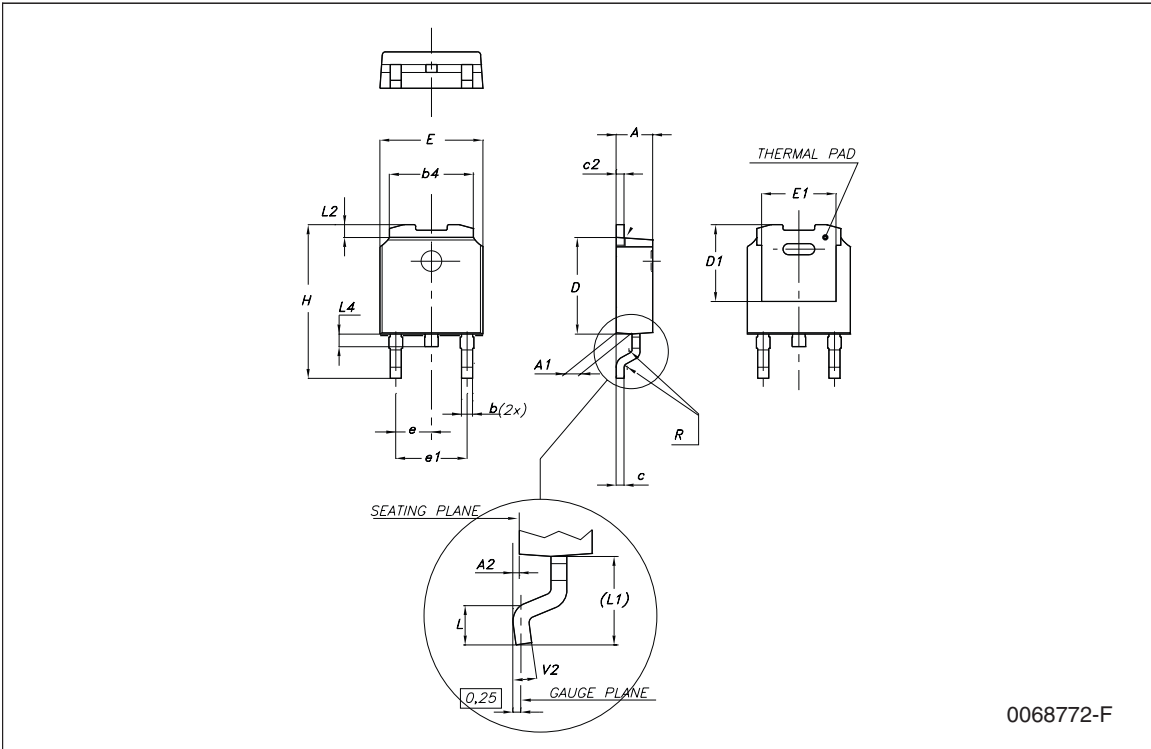

0068772-F

SO-8 mechanical data

Dim.	mm.			inch.		
	Min.	Typ.	Max.	Min.	Typ.	Max.
A	1.35		1.75	0.053		0.069
A1	0.10		0.25	0.04		0.010
A2	1.10		1.65	0.043		0.065
B	0.33		0.51	0.013		0.020
C	0.19		0.25	0.007		0.010
D	4.80		5.00	0.189		0.197
E	3.80		4.00	0.150		0.157
e		1.27			0.050	
H	5.80		6.20	0.228		0.244
h	0.25		0.50	0.010		0.020
L	0.40		1.27	0.016		0.050
k	8° (max.)					
ddd			0.1			0.04

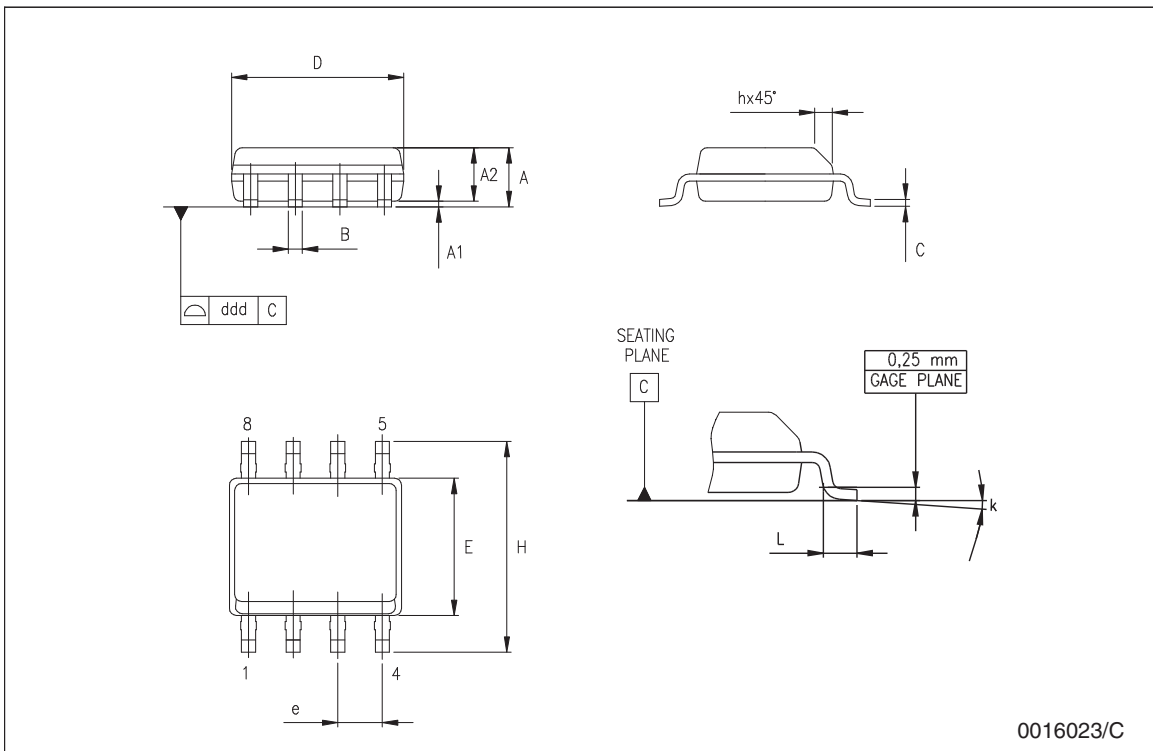

0016023/C



Tape & reel DPAK-PPAK mechanical data

Dim.	mm.			inch.		
	Min.	Typ.	Max.	Min.	Typ.	Max.
A			330			12.992
C	12.8	13.0	13.2	0.504	0.512	0.519
D	20.2			0.795		
N	60			2.362		
T			22.4			0.882
Ao	6.80	6.90	7.00	0.268	0.272	0.276
Bo	10.40	10.50	10.60	0.409	0.413	0.417
Ko	2.55	2.65	2.75	0.100	0.104	0.105
Po	3.9	4.0	4.1	0.153	0.157	0.161
P	7.9	8.0	8.1	0.311	0.315	0.319

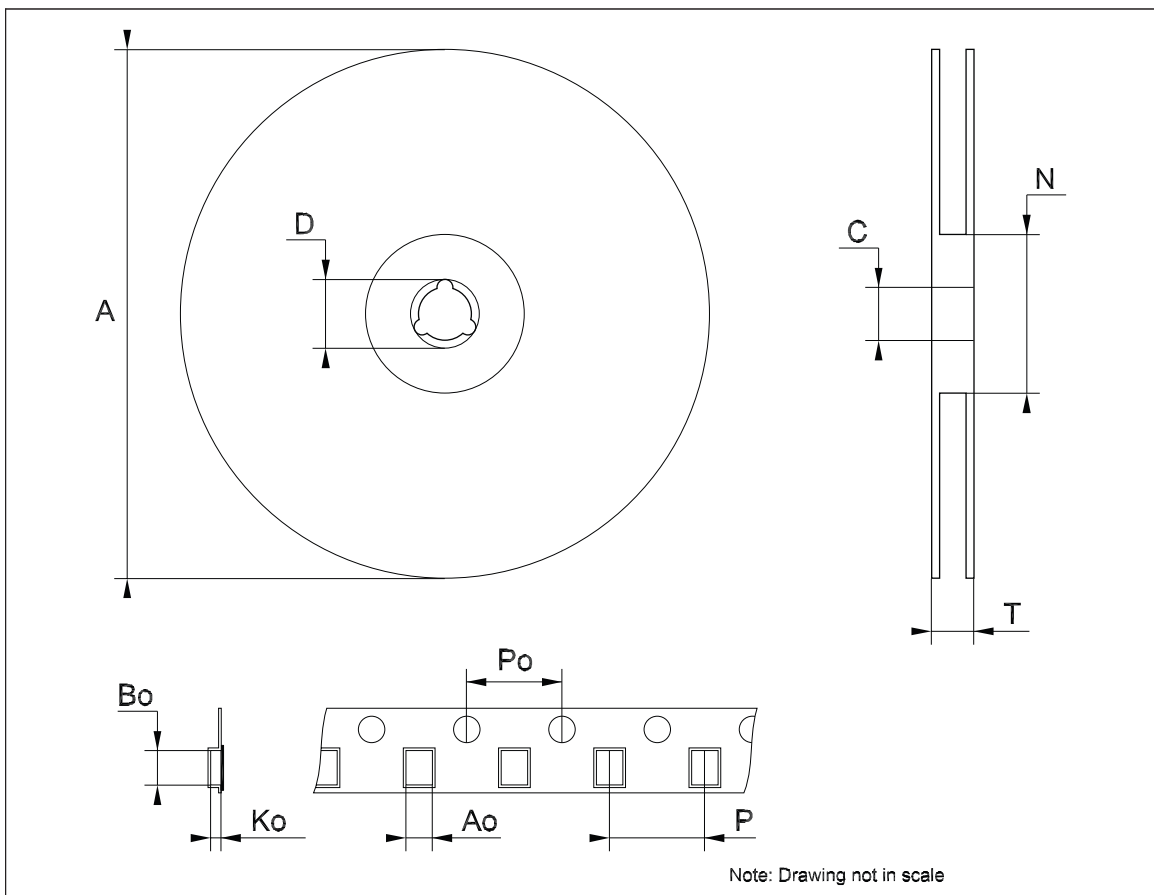

Tape & reel SO-8 mechanical data

Dim.	mm.			inch.		
	Min.	Typ.	Max.	Min.	Typ.	Max.
A			330			12.992
C	12.8		13.2	0.504		0.519
D	20.2			0.795		
N	60			2.362		
T			22.4			0.882
Ao	8.1		8.5	0.319		0.335
Bo	5.5		5.9	0.216		0.232
Ko	2.1		2.3	0.082		0.090
Po	3.9		4.1	0.153		0.161
P	7.9		8.1	0.311		0.319

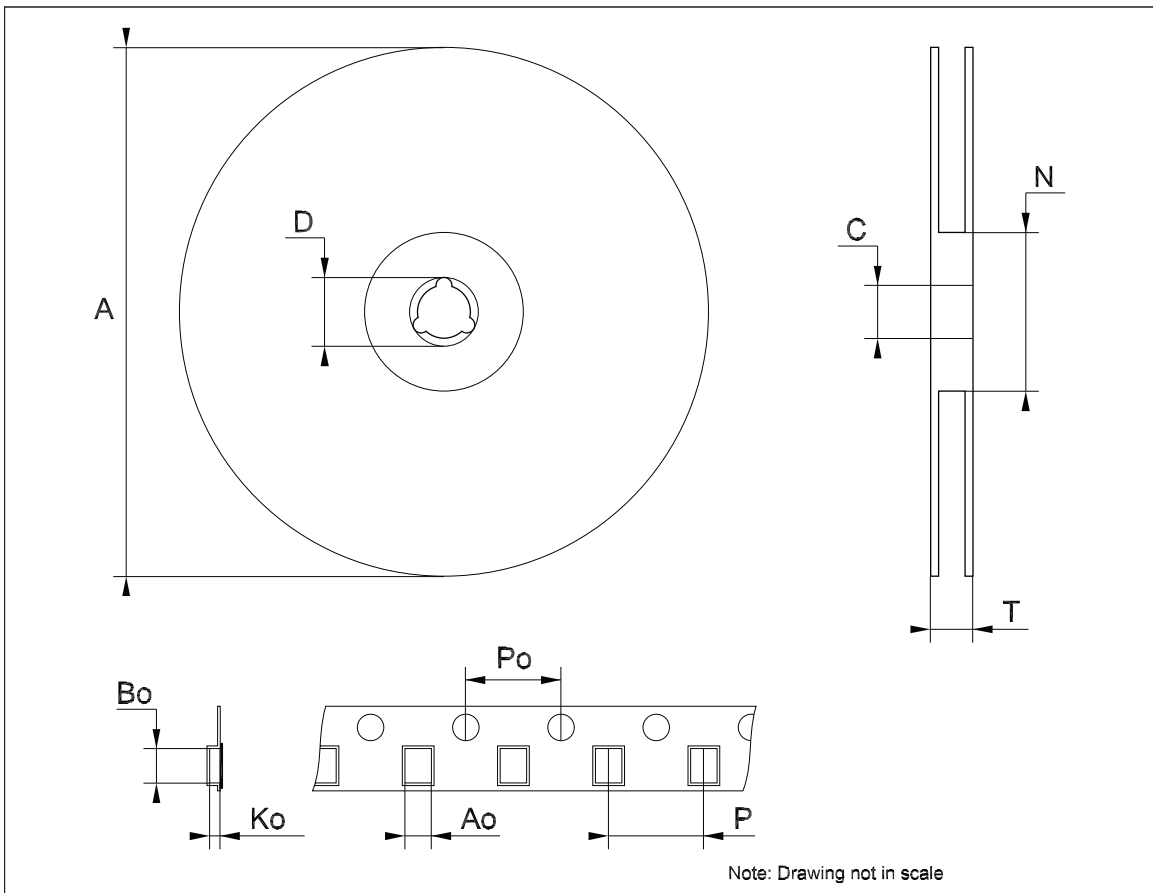

8 Revision history

Table 7. Document revision history

Date	Revision	Changes
21-Jun-2004	12	Document updated.
16-Jun-2006	13	Order codes updated.
27-Jul-2007	14	Added Table 1 in cover page.
21-Aug-2007	15	Added root part number - (see Table 1).
22-Nov-2007	16	Modified: Table 1 .
11-Feb-2008	17	Modified: Table 1 on page 1 .
10-Jul-2008	18	Removed package TO-220, modified Table 1 on page 1 .
26-May-2010	19	Modified: V_1 values Table 4 on page 7 , Table 5 on page 8 and Table 6 on page 9 .

Please Read Carefully:

Information in this document is provided solely in connection with ST products. STMicroelectronics NV and its subsidiaries ("ST") reserve the right to make changes, corrections, modifications or improvements, to this document, and the products and services described herein at any time, without notice.

All ST products are sold pursuant to ST's terms and conditions of sale.

Purchasers are solely responsible for the choice, selection and use of the ST products and services described herein, and ST assumes no liability whatsoever relating to the choice, selection or use of the ST products and services described herein.

No license, express or implied, by estoppel or otherwise, to any intellectual property rights is granted under this document. If any part of this document refers to any third party products or services it shall not be deemed a license grant by ST for the use of such third party products or services, or any intellectual property contained therein or considered as a warranty covering the use in any manner whatsoever of such third party products or services or any intellectual property contained therein.

UNLESS OTHERWISE SET FORTH IN ST'S TERMS AND CONDITIONS OF SALE ST DISCLAIMS ANY EXPRESS OR IMPLIED WARRANTY WITH RESPECT TO THE USE AND/OR SALE OF ST PRODUCTS INCLUDING WITHOUT LIMITATION IMPLIED WARRANTIES OF MERCHANTABILITY, FITNESS FOR A PARTICULAR PURPOSE (AND THEIR EQUIVALENTS UNDER THE LAWS OF ANY JURISDICTION), OR INFRINGEMENT OF ANY PATENT, COPYRIGHT OR OTHER INTELLECTUAL PROPERTY RIGHT.

UNLESS EXPRESSLY APPROVED IN WRITING BY AN AUTHORIZED ST REPRESENTATIVE, ST PRODUCTS ARE NOT RECOMMENDED, AUTHORIZED OR WARRANTED FOR USE IN MILITARY, AIR CRAFT, SPACE, LIFE SAVING, OR LIFE SUSTAINING APPLICATIONS, NOR IN PRODUCTS OR SYSTEMS WHERE FAILURE OR MALFUNCTION MAY RESULT IN PERSONAL INJURY, DEATH, OR SEVERE PROPERTY OR ENVIRONMENTAL DAMAGE. ST PRODUCTS WHICH ARE NOT SPECIFIED AS "AUTOMOTIVE GRADE" MAY ONLY BE USED IN AUTOMOTIVE APPLICATIONS AT USER'S OWN RISK.

Resale of ST products with provisions different from the statements and/or technical features set forth in this document shall immediately void any warranty granted by ST for the ST product or service described herein and shall not create or extend in any manner whatsoever, any liability of ST.

ST and the ST logo are trademarks or registered trademarks of ST in various countries.

Information in this document supersedes and replaces all information previously supplied.

The ST logo is a registered trademark of STMicroelectronics. All other names are the property of their respective owners.

© 2010 STMicroelectronics - All rights reserved

STMicroelectronics group of companies

Australia - Belgium - Brazil - Canada - China - Czech Republic - Finland - France - Germany - Hong Kong - India - Israel - Italy - Japan - Malaysia - Malta - Morocco - Philippines - Singapore - Spain - Sweden - Switzerland - United Kingdom - United States of America

www.st.com

