

PQ1Uxx1M2ZPH Series

Low Output Current, Compact Surface Mount Type
Low Power-Loss Voltage Regulators

■ Features

- 1.Compact surface mount package (2.9×1.6×1.1mm)
- 2.Low power-loss
(Dropout voltage: TYP. 0.11 V at I_o=60mA)
- 3.High ripple rejection (TYP. 70dB)
- 4.Built-in ON/OFF control function
(Dissipation current at OFF-state: MAX. 1μA)
- 5.Built-in overcurrent, overheat protection functions
*It is available for every 0.1V of output voltage (1.3V to 5.0V)
- 6.RoHS directive compliant

■ Applications

- 1.Cellular phones
- 2.Cordless phones
- 3.Personal information tools (PDA)
- 4.Cameras/Camcoders
- 5.PCMCIA cards for notebook PCs

■ Model Line-up

| Output Voltage (TYP.) | Model No. | Output Voltage (TYP.) | Model No. |
|-----------------------|--------------|-----------------------|--------------|
| 1.8V | PQ1U181M2ZPH | 3.5V | PQ1U351M2ZPH |
| 2.5V | PQ1U251M2ZPH | 5.0V | PQ1U501M2ZPH |
| 2.8V | PQ1U281M2ZPH | | |
| 3.0V | PQ1U301M2ZPH | | |
| 3.3V | PQ1U331M2ZPH | | |

■ Absolute Maximum Ratings

(Ta=25°C)

| Parameter | Symbol | Rating | Unit |
|------------------------------------|------------------|-------------|------|
| *1 Input voltage | V _{IN} | 16 | V |
| *1 ON/OFF control terminal voltage | V _C | 16 | V |
| Output current | I _o | 300 | mA |
| *2 Power dissipation | P _D | 350 | mW |
| *3 Junction temperature | T _j | 150 | °C |
| Operating temperature | T _{opr} | -30 to +85 | °C |
| Storage temperature | T _{stg} | -55 to +150 | °C |
| Soldering temperature | T _{sol} | 270(10s) | °C |

*1 All are open except GND and applicable terminals.
*2 At mounted on PCB
*3 Overheat protection may operate at T_j=125°C to 150°C

■ Outline Dimensions

(Unit : mm)

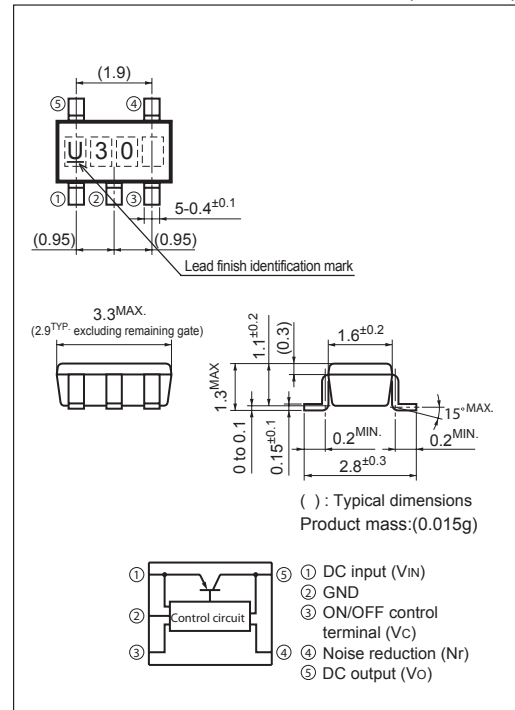

Lead finish:Lead-free solder plating
(Composition: Sn2Cu)

Notice The content of data sheet is subject to change without prior notice.

In the absence of confirmation by device specification sheets, SHARP takes no responsibility for any defects that may occur in equipment using any SHARP devices shown in catalogs, data books, etc. Contact SHARP in order to obtain the latest device specification sheets before using any SHARP device.

Electrical Characteristics

(Unless otherwise specified, $V_{IN}=V_O(TYP) + 1.0V$, $I_O=30mA$, $V_C=1.8V$, $T_a=25^\circ C$)

| Parameter | Symbol | Conditions | MIN. | TYP. | MAX. | Unit |
|---|---------------|---|--------------------------------|------|------|----------------|
| Output voltage | V_O | - | Refer to the following table.1 | | | V |
| *4 Output peak current | I_{OP} | - | 180 | 300 | - | mA |
| Recommended output current | - | - | - | - | 150 | mA |
| Load regulation | RegL1 | $I_O=5$ to 60mA | - | 10 | 50 | mV |
| | RegL2 | $I_O=5$ to 100mA | - | 20 | 100 | mV |
| | RegL3 | $I_O=5$ to 150mA | - | 30 | 160 | mV |
| Line regulation | RegL | $V_{IN}=V_O(TYP)+1V$ to $V_O(TYP)+6V$ | - | 3.0 | 20 | mV |
| Temperature coefficient of output voltage | $T_C V_O$ | $I_O=10mA$, $T_j=-25$ to $+75^\circ C$ | - | 0.05 | - | mV/ $^\circ C$ |
| Ripple rejection | RR | Refer to Fig.2 | - | 70 | - | dB |
| Output noise voltage | $V_{NO}(rms)$ | $10Hz < f < 100kHz$, $C_n=0.1\mu F$, $I_O=30mA$ | Refer to the following table.2 | | | μV |
| *8 Dropout voltage | V_{I-O1} | $I_O=60mA$ *5 | - | 0.11 | 0.26 | V |
| | V_{I-O2} | $I_O=150mA$ *5 | - | 0.20 | 0.4 | |
| *6 ON-state voltage for control | $V_{C(ON)}$ | - | 1.8 | - | - | V |
| ON-state current for control | $I_{C(ON)}$ | $V_C=1.8V$ | - | 5 | 30 | μA |
| OFF-state voltage for control | $V_{C(OFF)}$ | - | - | - | 0.4 | V |
| Quiescent current | I_Q | $I_O=0mA$ | - | 130 | 200 | μA |
| Output OFF-state dissipation current | I_{QS} | $V_C=0.2V$ | - | - | 1 | μA |

- *4 Output current shall be the value when output voltage lowers 0.3V from the voltage at $I_O=30mA$.
- *5 Input voltage when output voltage falls 0.1V from that at $V_{IN}=V_O(TYP)+1.0V$.
- *6 In case that the control terminal (③ pin) is open, output voltage should be OFF state.
- *7 In case of PQ1U181M2ZPH, V_{IN} minimum=2.3V.
- *8 Excluding PQ1U181M2ZPH

Table.1 Output Voltage

$(V_{IN}=V_O(TYP)+1.0V, I_O=30mA, V_C=1.8V, T_a=25^\circ C)$

| Model No. | Symbol | MIN. | TYP. | MAX. | Unit |
|--------------|--------|-------|------|-------|------|
| PQ1U181M2ZPH | V_O | 1.740 | 1.8 | 1.860 | V |
| PQ1U251M2ZPH | | 2.440 | 2.5 | 2.560 | |
| PQ1U281M2ZPH | | 2.740 | 2.8 | 2.860 | |
| PQ1U301M2ZPH | | 2.940 | 3.0 | 3.060 | |
| PQ1U331M2ZPH | | 3.234 | 3.3 | 3.366 | |
| PQ1U351M2ZPH | | 3.430 | 3.5 | 3.570 | |
| PQ1U501M2ZPH | | 4.900 | 5.0 | 5.100 | |

Table.2 Output Noise Voltage

$(V_{IN}=V_O(TYP)+1.0V, I_O=30mA, V_C=1.8V, C_n=0.1\mu F, 10Hz < f < 100kHz, T_a=25^\circ C)$

| Model No. | Symbol | MIN. | TYP. | MAX. | Unit |
|--------------|---------------|------|------|------|---------|
| PQ1U181M2ZPH | $V_{NO}(rms)$ | - | 15 | - | μV |
| PQ1U251M2ZPH | | - | 25 | - | |
| PQ1U281M2ZPH | | - | 25 | - | |
| PQ1U301M2ZPH | | - | 30 | - | |
| PQ1U331M2ZPH | | - | 30 | - | |
| PQ1U351M2ZPH | | - | 35 | - | |
| PQ1U501M2ZPH | | - | 50 | - | |

Fig.1 Test Circuit

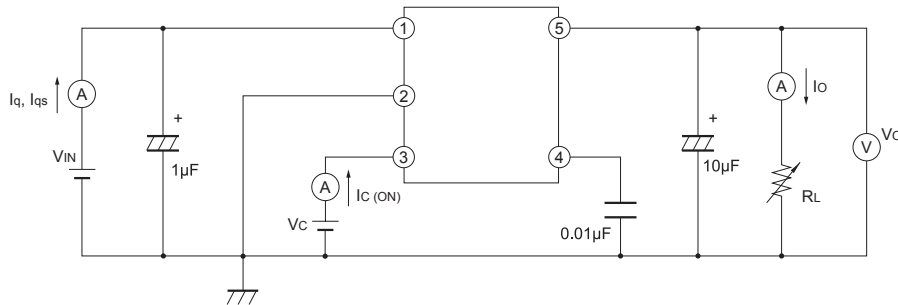

Fig.2 Test Circuit for Ripple Rejection

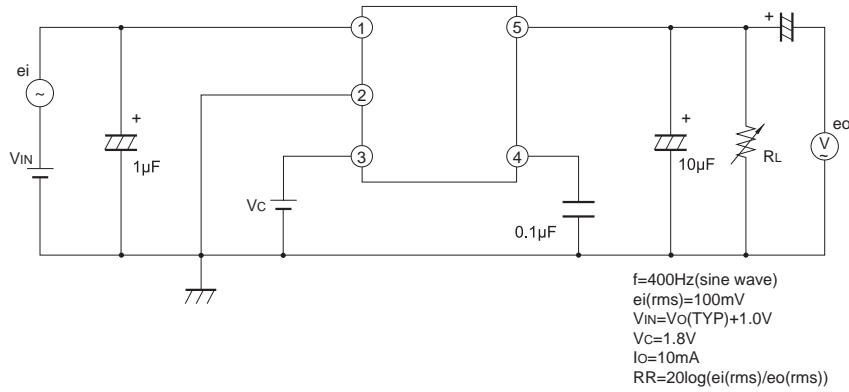
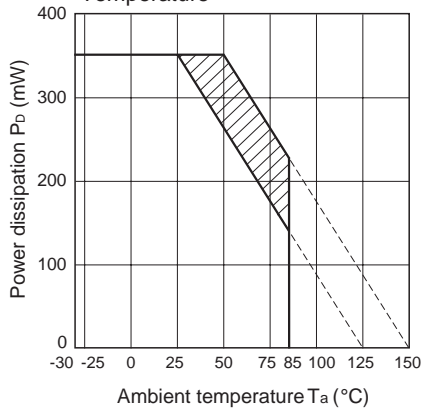

Fig.3 Power Dissipation vs. Ambient Temperature



Note) Oblique line portion:Overheat protection may operate in this area.

Fig.4 Overcurrent Protection Characteristics (Typical Value)

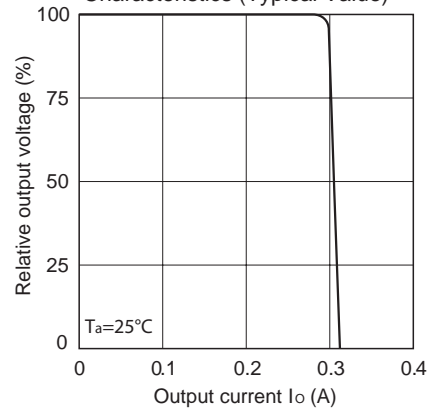

Fig.5 Output Voltage Fluctuation vs. Junction Temperature (PQ1U281M2ZPH)(Typical Value)

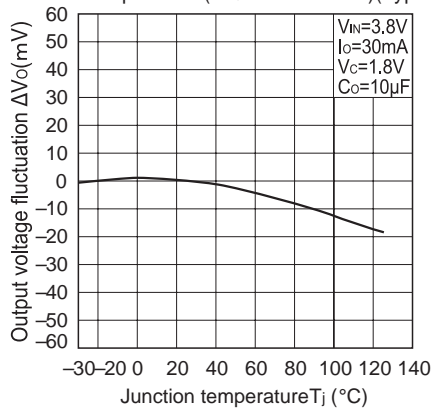

Fig.6 Output Voltage vs. Input Voltage (PQ1U281M2ZPH)(Typical Value)

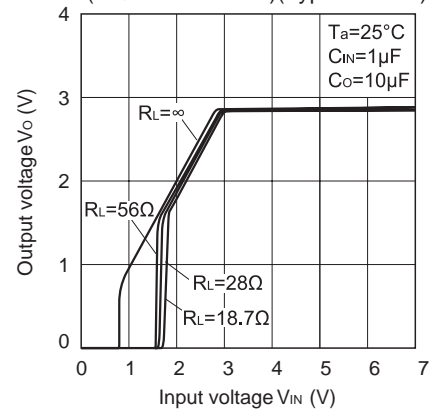

Fig.7 Circuit Operating Current vs. Input Voltage (PQ1U281M2ZPH)(Typical Value)

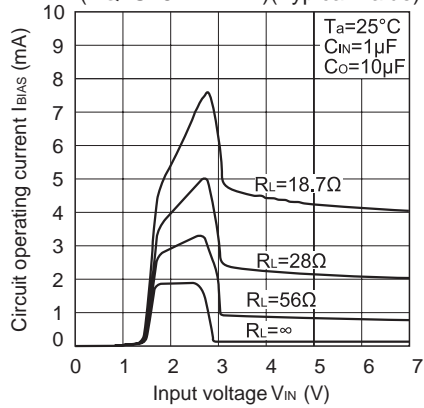

Fig.8 Dropout Voltage vs. Junction Temperature (PQ1U281M2ZPH)(Typical Value)

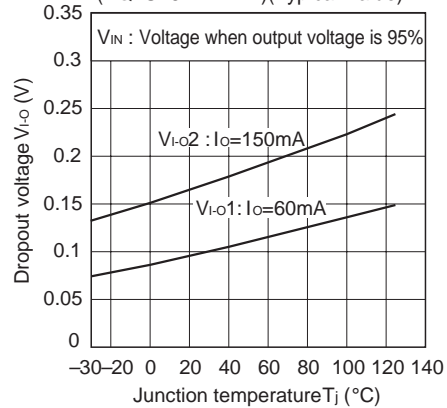

Fig.9 Quiescent Current vs. Junction Temperature (Typical Value)

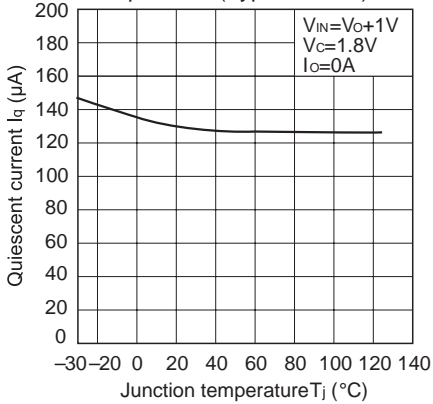

Fig.10 Ripple Rejection vs. Input Ripple Frequency (PQ1U281M2ZPH)(Typical Value)

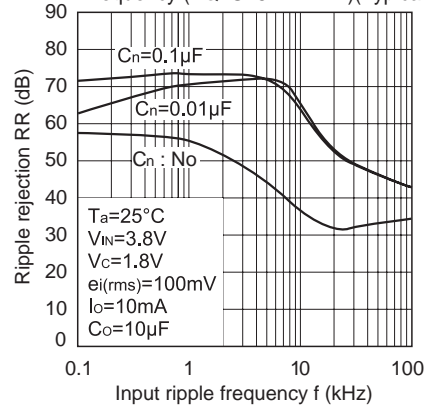

Fig.11 Dropout Voltage vs. Output Current (Typical Value)

