

PQ1Xxx1M2ZPH Series

Low Output Current, Compact Surface Mount Type
Low Power-Loss Voltage Regulators

■ Features

- 1.Compact surface mount package (2.9×1.6×1.1mm)
- 2.Low power-loss
(Dropout voltage: TYP. 0.11 V/MAX. 0.26V at $I_o=60\text{mA}$)
Also compatible ceramic capacitors because of suppressing oscillation level
- 3.High ripple rejection (TYP. 70dB)
- 4.Built-in ON/OFF control function
(Dissipation current at OFF-state: MAX. 1 μA)
- 5.Built-in overcurrent and overheat protection functions
*It is available for every 0.1V of output voltage (1.3V to 5.0V)
- 6.RoHS directive compliant

■ Applications

- 1.Cellular phones
- 2.Cordless phones
- 3.Personal information tools (PDA)
- 4.Cameras/Camcoders
- 5.PCMCIA cards for notebook PCs

■ Model Line-up

Output Voltage (TYP.)	Model No.	Output Voltage (TYP.)	Model No.
1.5V	PQ1X151M2ZPH	3.0V	PQ1X301M2ZPH
1.8V	PQ1X181M2ZPH	3.3V	PQ1X331M2ZPH
2.5V	PQ1X251M2ZPH	3.5V	PQ1X351M2ZPH
2.6V	PQ1X261M2ZPH	3.7V	PQ1X371M2ZPH
2.7V	PQ1X271M2ZPH	4.0V	PQ1X401M2ZPH
2.8V	PQ1X281M2ZPH	4.5V	PQ1X451M2ZPH
2.9V	PQ1X291M2ZPH	5.0V	PQ1X501M2ZPH

■ Absolute Maximum Ratings

($T_a=25^\circ\text{C}$)

Parameter	Symbol	Rating	Unit
*1 Input voltage	V_{IN}	9	V
*1 ON/OFF control terminal voltage	V_C	9	V
Output current	I_o	300	mA
*2 Power dissipation	P_D	350	mW
*3 Junction temperature	T_j	150	$^\circ\text{C}$
Operating temperature	T_{opr}	-30 to +85	$^\circ\text{C}$
Storage temperature	T_{stg}	-55 to +150	$^\circ\text{C}$
Soldering temperature	T_{sol}	270(10s)	$^\circ\text{C}$

*1 All are open except GND and applicable terminals.
*2 At mounted on PCB
*3 Overheat protection may operate at $T_j:125^\circ\text{C}$ to 150°C

■ Outline Dimensions

(Unit : mm)

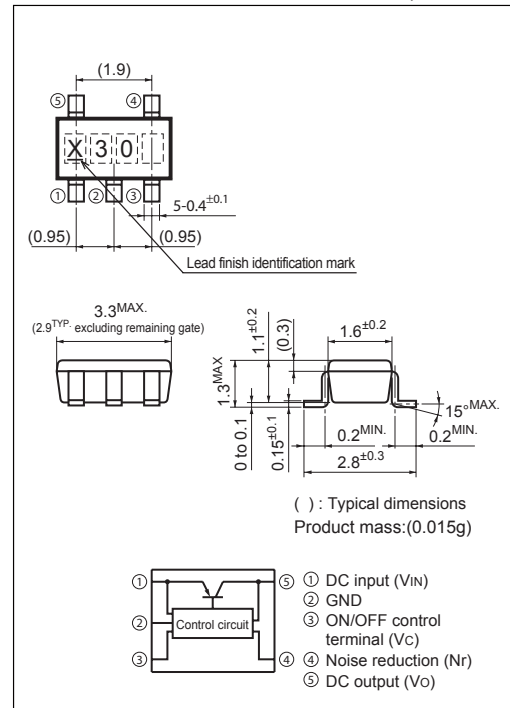

Lead finish:Lead-free solder plating
(Composition: Sn2Cu)

Notice The content of data sheet is subject to change without prior notice.

In the absence of confirmation by device specification sheets, SHARP takes no responsibility for any defects that may occur in equipment using any SHARP devices shown in catalogs, data books, etc. Contact SHARP in order to obtain the latest device specification sheets before using any SHARP device.

Electrical Characteristics

(Unless otherwise specified, $V_{IN}=V_O(TYP) + 1.0V$, $I_o=30mA$, $V_c=1.8V$, $T_a=25^\circ C$)

Parameter	Symbol	Conditions	MIN.	TYP.	MAX.	Unit
Output voltage	V_O	-	Refer to the following table.1			V
*4 Input voltage	V_{IN}	-	2.3	-	9	V
*5 Output peak current	I_{op}	-	180	300	-	mA
Recommended output current	-	-	-	-	150	mA
Load regulation	RegL1	$I_o=5$ to 60mA	-	10	50	mV
	RegL2	$I_o=5$ to 100mA	-	20	100	mV
	RegL3	$I_o=5$ to 150mA	-	40	160	mV
Line regulation	RegL	$V_{IN}=V_O(TYP)+1V$ to $V_O(TYP)+6V$ (MAX.9.0V)	-	3.0	20	mV
Temperature coefficient of output voltage	T_cV_O	$I_o=10mA$, $T_j=-25$ to $+75^\circ C$	-	0.05	-	mV/ $^\circ C$
Ripple rejection	RR	Refer to Fig.2	-	70	-	dB
Output noise voltage	$V_{no}(rms)$	$10Hz < f < 100kHz$, $C_n F=0.1\mu F$, $I_o=30mA$	Refer to the following table.2			μV
*6 Dropout voltage	V_{I-O1}	$I_o=60mA$ *7	-	0.11	0.26	V
	V_{I-O2}	$I_o=150mA$ *7	-	0.20	0.4	
*8 ON-state voltage for control	$V_{C(ON)}$	-	1.8	-	-	V
ON-state current for control	$I_{C(ON)}$	$V_c=1.8V$	-	5	30	μA
OFF-state voltage for control	$V_{C(OFF)}$	-	-	-	0.4	V
Quiescent current	I_q	$I_o=0mA$	-	150	200	μA
Output OFF-state dissipation current	I_{qs}	$V_c=0.2V$	-	-	1	μA

*4 Applied to PQ1X151M2ZPH and PQ1X181M2ZPH

*5 Output current shall be the value when output voltage lowers 0.3V from the voltage at $I_o=30mA$.

*6 Excluding PQ1X151M2ZPH and PQ1X181M2ZPH

*7 Input voltage when output voltage falls 0.1V from that at $V_{IN}=V_O(TYP)+1.0V$.

*8 In case that the control terminal (③ pin) is open, output voltage should be OFF state.

Table.1 Output Voltage

($V_{IN}=V_O(TYP)+1.0V$, $I_o=30mA$, $V_c=1.8V$, $T_a=25^\circ C$)

Model No.	Symbol	MIN.	TYP.	MAX.	Unit
PQ1X151M2ZPH	V_O	1.440	1.5	1.560	V
PQ1X181M2ZPH		1.740	1.8	1.860	
PQ1X251M2ZPH		2.440	2.5	2.560	
PQ1X261M2ZPH		2.540	2.6	2.660	
PQ1X271M2ZPH		2.640	2.7	2.760	
PQ1X281M2ZPH		2.740	2.8	2.860	
PQ1X291M2ZPH		2.840	2.9	2.960	
PQ1X301M2ZPH		2.940	3.0	3.060	
PQ1X331M2ZPH		3.234	3.3	3.366	
PQ1X351M2ZPH		3.430	3.5	3.570	
PQ1X371M2ZPH		3.626	3.7	3.774	
PQ1X401M2ZPH		3.920	4.0	4.080	
PQ1X451M2ZPH		4.410	4.5	4.590	
PQ1X501M2ZPH		4.900	5.0	5.100	

Table.2 Output Noise Voltage

($V_{IN}=V_O(TYP)+1.0V$, $I_o=30mA$, $V_c=1.8V$, $C_n=0.1\mu F$, $10Hz < f < 100kHz$, $T_a=25^\circ C$)

Model No.	Symbol	MIN.	TYP.	MAX.	Unit
PQ1X151M2ZPH	$V_{no}(rms)$	-	15	-	μV
PQ1X181M2ZPH		-	15	-	
PQ1X251M2ZPH		-	25	-	
PQ1X261M2ZPH		-	25	-	
PQ1X271M2ZPH		-	25	-	
PQ1X281M2ZPH		-	25	-	
PQ1X291M2ZPH		-	25	-	
PQ1X301M2ZPH		-	30	-	
PQ1X331M2ZPH		-	30	-	
PQ1X351M2ZPH		-	35	-	
PQ1X371M2ZPH		-	35	-	
PQ1X401M2ZPH		-	40	-	
PQ1X451M2ZPH		-	45	-	
PQ1X501M2ZPH		-	50	-	

Fig.1 Test Circuit

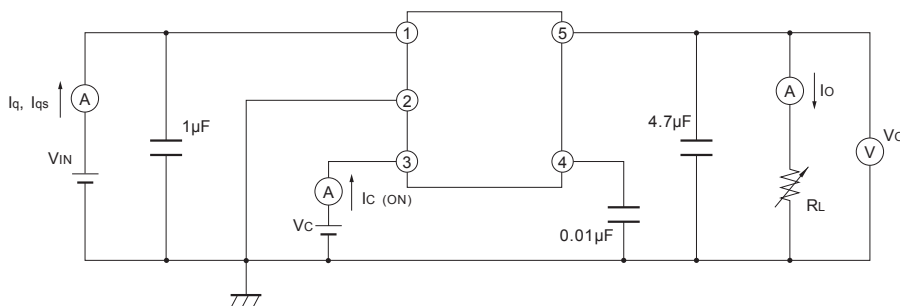

Fig.2 Test Circuit for Ripple Rejection

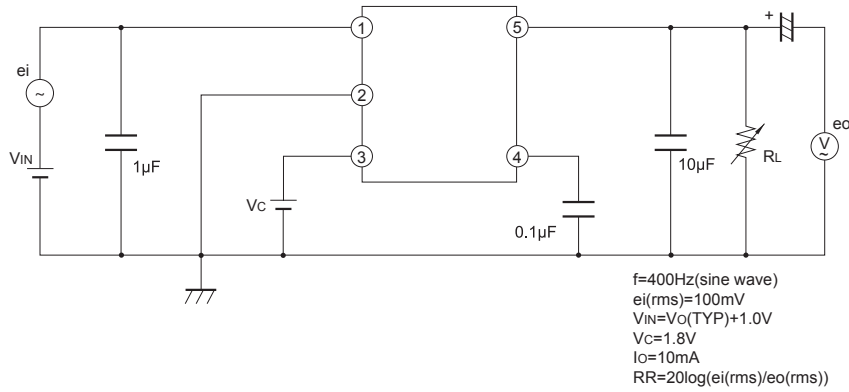
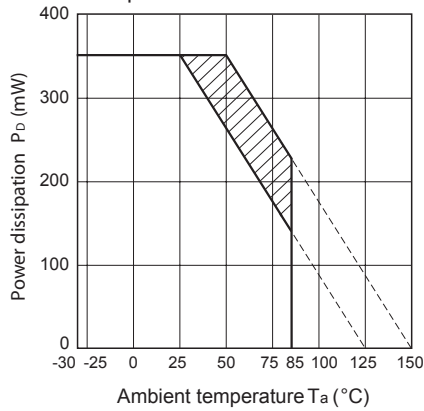

Fig.3 Power Dissipation vs. Ambient Temperature



Note) Oblique line portion:Overheat protection may operate in this area.

Fig.4 Overcurrent Protection Characteristics (Typical Value)

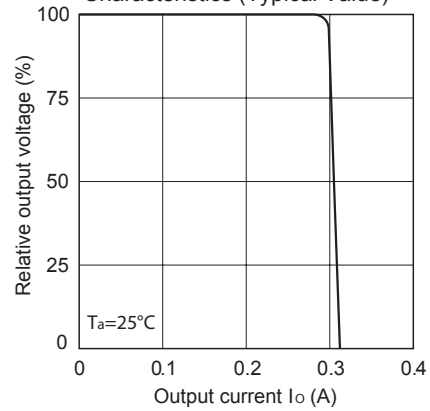

Fig.5 Output Voltage Fluctuation vs. Junction Temperature (PQ1X301M2ZPH)(Typical Value)

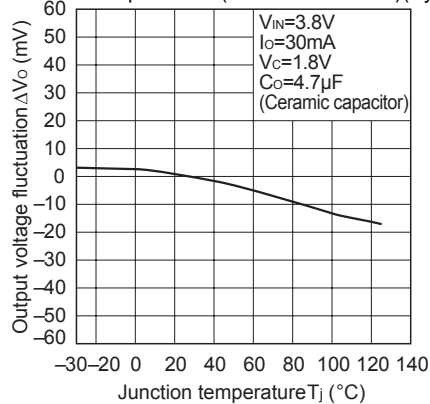

Fig.6 Output Voltage vs. Input Voltage (PQ1X301M2ZPH)(Typical Value)

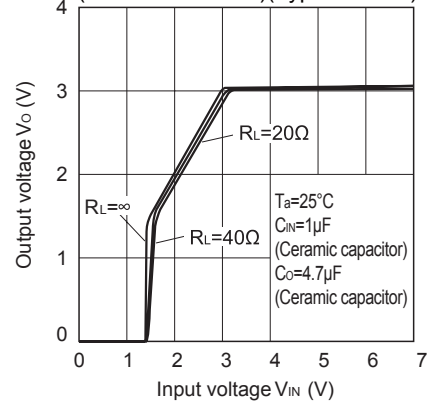

Fig.7 Circuit Operating Current vs. Input Voltage (PQ1X301M2ZPH)(Typical Value)

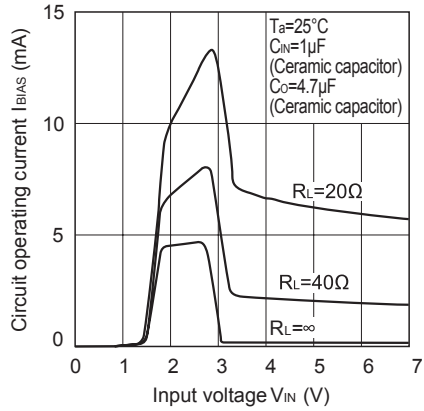

Fig.8 Dropout Voltage vs. Junction Temperature (PQ1X301M2ZPH)(Typical Value)

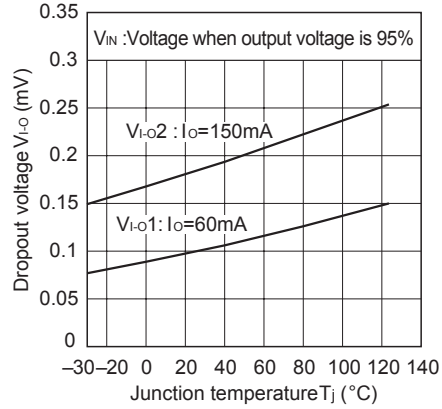

Fig.9 Quiescent Current vs. Junction Temperature (Typical Value)

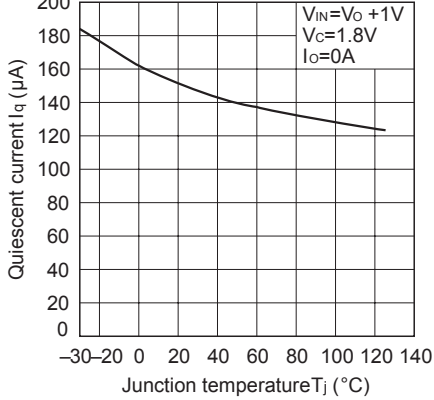

Fig.10 Ripple Rejection vs. Input Ripple Frequency (PQ1X281M2ZPH)(Typical Value)

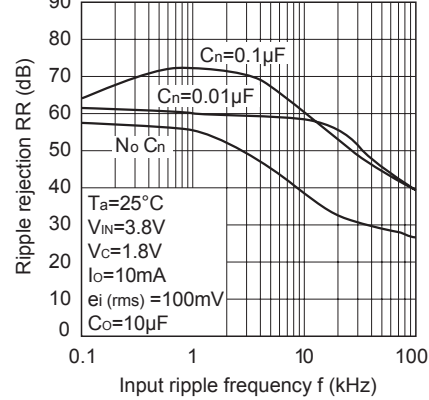

Fig.11 Dropout Voltage vs. Output Current (Typical Value)

