

# Micropower Regulator with Comparator and Shutdown

## FEATURES

- 20 $\mu$ A Supply Current
- 125mA Output Current
- 2.5V Reference
- Reference Output Sources 4mA and Sinks 4mA
- Open Collector Comparator Sinks 10mA
- Logic Shutdown
- 0.2V Dropout Voltage
- Thermal Limiting
- 8-Lead SO Package

## APPLICATIONS

- Battery Systems
- Battery Backup System
- Portable Terminals
- Portable Instruments
- Memory Keep Alive

## DESCRIPTION

The LT<sup>®</sup>1120A is a combination micropower positive regulator and free collector comparator on a single monolithic chip. With only 20 $\mu$ A supply current, the LT1120A can supply over 125mA of output current. Input voltage range is from 4.5V to 36V and dropout voltage is 0.6V at 125mA. Dropout voltage decreases with lower load currents. Also included on the chip is a class B output 2.5V reference that can either source or sink current. This allows it to be used as a supply splitter or auxiliary output. A shutdown pin allows logic shutdown of the output.

The comparator can be used for system or battery monitoring. For example, the comparator can be used to warn of low system voltage. Frequency compensation of the comparator for amplifier applications can be obtained by adding external output capacitance.

LT, LTC and LT are registered trademarks of Linear Technology Corporation.

## TYPICAL APPLICATION

**5V Regulator**

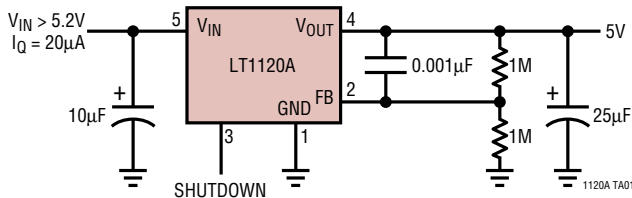

**Dropout Voltage and Supply Current**

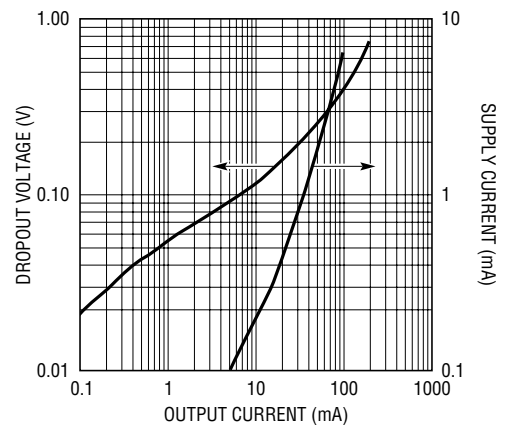

# LT1120A

## ABSOLUTE MAXIMUM RATINGS

(Note 1)

Input Voltage .....	36V
NPN Collector Voltage .....	36V
Output Short-Circuit Duration .....	Indefinite
Power Dissipation .....	Internally Limited
Operating Temperature Range	
LT1120AC .....	0°C to 100°C
LT1120AI .....	-40°C to 100°C
Storage Temperature Range .....	-65°C to 150°C

## PACKAGE/ORDER INFORMATION

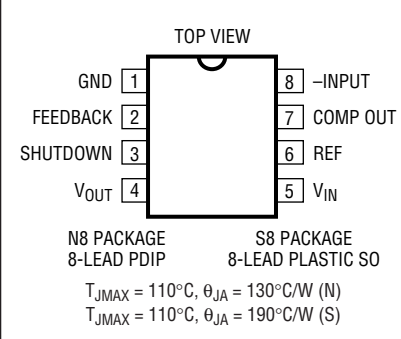
	ORDER PART NUMBER
	LT1120ACN8 LT1120ACS8 LT1120AIS8
	S8 PART MARKING
	1120A 1120AI

Consult LTC Marketing for parts specified with wider operating temperature ranges.

## ELECTRICAL CHARACTERISTICS $T_J = 25^\circ\text{C}$

PARAMETER	CONDITIONS	MIN	TYP	MAX	UNITS
<b>Reference</b>					
Reference Voltage	$4.5\text{V} \leq V_{IN} \leq 36\text{V}$	2.46	2.50	2.54	V
Line Regulation	$4.5\text{V} \leq V_{IN} \leq 36\text{V}$		0.01	0.015	%/V
Load Regulation	$-2.0\text{mA} \leq I_{REF} \leq 2\text{mA}, V_{IN} = 12\text{V}$		0.3	0.6	%
Output Source Current	$V_{IN} = 5\text{V}$	2	4		mA
Output Sink Current	$V_{IN} = 5\text{V}$	2	4		mA
Temperature Stability			1		%
<b>Regulator</b>					
Supply Current	$V_{IN} = 6\text{V}, I_{OUT} \leq 100\text{mA}$ $V_{IN} = 36\text{V}, I_{OUT} \leq 100\text{mA}$ $V_{IN} = 12\text{V}, I_{OUT} = 125\text{mA}$		20 30 11	25 40 20	$\mu\text{A}$ $\mu\text{A}$ mA
Output Current	$(V_{IN} - V_{OUT}) \geq 1\text{V}, V_{IN} \geq 6\text{V}$	125			mA
Load Regulation	$(V_{IN} - V_{OUT}) \geq 1\text{V}, V_{IN} \geq 6\text{V}$		0.2	0.5	%
Line Regulation	$6\text{V} \leq V_{IN} \leq 36\text{V}$		0.01	0.015	%/V
Dropout Voltage	$I_{OUT} = 100\text{mA}$ $I_{OUT} = 125\text{mA}$		0.02 0.40	0.05 0.65	V V
Feedback Sense Voltage	$V_{IN} = 12\text{V}$	2.44	2.5	2.56	V
Shutdown Pin Voltage	$V_{OUT} \leq 0.5\text{V}$			0.4	V
	Normal				V
	Shutdown	2.2	1.4		V
Shutdown Pin Current	$V_{IN} = 1.4\text{V}$		10		$\mu\text{A}$
Feedback Bias Current			15	40	nA
Minimum Load Current	$V_{IN} = 36\text{V}$		1	5	$\mu\text{A}$
Short-Circuit Current	$V_{IN} = 36\text{V}$		250	400	mA
<b>Comparator</b>					
Offset Voltage	$V_{IN} = 36\text{V}$		3	7	mV
Bias Current	$V_{IN} = 36\text{V}$		15	40	nA
Gain	$\Delta V_{OUT} = 29\text{V}, R_L = 20\text{k}$	2000	10000		V/V
Power Supply Rejection	$4.5\text{V} \leq V_S \leq 36\text{V}$	80	96		dB
Output Sink Current	$V_{IN} = 4.5\text{V}$	10	18		mA
Saturation Voltage	$I_{OUT} = 1\text{mA}$		0.4	0.6	V
Input Voltage Range		0		$V_{IN} - 1$	V
Response Time			5		$\mu\text{s}$
Leakage Current	$V_{IN} = 36\text{V}, V(\text{Pin } 7) = 36\text{V}$			2	$\mu\text{A}$

1120afa

# ELECTRICAL CHARACTERISTICS

The ● denotes the specifications which apply over the full operating temperature range of  $T_J = 25^\circ\text{C}$ .

PARAMETER	CONDITIONS		MIN	TYP	MAX	UNITS
<b>Reference</b>						
Reference Voltage	$4.5\text{V} \leq V_{IN} \leq 36\text{V}$	●	2.40	2.50	2.55	V
Line Regulation	$4.5\text{V} \leq V_{IN} \leq 36\text{V}$	●		0.01	0.02	%/V
Load Regulation	$-2.0\text{mA} \leq I_{REF} \leq 2\text{mA}, V_{IN} = 12\text{V}$	●		0.4	0.8	%
Output Source Current	$V_{IN} = 5\text{V}$	●	2			mA
Output Sink Current	$V_{IN} = 5\text{V}$	●	2			mA
<b>Regulator</b>						
Supply Current	$V_{IN} = 6\text{V}, I_{OUT} \leq 100\mu\text{A}$	●		30	40	$\mu\text{A}$
	$V_{IN} = 36\text{V}, I_{OUT} \leq 100\mu\text{A}$	●		40	50	$\mu\text{A}$
	$V_{IN} = 12\text{V}, I_{OUT} = 125\text{mA}$	●		11	20	mA
Output Current	$(V_{IN} - V_{OUT}) \geq 1\text{V}, V_{IN} \geq 6\text{V}$	●	125			mA
Load Regulation	$(V_{IN} - V_{OUT}) \geq 1\text{V}, V_{IN} \geq 6\text{V}$	●			1	%
Line Regulation	$6\text{V} \leq V_{IN} \leq 36\text{V}$	●			0.02	%/V
Dropout Voltage	$I_{OUT} = 100\mu\text{A}$	●			0.06	V
	$I_{OUT} = 125\text{mA}$	●			0.85	V
Feedback Sense Voltage	$V_{IN} = 12\text{V}$	●	2.38	2.5	2.57	V
Feedback Bias Current		●			50	nA
Minimum Load Current	$V_{IN} = 36\text{V}$	●			50	$\mu\text{A}$
Short-Circuit Current	$V_{IN} = 36\text{V}$	●		240	400	mA
<b>Comparator</b>						
Offset Voltage	$V_{IN} = 36\text{V}$	●			10	mV
Bias Current	$V_{IN} = 36\text{V}$	●		15	60	nA
Gain	$\Delta V_{OUT} = 29\text{V}, R_L = 20\text{k}$	●	1000			V/V
Output Sink Current (Note 2)	$V_{IN} = 4.5\text{V}$	●	5	10		mA
Leakage Current	$V_{IN} = 36\text{V}, V(\text{Pin } 7) = 36\text{V}$	●			8	$\mu\text{A}$

**Note 1:** Absolute Maximum Ratings are those values beyond which the life to the device may be impaired.

**Note 2:** For  $T_A \leq -40^\circ\text{C}$  output sink current drops to 2.5mA.

# TYPICAL PERFORMANCE CHARACTERISTICS

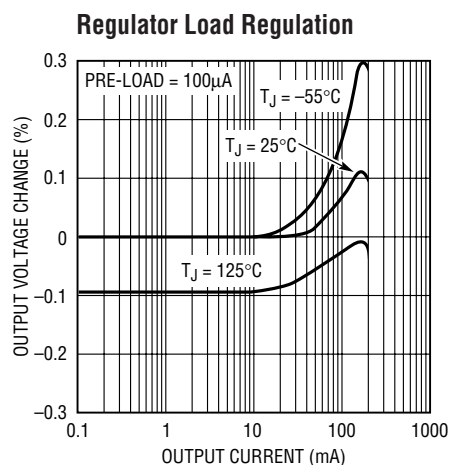

1120A G01

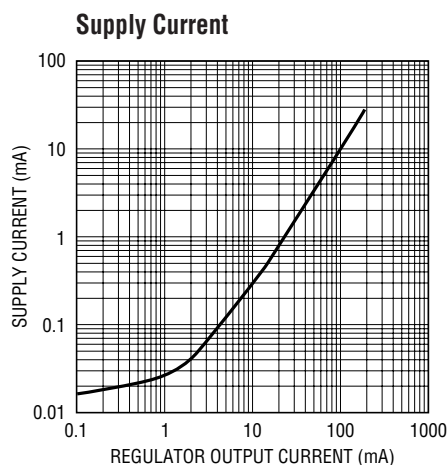

1120A G02

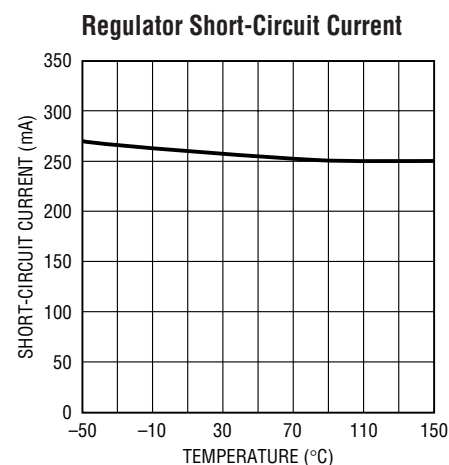

1120A G03

1120afa

# TYPICAL PERFORMANCE CHARACTERISTICS

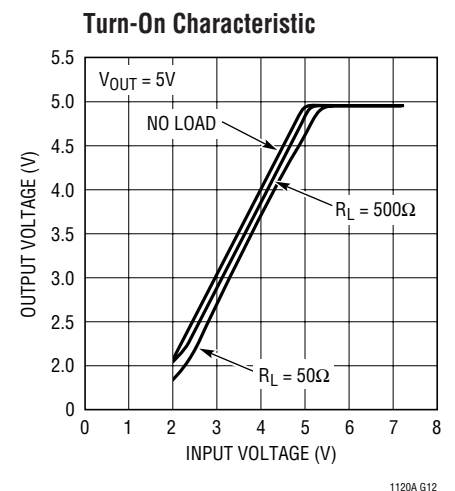
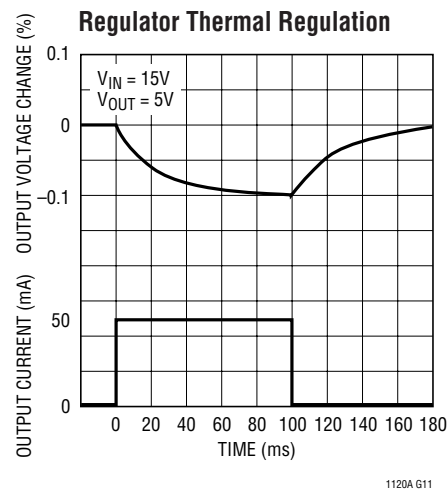
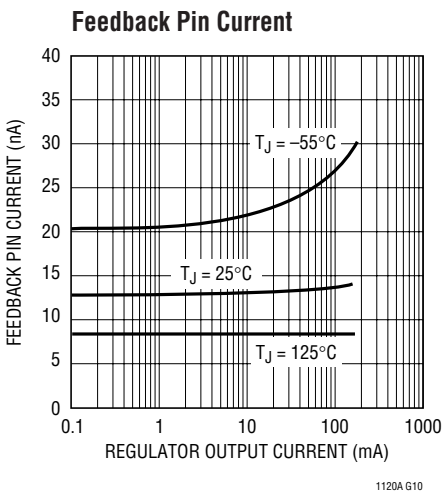
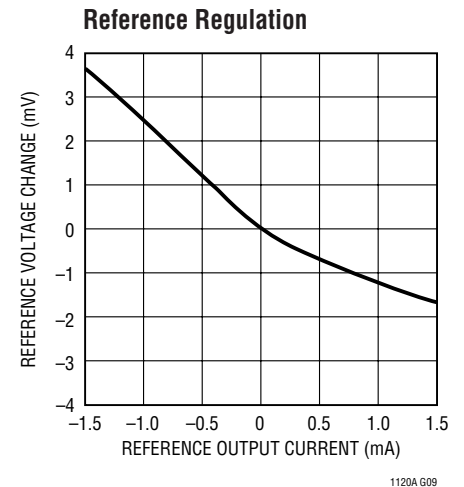
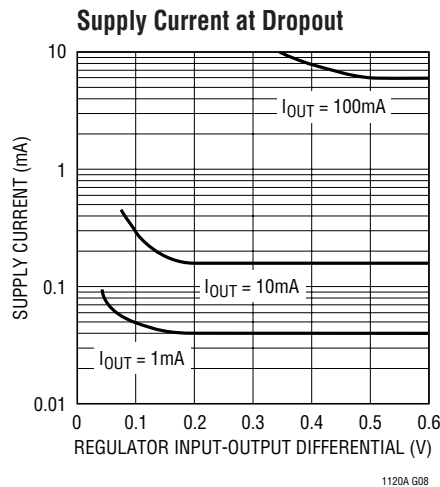
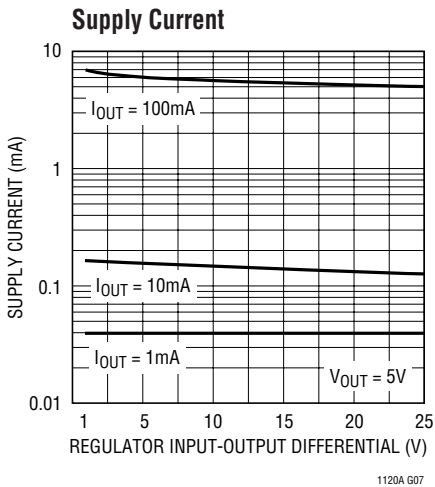
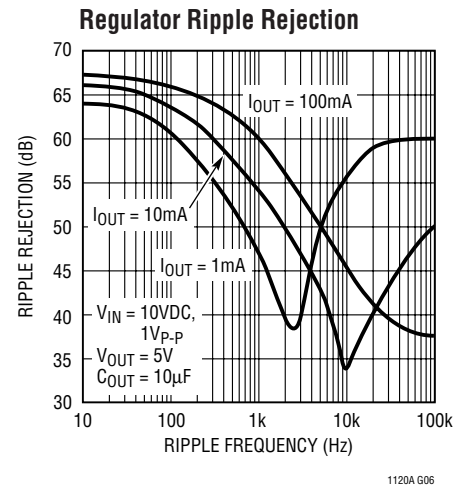
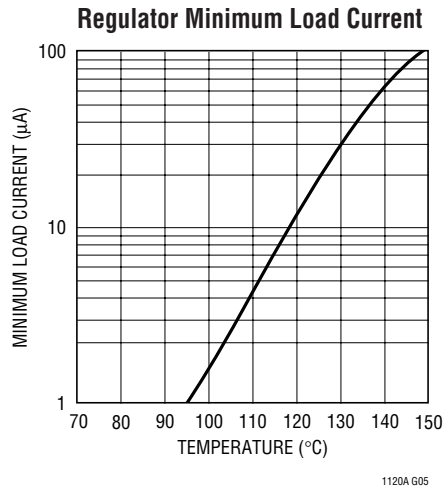
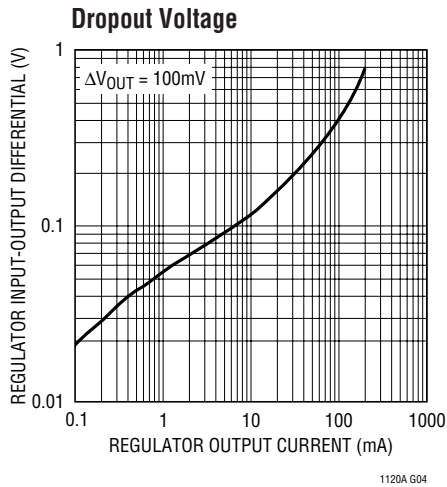

## PIN FUNCTIONS

**GND (Pin 1):** Ground

**FEEDBACK (Pin 2):** This is the feedback point of the regulator. When operating, it is nominally at 2.5V. Optimum source resistance is 200k to 500k. The feedback pin should not be driven below ground or more positive than 5V.

**SHUTDOWN (Pin 3):** A logic 1 shuts off main regulator. Caution: noise or leakage into the shutdown pin can affect output voltage.

**V<sub>OUT</sub> (Pin 4):** Main output, requires 10 $\mu$ F output capacitor. Can be shorted to V<sub>IN</sub> or ground without damaging device.

**V<sub>IN</sub> (Pin 5):** Input Supply. Bypass with 10 $\mu$ F capacitor. Must always be more positive than ground.

**REF (Pin 6):** Reference. 2.5V can source or sink current. May be shorted to ground or up to 5V. Voltages in excess of 5V can damage the device.

**COMP OUT (Pin 7):** Open Collector NPN Output. May be connected to any voltage from ground to 36V more positive than ground (operates above V<sub>IN</sub>). Short-circuit protected.

**-INPUT (Pin 8):** Inverting Comparator Input.

## BLOCK DIAGRAM

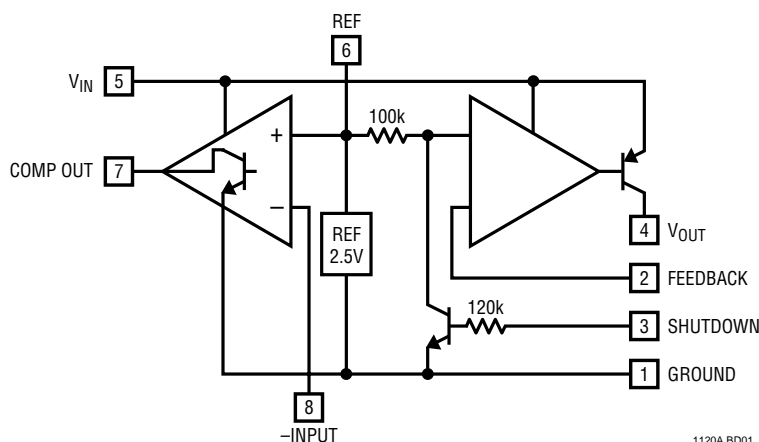

## APPLICATIONS INFORMATION

The LT1120A is especially suited for micropower system applications. For example, the comparator section of the LT1120A may be used as a battery checker to provide an indication of low battery. Another type of system application for the LT1120A would be to generate the equivalent of split supplies off of a single power input. The regulator section provides regulated output voltage and the reference, which can both source and sink current is then an artificial system ground providing a split supply for the system.

For many applications the comparator can be frequency compensated to operate as an amplifier. Compensation values for various gains are given in the data sheet. The comparator gain is purposely low to make it easier to frequency compensate as an amplifier. The NPN output is capable of sinking 10mA and can drive loads connected to voltages in excess of the positive power supply. This is useful for driving switches or linear regulators off of a higher input voltage.

## APPLICATIONS INFORMATION

### Reference

Internal to the LT1120A is a 2.5V trimmed class B output reference. The reference was designed to be able to source or sink current so it could be used in supply splitting applications as well as a general purpose reference for external circuitry. The design of the reference allows it to source and sink typically 4mA. The available source and sink current decreases as temperature increases. It is sometimes desirable to decrease the AC output impedance by placing an output capacitor on Pin 6. The reference in the LT1120A becomes unstable with large capacitive loads placed directly on it. When using an output capacitor, about  $20\Omega$  should be used to isolate the capacitor from the reference pin. This  $20\Omega$  resistor can be placed directly in series with the capacitor or alternatively the reference line can have  $20\Omega$  placed in series with it and then a capacitor to ground. This is shown in Figure 1. Other than placing large capacitive loads on the reference, no other precautions are necessary and the reference is stable with nominal stray capacitances.

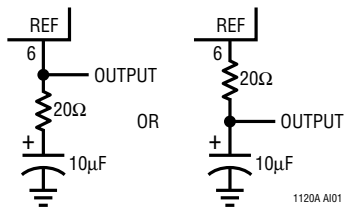

Figure 1. Bypassing Reference

### Overload Protection

The main regulator in the LT1120A is current limited at approximately 250mA. The current limit is stable with both input voltage and temperature.

Like most other IC regulators, a minimum load is required on the output of the LT1120A to maintain regulation. For most standard regulators this is normally specified at 5mA. Of course, for a micropower regulator this would be a tremendously large current. The output current must be large enough to absorb all the leakage current of the pass transistor at the maximum operating temperature. It also affects the transient response; low output currents have long recovery times from load transients. At high operating temperatures the minimum load current increases and having too low of a load current may cause the output to go unregulated. Devices are tested for minimum load current at high temperature. The output voltage setting resistors to the feedback terminal can usually be used to provide the minimum load current.

### Frequency Compensation

The LT1120A is frequency compensated by a dominant pole on the output. An output capacitor of  $10\mu\text{F}$  is usually large enough to provide good stability. **Increasing the output capacitor above  $10\mu\text{F}$  further improves stability.** In order to ensure stability, a feedback capacitor is needed between the output pin and the feedback pin. This is because stray capacitance can form another pole with the large value of feedback resistors used with the LT1120A. Also, a feedback capacitor minimizes noise pickup and improves ripple rejection.

With the large dynamic operating range of the output current, 10000:1, frequency response changes widely. Low AC impedance capacitors are needed to insure stability. While solid tantalum are best, aluminum electrolytics can be used but larger capacitor values may be needed.

# TYPICAL APPLICATIONS

## Regulator with Output Voltage Monitor

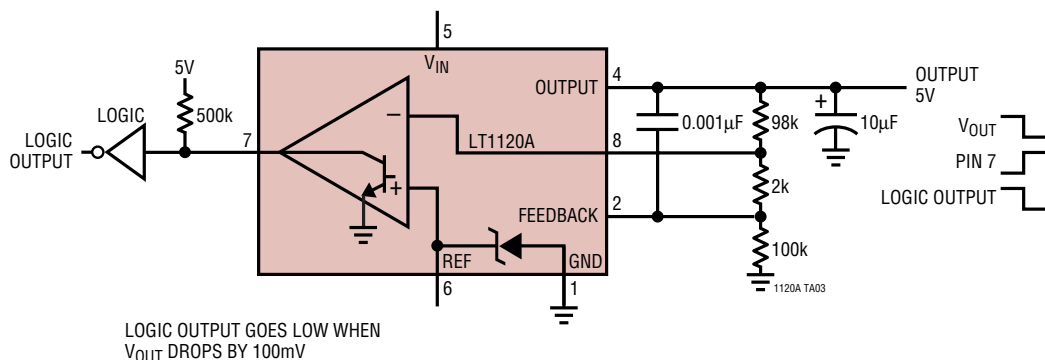

## Compensating the Comparator as an Op Amp

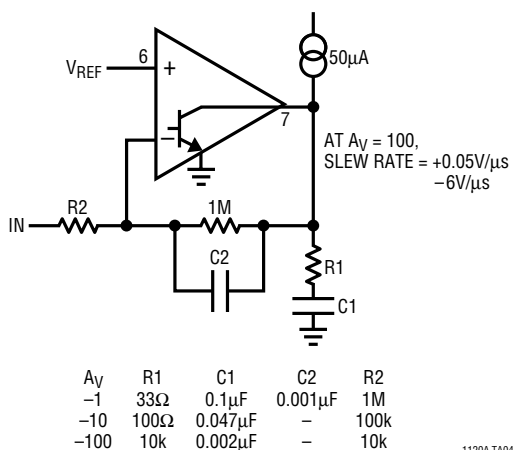

## Current Limited 1 Amp Regulator

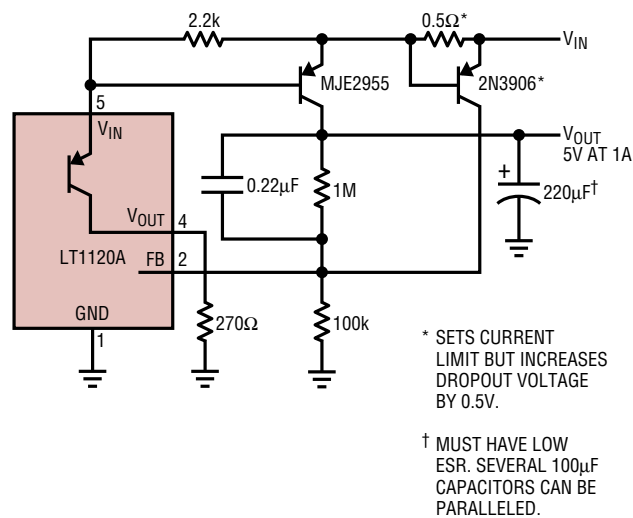

## Battery Backup Regulator

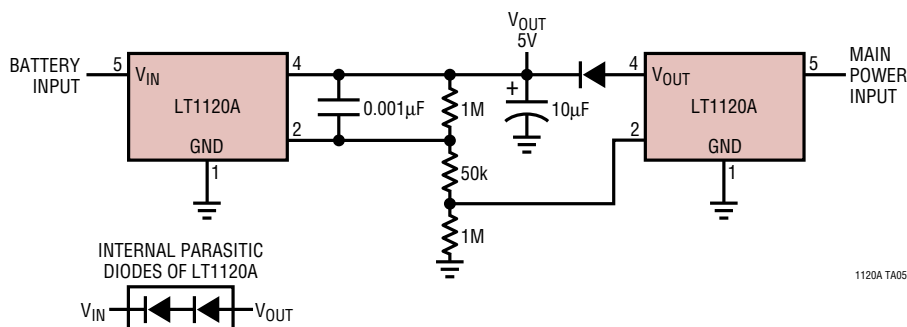

# PACKAGE DESCRIPTION

## N8 Package 8-Lead PDIP (Narrow .300 Inch) (Reference LTC DWG # 05-08-1510)

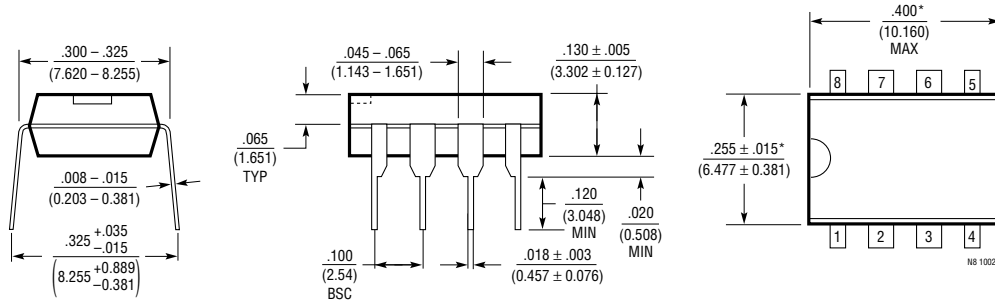

NOTE:  
1. DIMENSIONS ARE IN INCHES / MILLIMETERS  
\*THESE DIMENSIONS DO NOT INCLUDE MOLD FLASH OR PROTRUSIONS.  
MOLD FLASH OR PROTRUSIONS SHALL NOT EXCEED .010 INCH (0.254mm)

## S8 Package 8-Lead Plastic Small Outline (Narrow .150 Inch) (Reference LTC DWG # 05-08-1610)

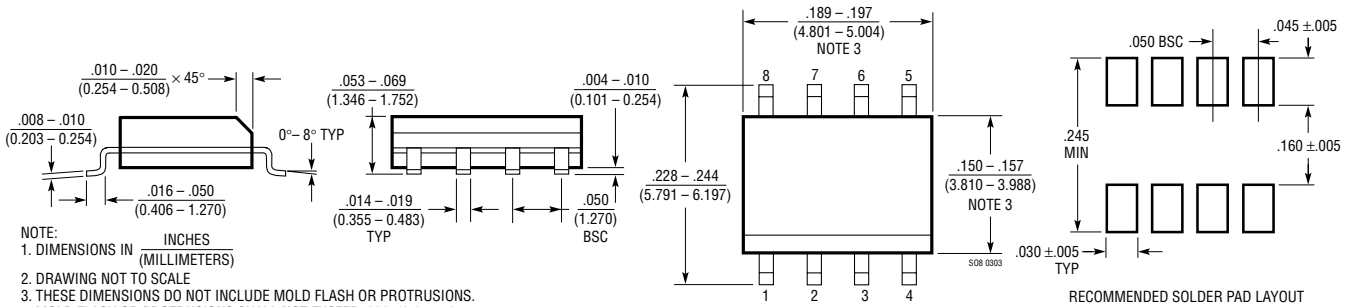

NOTE:  
1. DIMENSIONS IN INCHES / (MILLIMETERS)  
2. DRAWING NOT TO SCALE  
3. THESE DIMENSIONS DO NOT INCLUDE MOLD FLASH OR PROTRUSIONS.  
MOLD FLASH OR PROTRUSIONS SHALL NOT EXCEED .006 (0.15mm)

## RELATED PARTS

PART NUMBER	DESCRIPTION	COMMENTS
LT1761/LT1762	100mA/150mA, Low Noise Micropower, LDO	$V_{IN}$ : 1.8V to 20V; $V_{OUT(MIN)}$ = 1.22V; Dropout Voltage = 0.30V; $I_Q$ = 20 $\mu$ A; $I_{SD}$ < 1 $\mu$ A; $V_{OUT}$ = Adj, 1.5V, 1.8V, 2V, 2.5V, 2.8V, 3V, 3.3V, 5V; ThinSOT™/MS8 Packages. Low Noise <20 $\mu$ V <sub>RMS</sub> -P
LT1763	500mA, Low Noise Micropower, LDO	$V_{IN}$ : 1.8V to 20V; $V_{OUT(MIN)}$ = 1.22V; Dropout Voltage = 0.30V; $I_Q$ = 30 $\mu$ A; $I_{SD}$ < 1 $\mu$ A; $V_{OUT}$ = 1.5V, 1.8V, 2.5V, 3V, 3.3V, 5V; SO-8 Package. Low Noise <20 $\mu$ V <sub>RMS</sub> -P
LT1764/LT1764A	3A, Low Noise, Fast Transient Response, LDO	$V_{IN}$ : 2.7V to 20V; $V_{OUT(MIN)}$ = 1.21V; Dropout Voltage = 0.34V; $I_Q$ = 1mA; $I_{SD}$ < 1 $\mu$ A; $V_{OUT}$ = 1.8V, 2.5V, 3.3; DD, TO220, Packages. Low Noise <40 $\mu$ V <sub>RMS</sub> -P, "A" Version Stable with Ceramic Capacitors
LT1962	300mA, Low Noise Micropower, LDO	$V_{IN}$ : 1.8V to 20V; $V_{OUT(MIN)}$ = 1.22V; Dropout Voltage = 0.27V; $I_Q$ = 30 $\mu$ A; $I_{SD}$ < 1 $\mu$ A; $V_{OUT}$ = 1.5V, 1.8V, 2.5V, 3V, 3.3V, 5V; MS8 Package. Low Noise <20 $\mu$ V <sub>RMS</sub> -P
LT1963/LT1963A	1.5A, Low Noise, Fast Transient Response, LDO	$V_{IN}$ : 2.1V to 20V; $V_{OUT(MIN)}$ = 1.21V; Dropout Voltage = 34V; $I_Q$ = 1mA; $I_{SD}$ < 1 $\mu$ A; $V_{OUT}$ = 1.5V, 1.8V, 2.5V, 3.3; DD, TO220, SOT-223, SO-8 Packages. Low Noise <40 $\mu$ V <sub>RMS</sub> -P, "A" Version Stable with Ceramic Capacitors
LT1964	200mA, Low Noise Micropower Negative, LDO	$V_{IN}$ : -0.9V to -20V; $V_{OUT(MIN)}$ = -1.21V; Dropout Voltage = 0.34V; $I_Q$ = 30 $\mu$ A; $I_{SD}$ < 3 $\mu$ A; $V_{OUT}$ = Adj, -5V; ThinSOT Package. Low Noise <30 $\mu$ V <sub>RMS</sub> -P, Stable with Ceramic Capacitors
LT3010	80V, 50mA, Low Noise Linear Regulator	$V_{IN}$ : 1.5V to 80V; $V_{OUT(MIN)}$ = 1.28V; Dropout Voltage = 0.30V; $I_Q$ = 30 $\mu$ A; $I_{SD}$ < 1 $\mu$ A; $V_{OUT}$ = Adj, -5V; MS8E Package. Low Noise <100 $\mu$ V <sub>RMS</sub> -P, Stable with Ceramic Capacitors

ThinSOT is a trademark of Linear Technology Corporation.