

### Features

- 0.85V maximum dropout voltage at 4A load current
- Built-in Thermal shutdown
- Output current limiting
- Adjustable or fixed output voltage 1.5V, 1.8V, 2.5V, 3.3V, 5.0V
- Fast transient response
- Good noise rejection
- Packages: TO220-5L and TO263-5L
- Lead Free Finish/ RoHS Compliant (Note 1)

### General Description

AP1184 is a 4A regulator with extremely low dropout voltage. This product is specifically designed to provide well regulated supply for applications requiring 2.8V or lower voltages from 3.3V ATX power supplies where high efficiency of the switch can be achieved without the cost and complexity associated with switching regulator. One such application is the new graphic chipsets that requires anywhere from 2.4V to 2.7V supply.

### Ordering Information

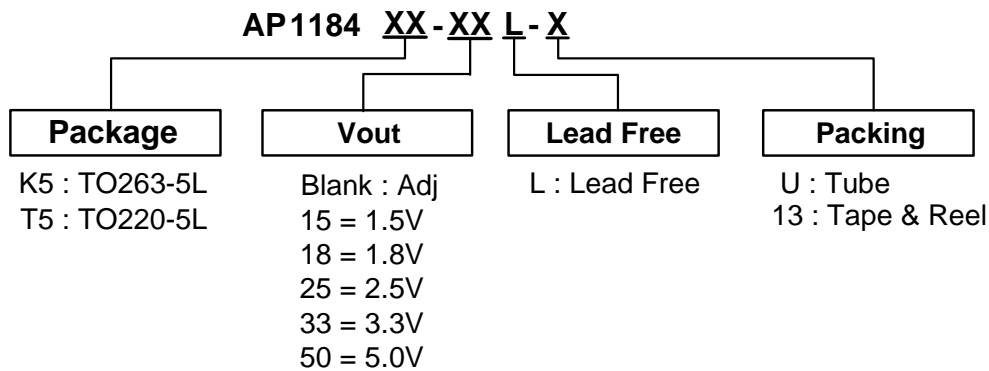

Device	Package Code	Packaging (Note 2)	Tube		13" Tape and Reel	
			Quantity	Part Number Suffix	Quantity	Part Number Suffix
AP1184K5XXL-U	K5	TO263-5L	50	-U	NA	NA
AP1184K5XXL-13	K5	TO263-5L	NA	NA	800/Tape & Reel	-13
AP1184T5XXL-U	T5	TO220-5L	50	-U	NA	NA

Notes: 1. EU Directive 2002/95/EC (RoHS). All applicable RoHS exemptions applied, see *EU Directive 2002/95/EC Annex Notes*.  
 2. Pad layout as shown on Diodes Inc. suggested pad layout document AP02001, which can be found on our website at <http://www.diodes.com/datasheets/ap02001.pdf>.

### Pin Assignments

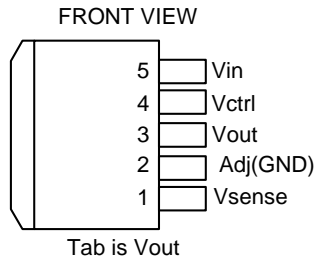

**TO263-5L**

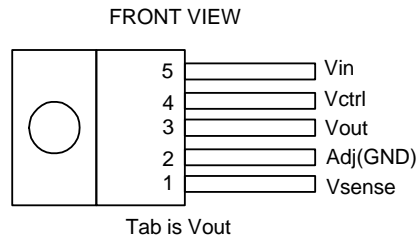

**TO220-5L**

### Pin Descriptions

Pin Numbers with standard type are for TO220-5L, TO263-5L packages.

Name	I/O	Description
Adj (GND)		A resistor divider from this pin to the Vout pin and ground sets the output voltage. (GND only for fixed mode)
Vsense	I	This pin is the positive side of the reference that allows remote load sensing to achieve excellent load regulation. A minimum of 10uF capacitor must be connected from this pin to ground to insure stability.
Vin	I	The input of the regulator. Typically a large storage capacitor is connected from this pin to ground to insure that the input voltage does not sag below the minimum dropout voltage during the load transient response. This pin must always be higher than Vout in order for the device to regulate.
Vctrl	I	This pin is the supply pin for the internal control circuit as well as the base drive for the pass transistor. This pin must always be higher than the Vout pin in order to regulate the device. A minimum of 100uF capacitor must be connected from this pin to ground to insure stability.
Vout	O	The output of the regulator. A minimum of 100uF capacitor must be connected from this pin to ground to insure stability.

### Block Diagram

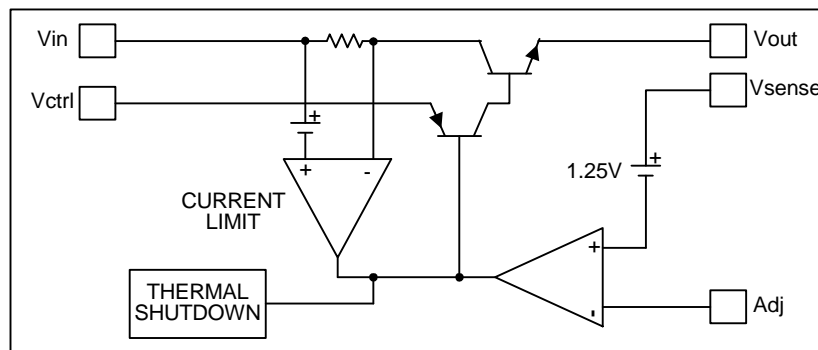

**Typical Application Circuit**

**(1) Adjustable Regulator**

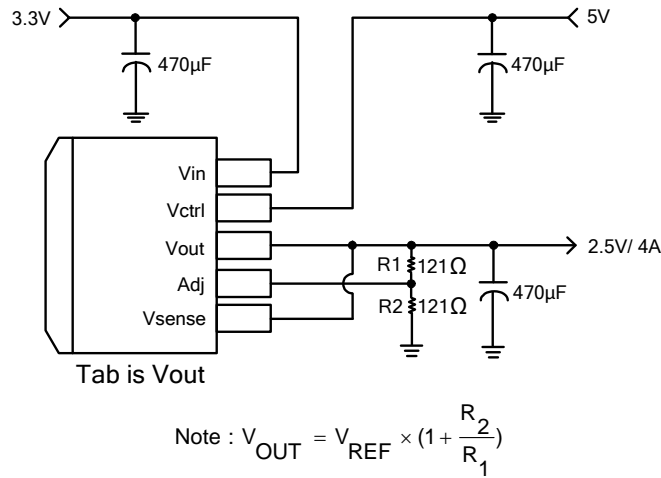

**(2) 3.3V to 2.5V Fixed Mode Regulator**

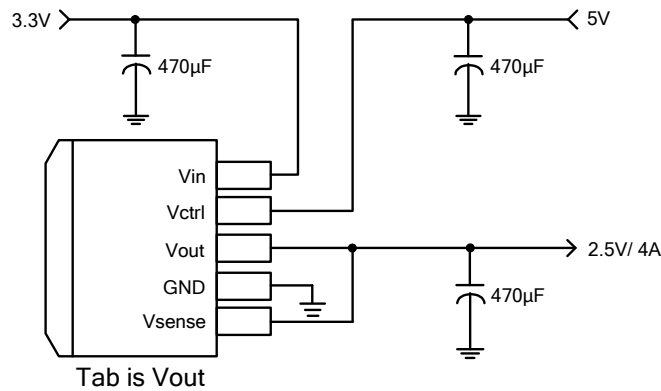

**Absolute Maximum Ratings**

Symbol	Parameter	Rating	Unit
$V_{IN}$	Input Voltage	16	V
$V_{ctrl}$	Control Input voltage	18	V
$P_D$	Power dissipation	Internally limited	
$T_{ST}$	Storage temperature Range	-65 to +150	°C
$T_{OP}$	Operation Junction Temperature Range	0 to +125	°C

### Electrical Characteristics (Under Operating Conditions)

Unless otherwise specified, these specifications apply over,  $C_{in} = 1\mu F$ ,  $C_{out} = 10\mu F$ , and  $T_j = 0$  to  $150^\circ C$ . Typical value refer to  $T_A = 25^\circ C$ .

$$V_{out} = V_{sense}$$

Sym.	Parameter	Test Condition	Min	Typ.	Max	Unit
$V_{REF}$	Reference Voltage	AP1184-Adj $I_o = 10mA, T_A = 25^\circ C, (V_{in} - V_{out}) = 0.7V,$ $V_{ctrl} = V_{IN} + 1V$	1.225	1.250	1.275	V
	Line Regulation	AP1184-XXX $I_o = 10mA, V_{OUT} + 0.7V < V_{IN} < 12V, T_A = 25^\circ C$ $V_{ctrl} = V_{IN} + 1V$			0.2	%
$V_{out}$	Output Voltage	AP1184-1.5 $I_{OUT} = 10mA, T_A = 25^\circ C, 2.2V \leq V_{IN} \leq 12V$ $V_{ctrl} = V_{IN} + 1V$	1.470	1.500	1.530	V
		AP1184-1.8 $I_{OUT} = 10mA, T_A = 25^\circ C, 2.5V \leq V_{IN} \leq 12V$ $V_{ctrl} = V_{IN} + 1V$	1.764	1.800	1.836	V
		AP1184-2.5 $I_{OUT} = 10mA, T_A = 25^\circ C, 3.2V \leq V_{IN} \leq 12V$ $V_{ctrl} = V_{IN} + 1V$	2.450	2.500	2.550	V
		AP1184-3.3 $I_{OUT} = 10mA, T_A = 25^\circ C, 4.0V \leq V_{IN} \leq 12V$ $V_{ctrl} = V_{IN} + 1V$	3.235	3.300	3.365	V
		AP1184-5.0 $I_{OUT} = 10mA, T_A = 25^\circ C, 5.7V \leq V_{IN} \leq 12V$ $V_{ctrl} = V_{IN} + 1V$	4.900	5.000	5.100	V
	Load Regulation	AP1184-Adj $0mA < I_o < 4A, T_A = 25^\circ C$ $(V_{IN} - V_{OUT}) = 2V, V_{ctrl} = V_{IN} + 1V$			1	%
		AP1184-1.5 $V_{IN} = 3V, 0mA < I_o < 4A, T_A = 25^\circ C$ $V_{ctrl} = 4V$		12	15	mV
		AP1184-1.8 $V_{IN} = 3.3V, 0mA < I_o < 4A, T_A = 25^\circ C$ $V_{ctrl} = 4.3V$		15	18	mV
		AP1184-2.5 $V_{IN} = 4V, 0mA < I_o < 4A, T_A = 25^\circ C$ $V_{ctrl} = 5V$		20	25	mV
		AP1184-3.3 $V_{IN} = 5V, 0mA < I_o < 4A, T_A = 25^\circ C$ $V_{ctrl} = 6V$		26	33	mV
		AP1184-5.0 $V_{IN} = 8V, 0mA < I_o < 4A, T_A = 25^\circ C$ $V_{ctrl} = 9V$		40	50	mV
	Dropout Voltage ( $V_{ctrl} - V_{out}$ )	$V_{adj} = 0V$ for all conditions below. $V_{in} = 2.05V, I_o = 1.5A$ $V_{in} = 2.05V, I_o = 3A$ $V_{in} = 2.05V, I_o = 4A$		1.10	1.15 1.18 1.25	V
	Dropout Voltage ( $V_{in} - V_{out}$ )	$V_{adj} = 0V$ for all conditions below. $V_{ctrl} = 2.75V, I_o = 1.5A$ $V_{ctrl} = 2.75V, I_o = 3A$ $V_{ctrl} = 2.75V, I_o = 4A$		0.26 0.50 0.70	0.38 0.60 0.85	V
	Current Limit	$V_{ctrl} = 2.75V, V_{in} = 2.05V, \Delta V_o = 100mV, V_{adj} = 0V$	4.2			A
	Minimum Load Current	$V_{ctrl} = 5V, V_{in} = 3.3V, V_{adj} = 0V$		5	10	mA
	Thermal Regulation	30mS Pulse		0.01	0.02	%/W
	Ripple Rejection	$V_{ctrl} = 5V, V_{in} = 5V, I_o = 4A, V_{adj} = 0V, T_j = 25, V_{ripple} = 1V_{pp}$ at 120Hz	60	70		dB
	Control Pin Current	$V_{adj} = 0V$ for all conditions below. $V_{ctrl} = 2.75V, V_{in} = 2.05V, I_o = 1.5A$ $V_{ctrl} = 2.75V, V_{in} = 2.05V, I_o = 3A$ $V_{ctrl} = 2.75V, V_{in} = 2.05V, I_o = 4A$		6 30 33	25 60 70	mA

### Electrical Characteristics (Continued)

Unless otherwise specified, these specifications apply over,  $C_{in} = 1\mu F$ ,  $C_{out} = 10\mu F$ , and  $T_j = 0$  to  $150^\circ C$ . Typical value refer to  $T_A = 25^\circ C$ .

$V_{out} = V_{sense}$ .

Sym.	Parameter	Test Condition	Min	Typ.	Max	Unit
$I_{adj}$	Adjust Pin Current	$V_{ctrl} = 2.75V$ , $V_{in} = 2.05V$ , $V_{adj} = 0$		50	150	$\mu A$
$\theta_{JA}$	Thermal Resistance Junction-to-Ambient	TO263-5L: Control Circuitry/Power Transistor (Note 4) TO220-5L: Control Circuitry/Power Transistor (Note 5)		61 31		$^\circ C/W$ $^\circ C/W$
$\theta_{JC}$	Thermal Resistance Junction-to-Case	TO263-5L: Control Circuitry/Power Transistor (Note 4) TO220-5L: Control Circuitry/Power Transistor (Note 5)		7 5		$^\circ C/W$ $^\circ C/W$

- Notes:
3. AP1184-ADJ incorporates an internal thermal shutdown that protects the device when the junction temperature exceeds the allowable maximum junction temperature.
  4. Test conditions for TO263-5L : Device mounted on 2oz copper, minimum recommended pad layout , FR-4 PCB.
  5. Test conditions for TO220-5L : with copper area of approximately  $3in^2$  , 1oz.

Package	Max Pd.	Remarks
TO263-5L/TO220-5L	2.4W~4.4W	With heat sink or amount of copper board needed.

### Functional Descriptions

#### Introduction

The AP1184 regulator is a 5 terminal device designed specifically to provide extremely low dropout voltages comparable to the PNP type without the disadvantage of the extra power dissipation due to the base current associated with PNP regulators. This is done by bringing out the control pin of the regulator that provides the base current to the power NPN and connecting it to a voltage that is greater than the voltage present at the  $V_{in}$  pin. This flexibility makes the AP1184 ideal for applications where dual inputs are available such as a computer motherboard with an ATX style power supply that provides 5V and 3.3V to the board. One such application is the new graphic chip sets that require anywhere from 2.4V to 2.7V supply. The AP1184 can easily be programmed with the addition of two external resistors to any voltages within the range of 1.25V to 15.5V. Another major requirement of these graphic chips is the need to switch the load current from zero to several amps in tens of nanoseconds at the processor pins, which translates to an approximately 300 to 500ns of current step at the regulator. In addition, the output voltage tolerances are also extremely tight and they include the transient response as part of the specification.

The AP1184 is specifically designed to meet the fast current transient needs as well as providing an accurate initial voltage, reducing the overall system cost with the need for fewer number of output capacitors. Another feature of the device is its true remote sensing capability that allows accurate voltage setting at the load rather than at the device.

#### Output Voltage Setting

The AP1184-ADJ can be programmed to any voltages in the range of 1.25V to 15.5V with the addition of R1 and R2 external resistors according to the following formula:

### Functional Descriptions (Continued)

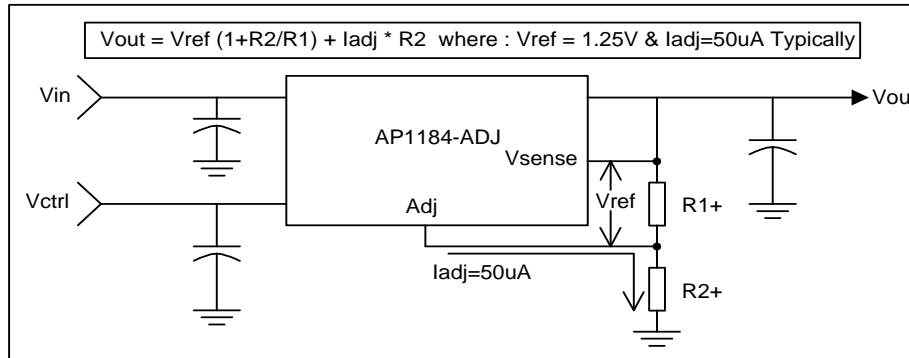

The AP1184-ADJ keeps a constant 1.25V between the Vsense pin and the Adj pin. By placing a resistor R1 across these two pins and connecting the Vsense and Vout pin together, a constant current flows through R1, adding to the Iadj current and into the R2 resistor producing a voltage equal to the  $(1.25/R_1) * R_2 + I_{adj} * R_2$ . This voltage is then added to the 1.25V to set the output voltage. This is summarized in the above equation. Since the minimum load current requirement of the AP1184-ADJ is 10mA, R1 is typically selected to be a 121Ω resistor so that it automatically satisfies this condition. Notice that since the Iadj is typically in the range of 50uA it only adds a small error to the output voltage and should be considered when very precise output voltage setting is required.

#### Load Regulation

Since the AP1184 has separate pins for the output (Vout) and the sense (Vsense), it is ideal for providing true remote sensing of the output voltage at the load. This means that the voltage drops due to parasitic resistance such as PCB traces between the regulator and the load are compensated for using remote sensing. Figure following shows a typical application of the AP1184-ADJ with remote sensing.

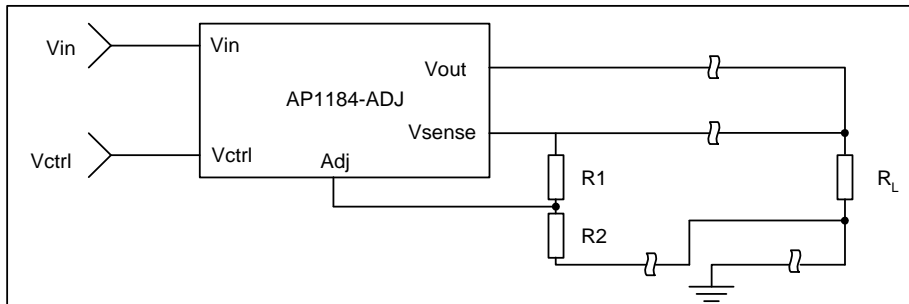

#### Stability

The AP1184-XXX requires the use of an output capacitor as part of the frequency compensation in order to make the regulator stable. Typical designs for the microprocessor applications use standard electrolytic capacitors with typical ESR in the range of 50 to 100mΩ and an output capacitance of 100uF to 1000uF. Fortunately as the capacitance increases, the ESR decreases resulting in a fixed RC time constant. The AP1184-XXX takes advantage of the phenomena in making the overall regulator loop stable. For most applications a minimum of 100uF aluminum electrolytic capacitor insures both stability and good transient response.

#### Thermal Design

The AP1184-XXX incorporates an internal thermal shutdown that protects the device when the junction temperature exceeds the allowable maximum junction temperature. Although this device can operate with junction temperatures in the range of 150°C, it is recommended that the selected heat sink be chosen such that during maximum continuous load operation, the junction temperature is kept below this number. The example below shows the steps in selecting the proper surface mount package.

### Functional Descriptions (Continued)

Assuming, the following conditions:

$$V_{out} = 2.5V$$

$$V_{in} = 3.3V$$

$$V_{ctrl} = 5V$$

$$I_{out} = 2A \text{ DC Avg.}$$

Calculate the maximum power dissipation using the following equation:

$$P_d = I_{out} * (V_{in} - V_{out}) + (I_{out} / 60) * (V_{ctrl} - V_{out})$$

$$P_d = 2 * (3.3 - 2.5) + (2/60) * (5 - 2.5) = 1.68W$$

Using table below select the proper package and the amount of copper board needed.

Package	Copper Area	$\theta_{JA}$ (°C/W)	Max Pd (TA = 25°C)	Max Pd (TA = 45°C)
TO263-5L	Pad Size-1.4"X1.4"	25-45	2.4W-4.4W	2.0W-3.6W

Notes: 6. Above table is based on the maximum junction temperature of 135°C.  
As shown in the above table, any of the two packages will do the job.

**Performance Characteristics**

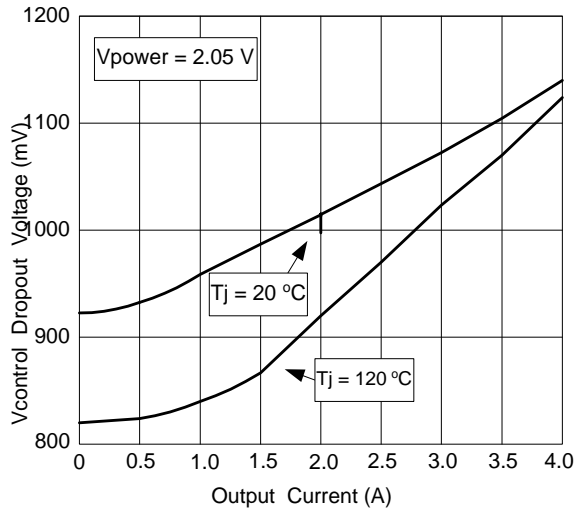

**V<sub>control</sub> Dropout Voltage vs Output Current**

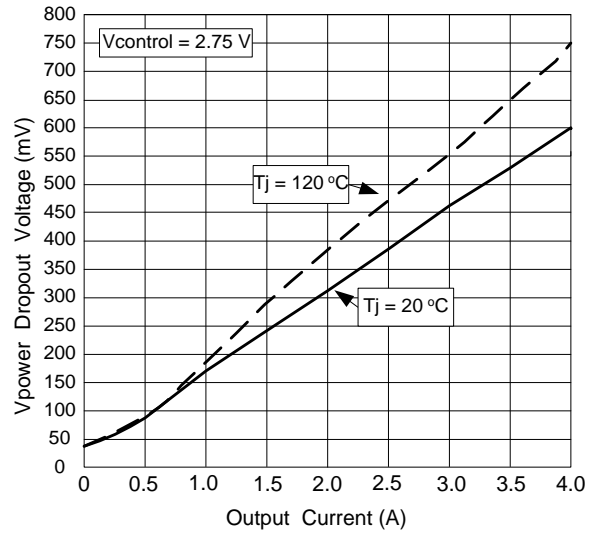

**V<sub>power</sub> Dropout Voltage vs Output Current**

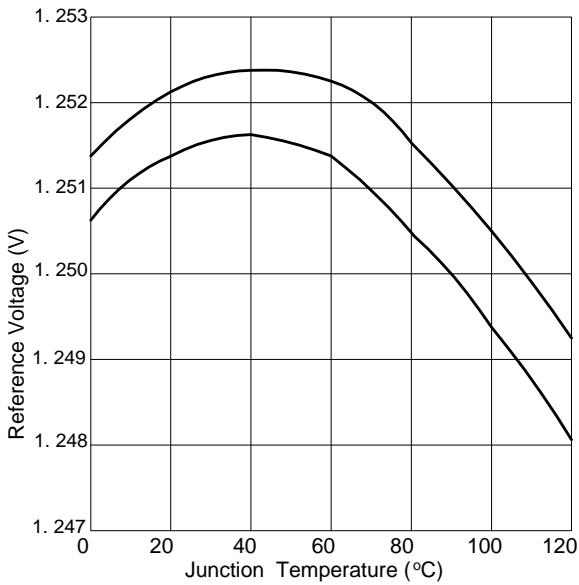

**Reference Voltage vs Junction Temperature**

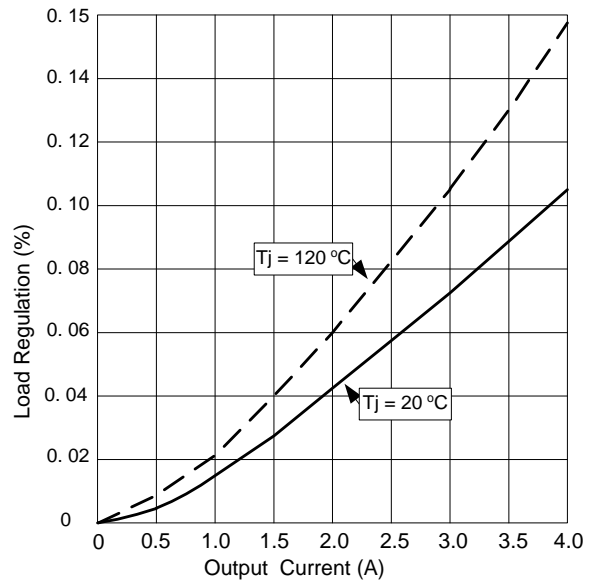

**Load Regulation vs Output Current**



**Performance Characteristic (Continued)**

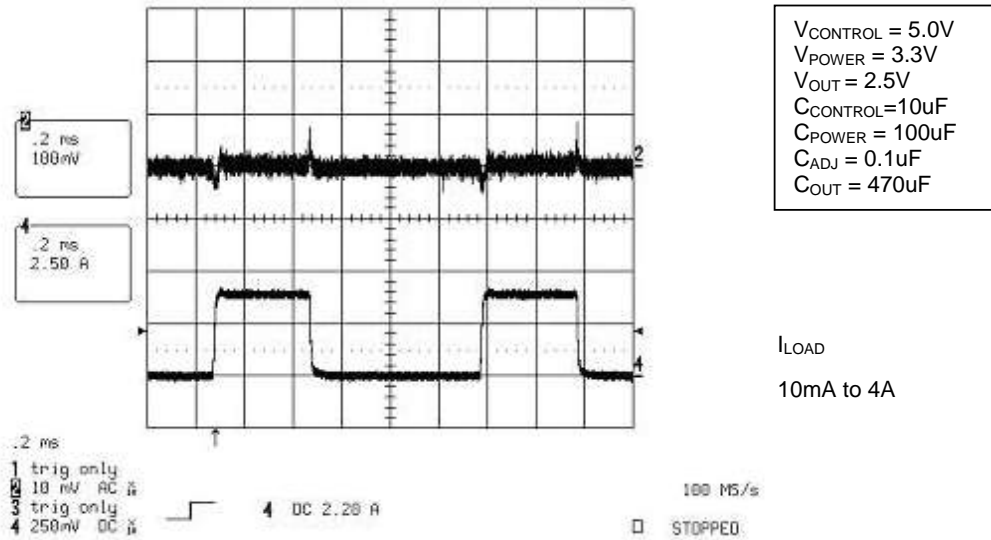

**Transient Response**

**Marking Information**

(1) TO263-5L

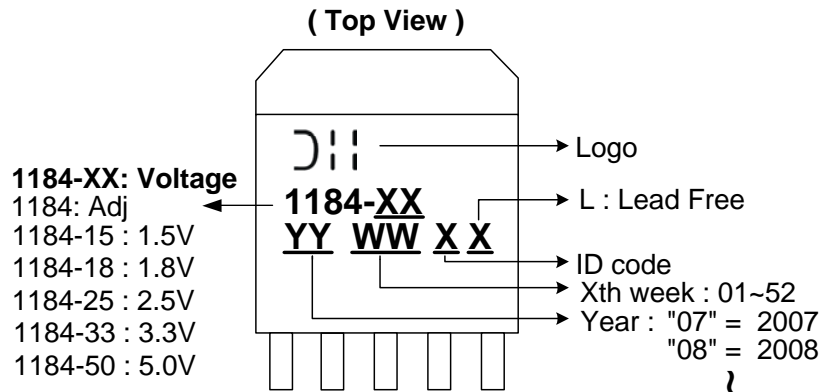

(2) TO220-5L

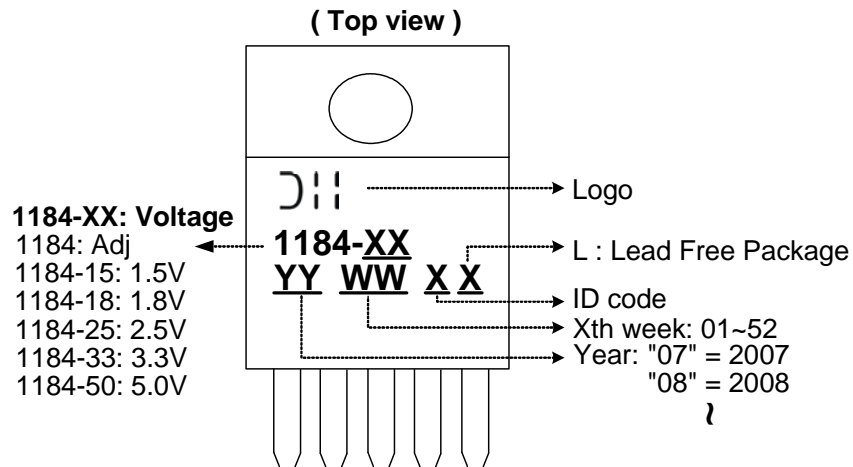

**Package Information (All Dimensions in mm)**

**(1) Package Type: TO263-5L**

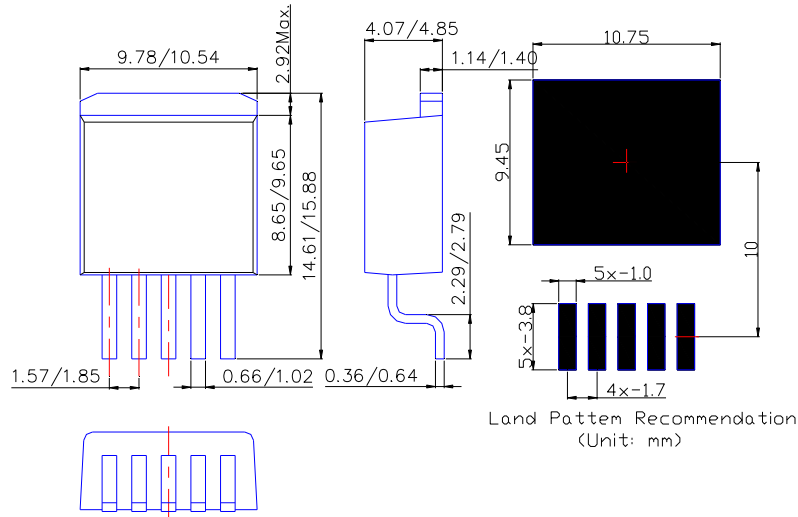

**(2) Package Type: TO220-5L**

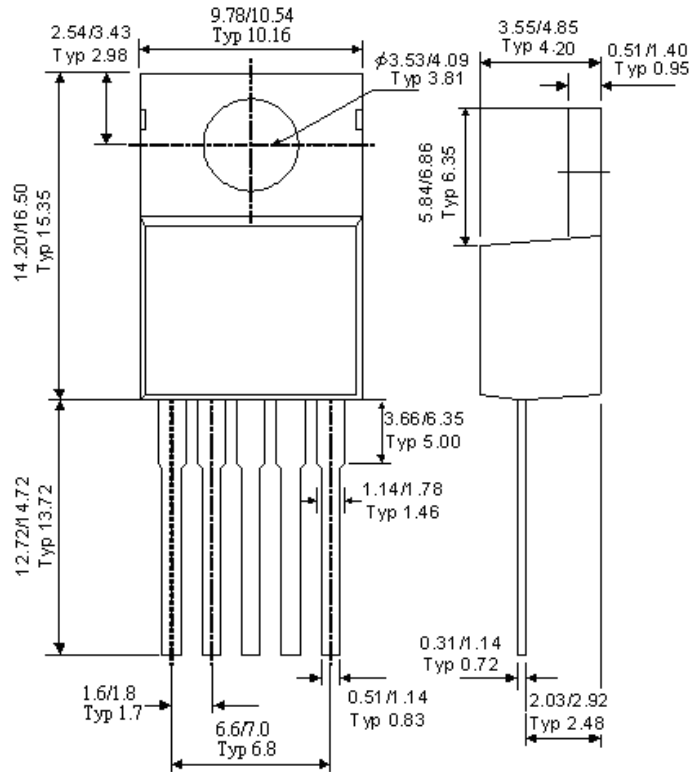

**IMPORTANT NOTICE**

Diodes Incorporated and its subsidiaries reserve the right to make modifications, enhancements, improvements, corrections or other changes without further notice to any product herein. Diodes Incorporated does not assume any liability arising out of the application or use of any product described herein; neither does it convey any license under its patent rights, nor the rights of others. The user of products in such applications shall assume all risks of such use and will agree to hold Diodes Incorporated and all the companies whose products are represented on our website, harmless against all damages.

**LIFE SUPPORT**

Diodes Incorporated products are not authorized for use as critical components in life support devices or systems without the expressed written approval of the President of Diodes Incorporated.