



TS836

MICROPOWER VOLTAGE SUPERVISOR RESET ACTIVE HIGH

- ULTRA LOW POWER CONSUMPTION: 12µA max. at $V_{cc} = 5V$
- PRECISION RESET THRESHOLD (guaranteed over Temperature)
- THRESHOLD VOLTAGE:
4.50V typ. FOR TS836-4
- GUARANTEED RESET OPERATION FOR V_{cc} DOWN TO 1V
- OPEN DRAIN OUTPUT COMPARATOR WITH $V_{ol} = 450mV$ typ. @ $I_{ol} = 8mA$ & $V_{cc} = 4V$
- FAST RESPONSE TIME: 20µs FOR A 10mV OVERDRIVE
- 100mV INTERNAL HYSTERESIS

DESCRIPTION

The TS836 ultra low power integrated circuit incorporates a high stability band-gap voltage reference and a comparator with open drain output.

The threshold voltage is set at 4.5V for TS836-4 by internal thermally matched resistances.

The comparator exhibits a 20µs response (with 10mV overdrive) and has an open drain output active when input voltage is lower than the threshold.

An internal hysteresis of 100mV increases the comparator's noise margin and prevents false reset operation.

APPLICATION

- Power-on reset generator for micro controller
- Power failure detector

ORDER CODE

Part Number	Temperature Range	Package		
		D	Z	P
TS836-4I	-40, +85°C	•	•	•

Z= TO92 Plastic package - also available in Bulk (Z), Tape & Reel (ZT) and Ammo Pack (AP)
 D = Small Outline Package (SO) - also available in Tape & Reel (DT)
 P = Thin Shrink Small Outline Package (TSSOP) - only available in Tape & Reel (PT)

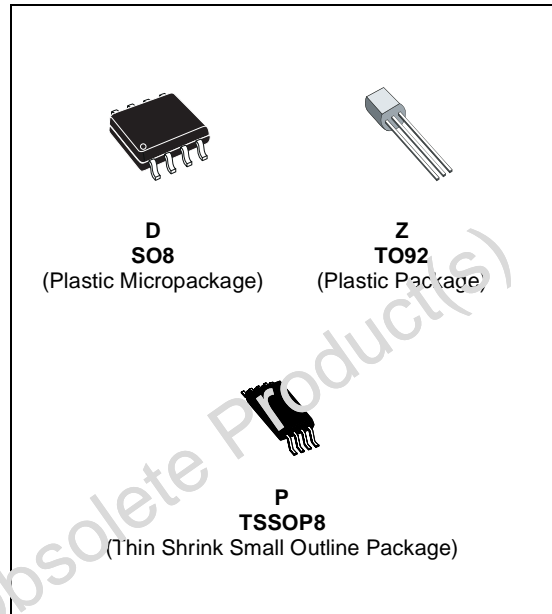

PIN CONNECTIONS (top view)

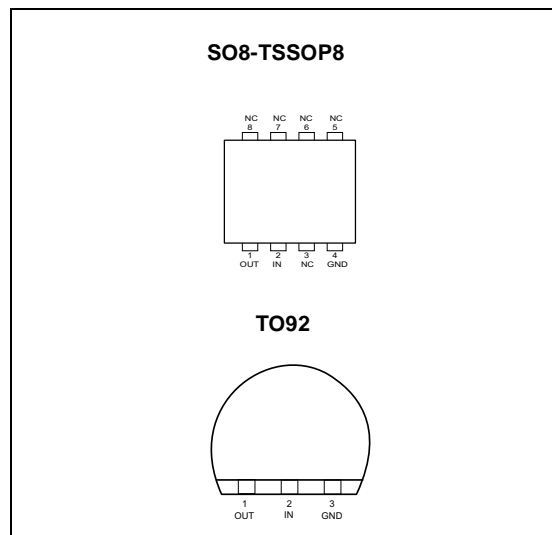

ABSOLUTE MAXIMUM RATINGS

Symbol	Parameter	Value	Unit	
V _{CC}	Supply Voltage ¹⁾	7	V	
V _{OUT}	Output Voltage	-0.3 to V _{CC} + 0.3	V	
I _{OUT}	Output Current	20	mA	
P _D	Power Dissipation ²⁾	SO8 TSSOP8 TO92	700 625 625	mW
T _{STG}	Storage Temperature	-65 to +150	°C	

- All voltages values, except differential voltage are with respect to network ground terminal.
- P_D is calculated with T_{AMB}=+25°C, T_J=+150°C and
 - R_{THJA}= 175°C/W for SO8 package
 - R_{THJA}= 200°C/W for TSSOP8 package
 - R_{THJA}= 200°C/W for TO92 package

OPERATING CONDITIONS

Symbol	Parameter	Value	Unit
V _{CC}	Supply Voltage	1 to 5.5	V
T _{OPER}	Operating Free Air Temperature Range	-40 to +85	°C

TS836-4

ELECTRICAL CHARACTERISTICS Tamb = 25°C (unless otherwise specified)

Symbol	Parameter	Min.	Typ.	Max.	Unit
V _{THi}	Threshold Voltage - V _{CC} Increasing T _{min.} ≤ T _{amb} ≤ T _{max.}	4.17	4.5	4.66	V
V _{THD}	Threshold Voltage - V _{CC} Decreasing T _{min.} ≤ T _{amb} ≤ T _{max.}	4.17	4.4	4.66	V
V _{HYS}	Hysteresis Voltage	50	100	200	mV
I _{CC}	Current Consumption V _{CC} = 5V			12	µA
V _{OL}	Low Level Output Voltage I _{OL} = 8mA, T _{min.} ≤ T _{amb} ≤ T _{max.} V _{CC} = 4V		450	800 1000	mV
I _{OH}	Output Off-state Leakage T _{min.} ≤ T _{amb} ≤ T _{max.} V _{CC} = 5V		2	100 1000	nA
T _{PHL}	Response Time High to Low R _L = 10kΩ, C _L = 15pF, V _{CC} = V _{thd} - 10mV		20		µs

EQUIVALENT SCHEMATIC DIAGRAM

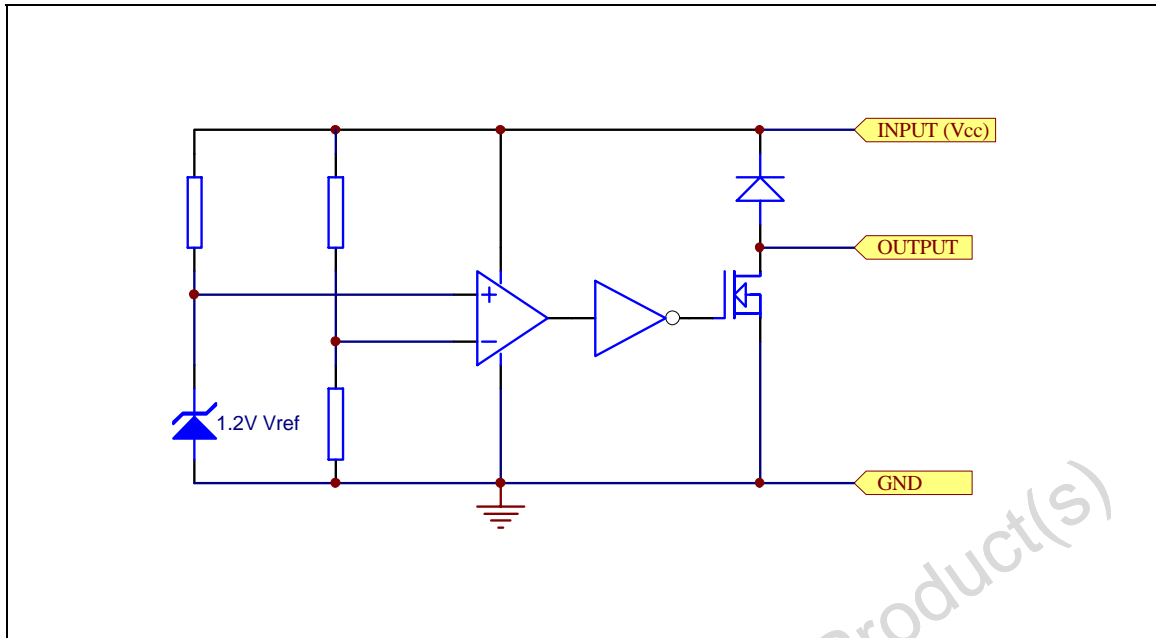

TIMING DIAGRAM

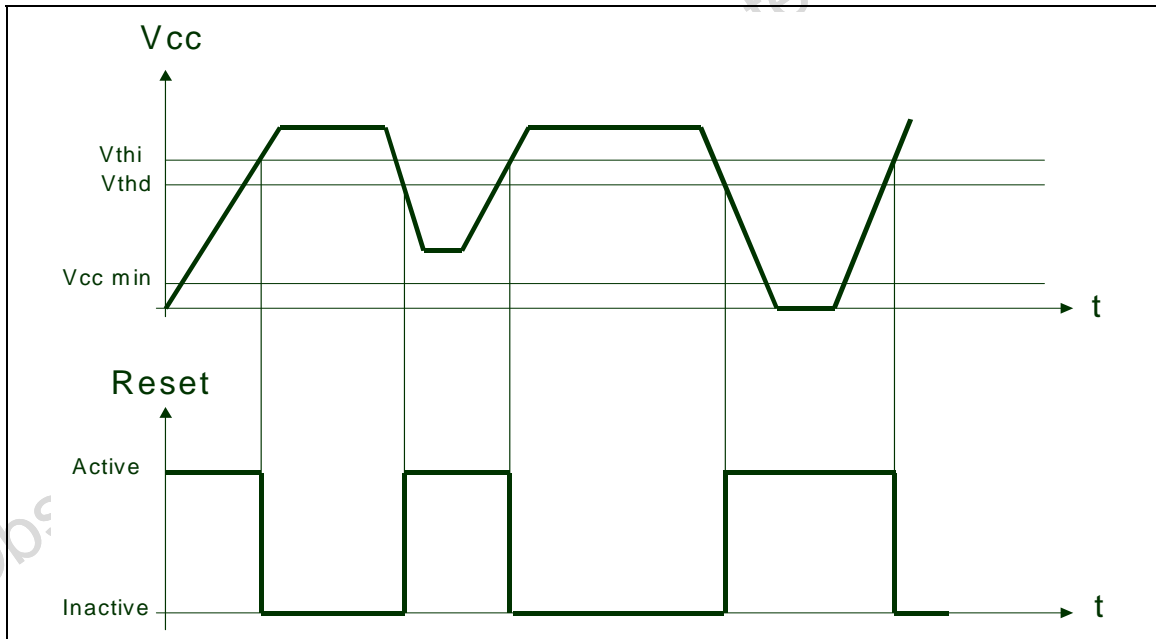

V_{th} vs Temperature while V_{CC} increasing

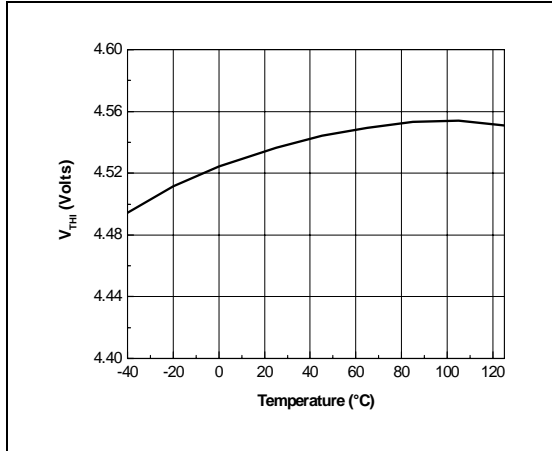

V_{th} vs Temperature while V_{CC} decreasing

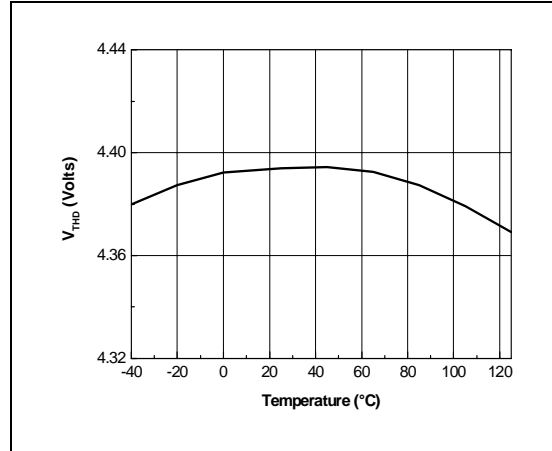

Hysteresis vs Temperature

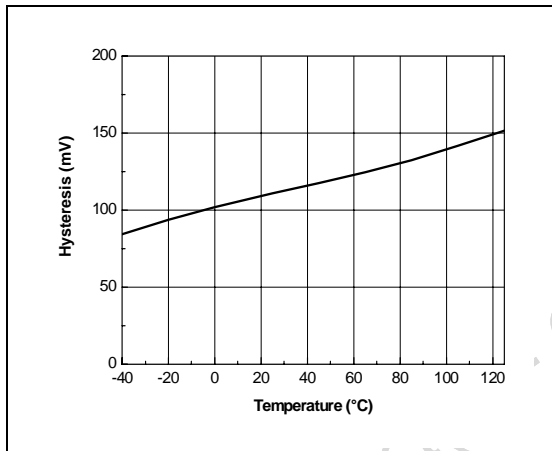

I_{CC} vs Temperature

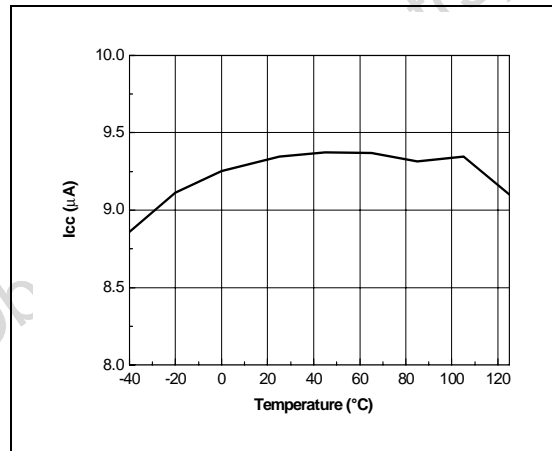

Reset Output Voltage vs Input Voltage

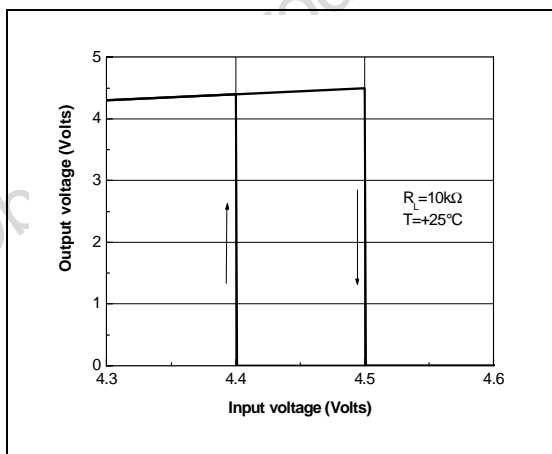

Voltage Output Low vs Sink Current

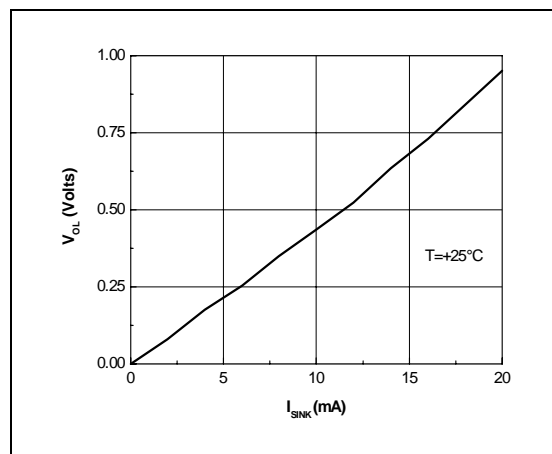

Reset Output Voltage vs Input Voltage

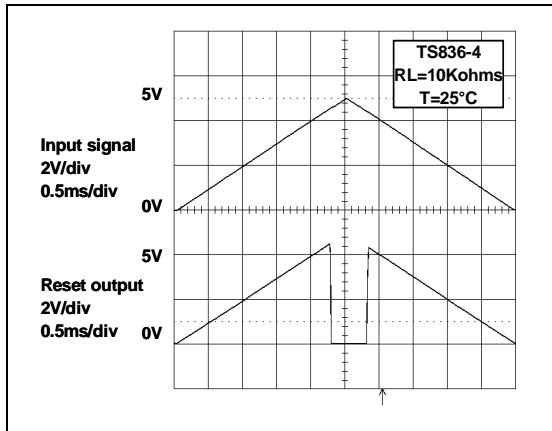

Supply Failing down: Reset Delay Time

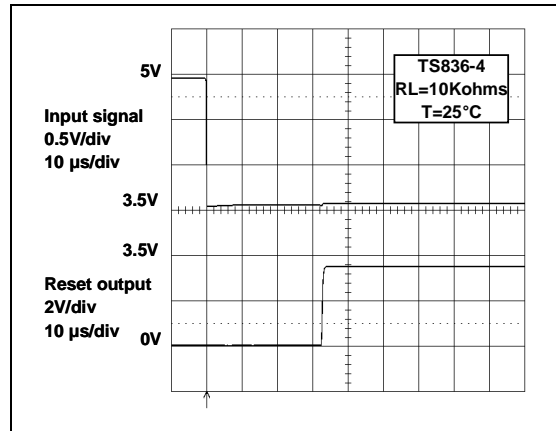

Supply Failing Down: Extended Reset Delay Time with an Additional Capacitor

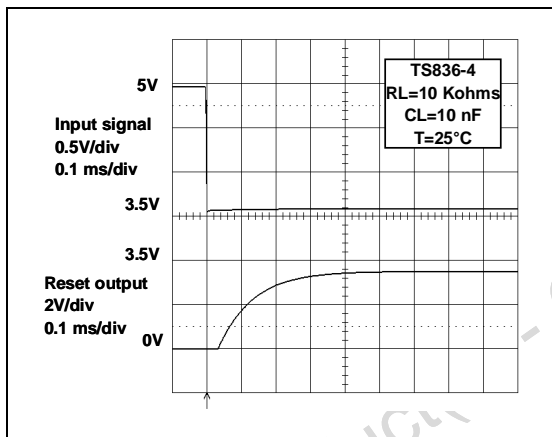

Supply Rising up: Output Delay Time

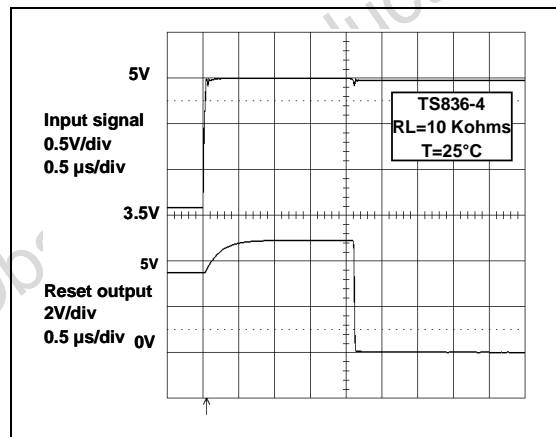

Reset Output Voltage vs Input Voltage (example)

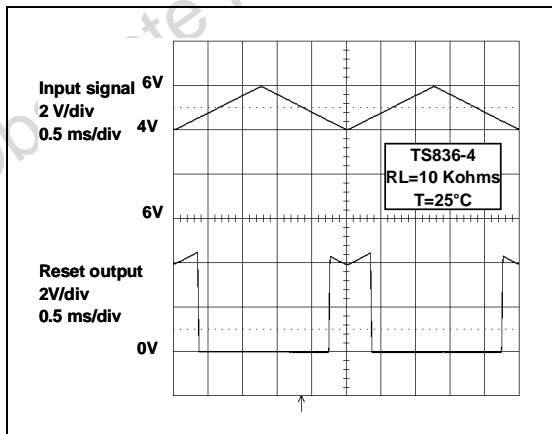

Reset Output Voltage vs Input Voltage (example)

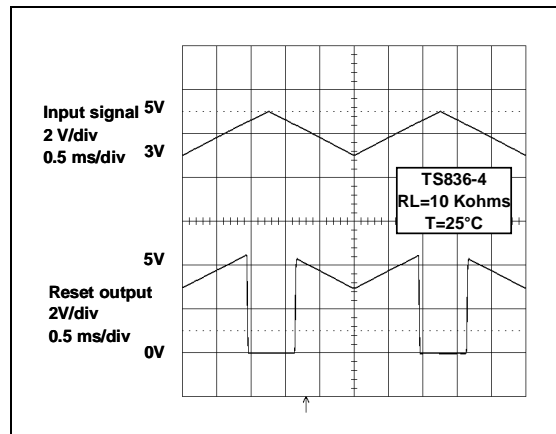

TS836

Basic configuration

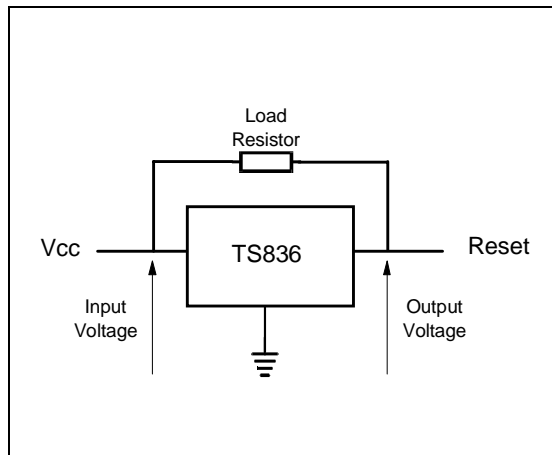

Configuration with an additional Capacitive Load

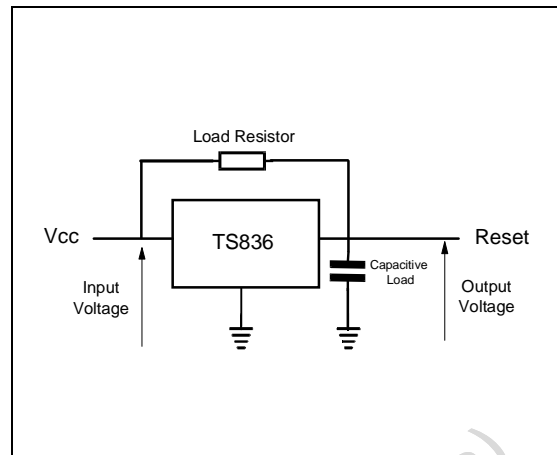

Obsolete Product(s) - Obsolete Product(s)

PACKAGE MECHANICAL DATA

SO-8 MECHANICAL DATA

DIM.	mm.			inch		
	MIN.	TYP.	MAX.	MIN.	TYP.	MAX.
A	1.35		1.75	0.053		0.069
A1	0.10		0.25	0.04		0.010
A2	1.10		1.65	0.043		0.065
B	0.33		0.51	0.013		0.020
C	0.19		0.25	0.007		0.010
D	4.80		5.00	0.189		0.197
E	3.80		4.00	0.150		0.157
e		1.27			0.050	
H	5.80		6.20	0.228		0.244
h	0.25		0.50	0.010		0.020
L	0.40		1.27	0.016		0.050
k	8° (max.)					
ddd			0.1			0.04

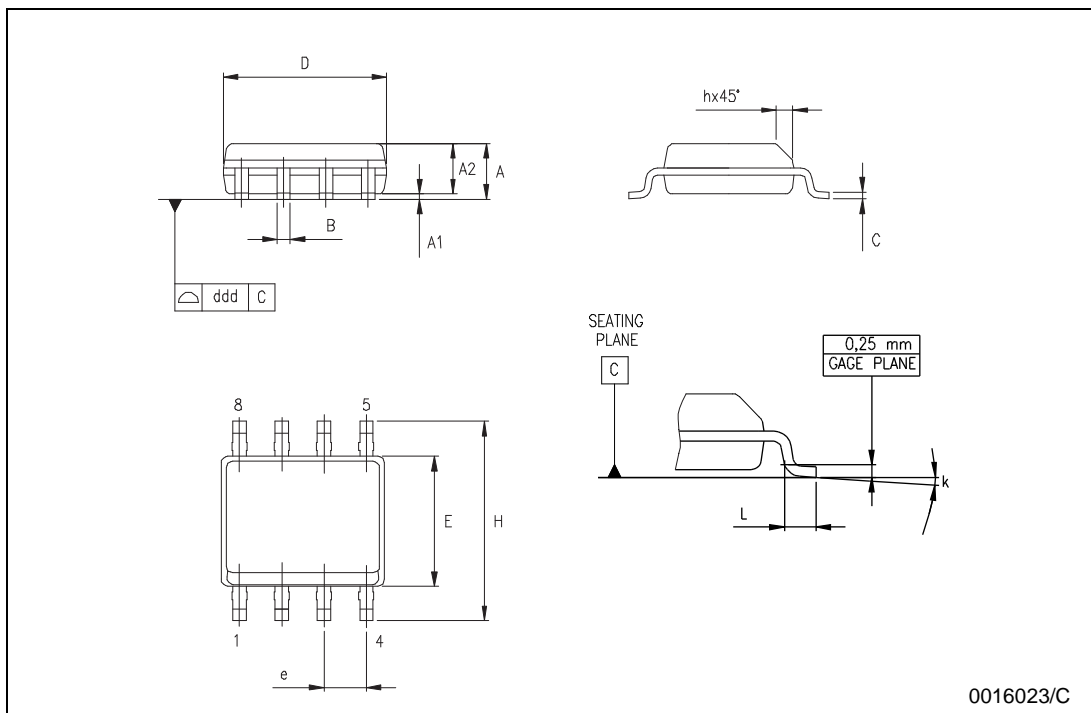

0016023/C

PACKAGE MECHANICAL DATA - TO92 TAPE AMMO PACK & TO92 TAPE & REEL

TO-92 MECHANICAL DATA

DIM.	mm.			inches		
	MIN.	TYP.	MAX.	MIN.	TYP.	MAX.
AL			5.0			0.197
A			5.0			0.197
T			4.0			0.157
d		0.45			0.018	
l1	2.5			0.098		
P	11.7	12.7	13.7	0.461	0.500	0.539
PO	12.4	12.7	13	0.488	0.500	0.512
P2	5.95	6.35	6.75	0.234	0.250	0.266
F1/F2	2.4	2.5	2.8	0.094	0.098	0.110
h	-1	0	1	-0.039	0	0.039
P	-1	0	1	-0.039	0	0.039
W	17.5	18.0	19.0	0.689	0.709	0.748
W0	5.7	6	6.3	0.224	0.236	0.248
W1	8.5	9	9.75	0.335	0.354	0.384
W2			0.5			0.020
H			20			0.787
H0	15.5	16	16.5	0.610	0.630	0.650
H1			25			0.984
DO	3.8	4.0	4.2	0.150	0.157	0.165
L1			11			0.433

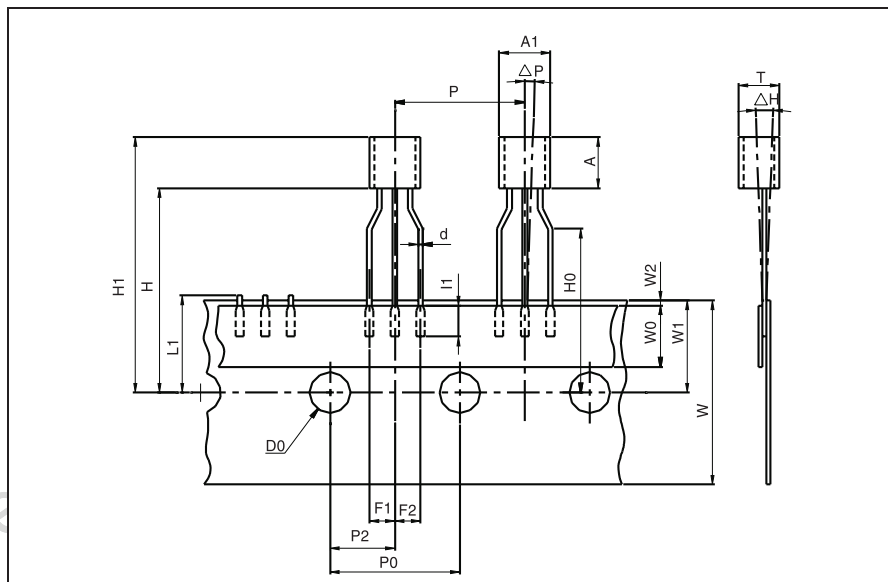

Packing information are available at: <http://www.st.com/stonline/prodpres/packages/stdlin.htm>

PACKAGE MECHANICAL DATA - TO92 BULK

TO-92 MECHANICA DATA						
DIM.	mm.			mils		
	MIN.	TYP	MAX.	MIN.	TYP.	MAX.
A	4.32		4.95	170.1		194.9
b	0.36		0.51	14.2		20.1
D	4.45		4.95	175.2		194.9
E	3.30		3.94	129.9		155.1
e	2.41		2.67	94.9		105.1
e1	1.14		1.40	44.9		55.1
L	12.7		15.49	500.0		609.8
R	2.16		2.41	85.0		94.9
S1	0.92		1.52	36.2		59.8
W	0.41		0.56	16.1		22.0

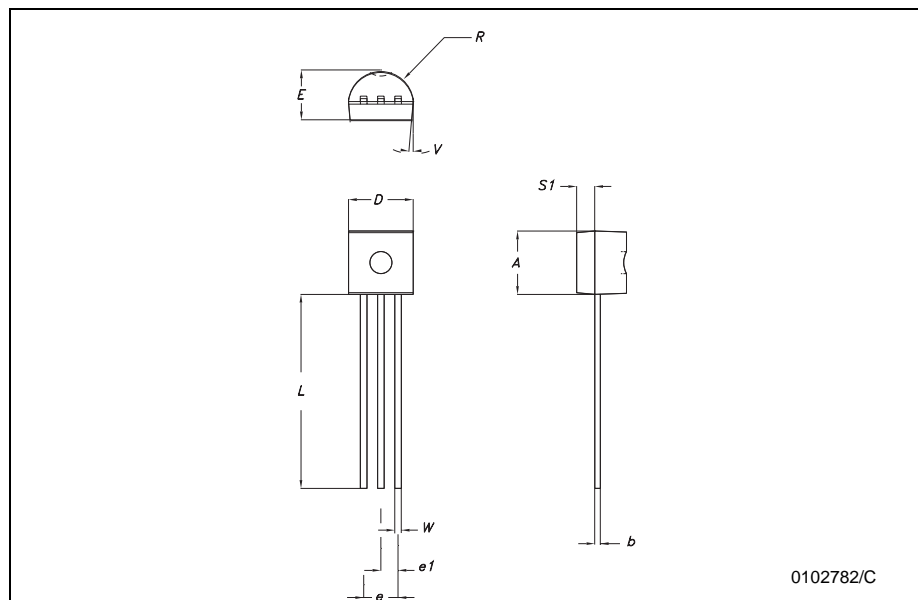

Packing information are available at: <http://www.st.com/stonline/prodpres/packages/stdlin.htm>

PACKAGE MECHANICAL DATA

TSSOP8 MECHANICAL DATA						
DIM.	mm.			inch		
	MIN.	TYP.	MAX.	MIN.	TYP.	MAX.
A			1.2			0.047
A1	0.05		0.15	0.002		0.006
A2	0.80	1.00	1.05	0.031	0.039	0.041
b	0.19		0.30	0.007		0.012
c	0.09		0.20	0.004		0.008
D	2.90	3.00	3.10	0.114	0.118	0.122
E	6.20	6.40	6.60	0.244	0.252	0.260
E1	4.30	4.40	4.50	0.169	0.173	0.177
e		0.65			0.0256	
K	0°		8°	0°		8°
L	0.45	0.60	0.75	0.018	0.024	0.030
L1		1			0.039	

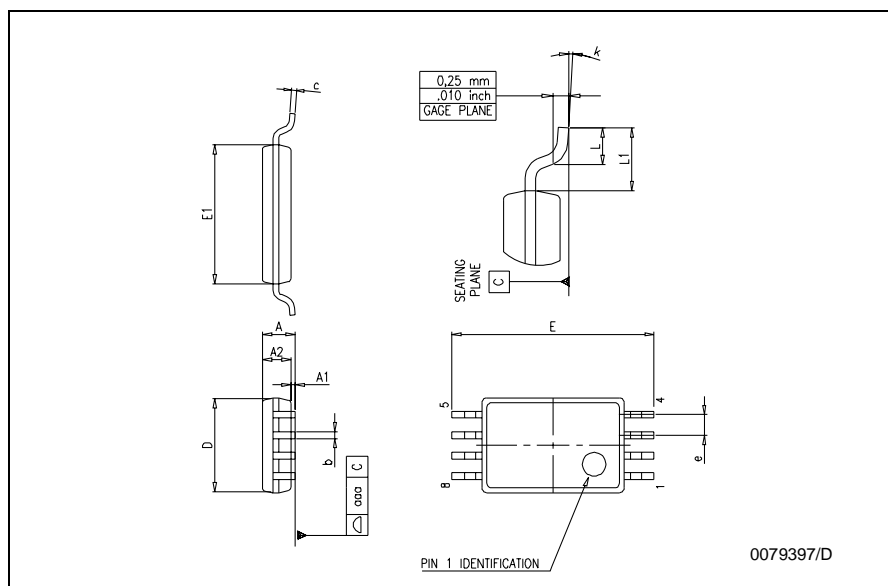

Information furnished is believed to be accurate and reliable. However, STMicroelectronics assumes no responsibility for the consequences of use of such information nor for any infringement of patents or other rights of third parties which may result from its use. No license is granted by implication or otherwise under any patent or patent rights of STMicroelectronics. Specifications mentioned in this publication are subject to change without notice. This publication supersedes and replaces all information previously supplied. STMicroelectronics products are not authorized for use as critical components in life support devices or systems without express written approval of STMicroelectronics.

© The ST logo is a registered trademark of STMicroelectronics

© 2003 STMicroelectronics - Printed in Italy - All Rights Reserved
 STMicroelectronics GROUP OF COMPANIES

Australia - Brazil - China - Finland - France - Germany - Hong Kong - India - Italy - Japan - Malaysia - Malta - Morocco
 Singapore - Spain - Sweden - Switzerland - United Kingdom

© <http://www.st.com>

