



3-Pin Microprocessor Power Supply Supervisors

FEATURES

- Precision monitoring of +3.3 V (-5%, -10%), 5 V (-10% Power Supplies)
- Active low reset output
- Reset valid down to $V_{CC} = 1.0$ V
- 6 μ A power supply current
- Power supply transient immunity
- Industrial temperature range: -40°C to +85°C
- RoHS-compliant SOT-23 package

APPLICATIONS

- Computers
- Servers
- Laptops
- Cable modems
- Wireless communications
- Embedded control systems
- White goods
- Power meters
- Intelligent instruments
- PDAs and handheld equipment

DESCRIPTION

The CAT853, CAT863, CAT859, and CAT869 are supervisory circuits that monitor power supplies in digital systems.

These devices generate a reset signal, which is asserted while the power supply voltage is below a preset threshold level and for at least 140 ms after the power supply level has risen above that level. Industry standard threshold levels are offered to support +3.3 V or 5.0 V systems.

The CAT859 and CAT869 feature a $\overline{\text{RESET}}$ push-pull output (active low) for the two pinout options.

The CAT853 and CAT863 feature an open drain $\overline{\text{RESET}}$ output (active low). Both require a pull-up resistor on the $\overline{\text{RESET}}$ output.

Fast transients on the power supply are ignored and the output is guaranteed to be in the correct state at V_{CC} levels as low as 1.0 V.

For Ordering Information details, see page 9.

PIN CONFIGURATION

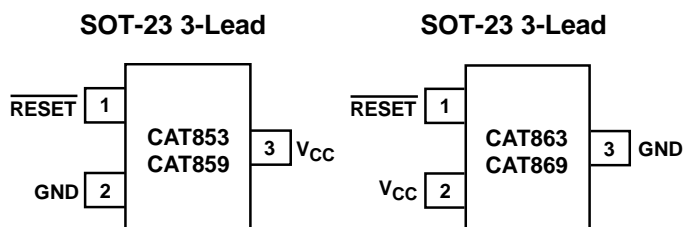

THRESHOLD SUFFIX SELECTOR

Nominal Threshold Voltage	Threshold Suffix Designation
4.38 V	M
4.20 V	F
3.08 V	T
2.93 V	S
2.4 V	C

PIN DESCRIPTION

Pin Name	Function
$\overline{\text{RESET}}$	Active low reset. $\overline{\text{RESET}}$ is asserted if V_{CC} falls below the reset threshold and remains low for at least 140 ms after V_{CC} rises above the reset threshold
GND	Ground
V_{CC}	Power supply voltage that is monitored

BLOCK DIAGRAMS

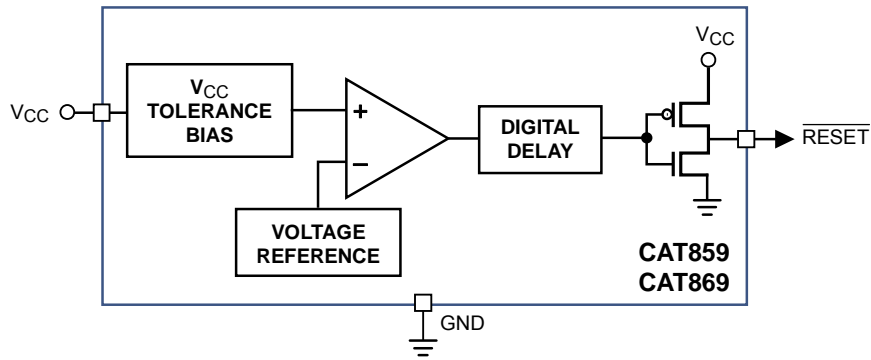
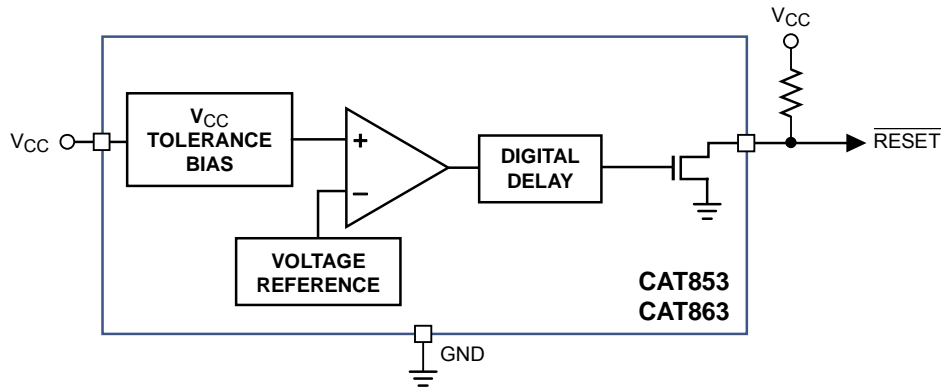

ABSOLUTE MAXIMUM RATINGS⁽¹⁾

Parameters	Ratings	Units
Any pin with respect to ground	-0.3 to +6.0	V
Input Current, V_{CC}	20	mA
Output Current, $\overline{\text{RESET}}$	20	mA
Rate of Rise, V_{CC}	100	V/ μ s
Continuous Power Dissipation Derate 4mW/ $^{\circ}$ C above 70 $^{\circ}$ C (SOT23)	320	mW
Operating Temperature Range	-40 to +85	$^{\circ}$ C
Storage Temperature Range	-65 to +105	$^{\circ}$ C
Lead Soldering Temperature (10 sec)	300	$^{\circ}$ C

ELECTRICAL CHARACTERISTICS

V_{CC} = Full range, T_A = -40 $^{\circ}$ C to +85 $^{\circ}$ C unless otherwise noted. Typical values at T_A = +25 $^{\circ}$ C and V_{CC} = 3.3 V for the C, S, T versions, V_{CC} = 5 V for the M version.

Symbol	Parameter	Conditions	Min	Typ ⁽²⁾	Max	Units	
	V_{CC} Range	T_A = 0 $^{\circ}$ C to +70 $^{\circ}$ C	1.0		5.5	V	
		T_A = -40 $^{\circ}$ C to +85 $^{\circ}$ C	1.2		5.5		
I_{CC}	Supply Current	T_A = -40 $^{\circ}$ C to +85 $^{\circ}$ C V_{CC} < 3.6 V, C, S, T		6	15	μ A	
V_{TH}	Reset Threshold Voltage	M Threshold	T_A = +25 $^{\circ}$ C	4.31	4.38	4.45	V
			T_A = -40 $^{\circ}$ C to +85 $^{\circ}$ C	4.25		4.50	
		F Threshold	T_A = +25 $^{\circ}$ C	4.14	4.20	4.26	
			T_A = -40 $^{\circ}$ C to +85 $^{\circ}$ C	4.08		4.31	
		T Threshold	T_A = +25 $^{\circ}$ C	3.04	3.08	3.11	
			T_A = -40 $^{\circ}$ C to +85 $^{\circ}$ C	3.00		3.15	
		S Threshold	T_A = +25 $^{\circ}$ C	2.89	2.93	2.96	
			T_A = -40 $^{\circ}$ C to +85 $^{\circ}$ C	2.85		3.00	
		C Threshold	T_A = +25 $^{\circ}$ C	2.35	2.40	2.45	
			T_A = -40 $^{\circ}$ C to +85 $^{\circ}$ C	2.30		2.50	
	Reset Threshold Tempco			30		ppm/ $^{\circ}$ C	
	V_{CC} to Reset Delay	$V_{CC} = V_{TH}$ to ($V_{TH} - 100$ mV)		20		μ s	
	Reset Active Timeout Period	T_A = -40 $^{\circ}$ C to +85 $^{\circ}$ C	140	240	460	ms	
V_{OL}	$\overline{\text{RESET}}$ Output Voltage Low	$V_{CC} = V_{TH}$ min, $I_{SINK} = 1.2$ mA			0.4	V	
		$V_{CC} > 1.0$ V, $I_{SINK} = 50$ μ A			0.3		
V_{OH}	$\overline{\text{RESET}}$ Output Voltage High	$V_{CC} = V_{TH}$ max, $I_{SOURCE} = -500$ μ A (for CAT859/869 only)	0.8 V_{CC}			V	

Notes:

- Stresses above those listed under "Absolute Maximum Ratings" may cause permanent damage to the device. These are stress ratings only, and functional operation of the device at these or any other conditions outside of those listed in the operational sections of this specification is not implied. Exposure to any absolute maximum rating for extended periods may affect device performance and reliability.
- Production testing done at T_A = +25 $^{\circ}$ C; limits over temperature guaranteed by design only.

TYPICAL ELECTRICAL OPERATING CHARACTERISTICS

V_{CC} = Full range, T_A = -40°C to +85°C unless otherwise noted. Typical values at T_A = +25°C and V_{CC} = 3.3 V for the C, S, T versions, V_{CC} = 5 V for the M version.

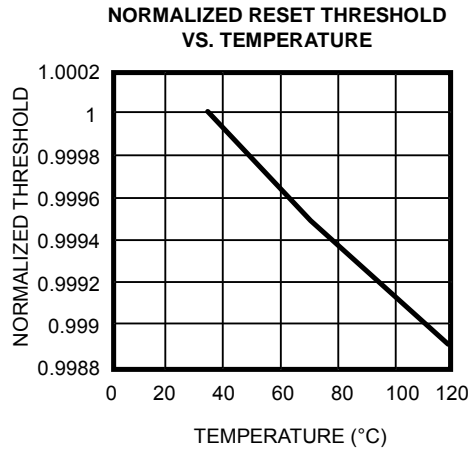
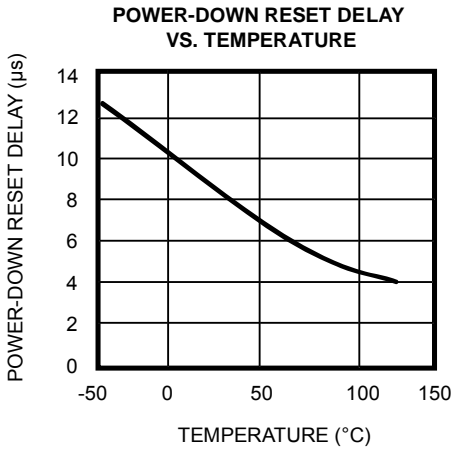
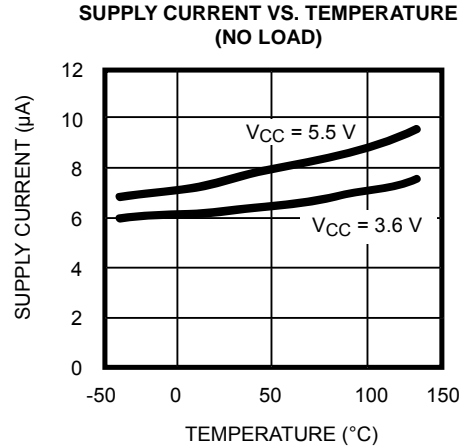
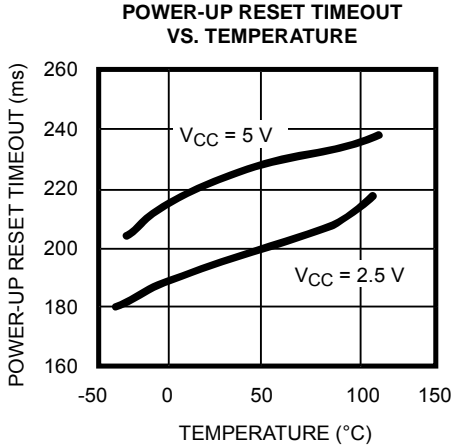

DETAILED DESCRIPTION

RESET TIMING

The reset signal is asserted low for the CAT853, CAT863, CAT859, and CAT869 when the power supply voltage falls below the threshold trip voltage and remains asserted for at least 140 ms after the power supply voltage has risen above the threshold.

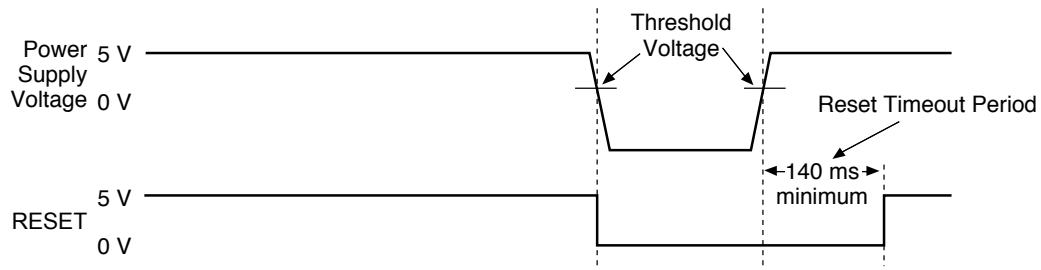

Figure 1. Reset Timing Diagram

V_{CC} TRANSIENT RESPONSE

The CAT853, CAT863, CAT859, and CAT869 protect μ Ps against brownout failure. Short duration transients of 4 μ s or less and 100 mV amplitude typically do not cause a false RESET.

Figure 2 shows the maximum pulse duration of negative-going V_{CC} transients that do not cause a

reset condition. As the amplitude of the transient goes further below the threshold (increasing $V_{TH} - V_{CC}$), the maximum pulse duration decreases. In this test, the V_{CC} starts from an initial voltage of 0.5 V above the threshold and drops below it by the amplitude of the overdrive voltage ($V_{TH} - V_{CC}$).

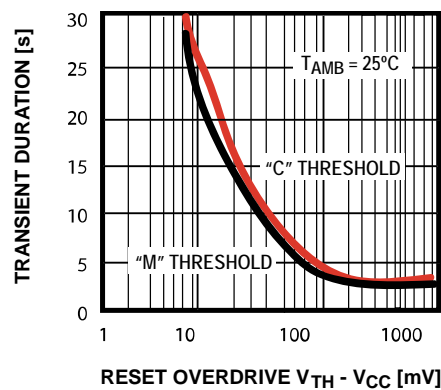

Figure 2. Maximum Transient Duration Without Causing a Reset Pulse vs. Reset Comparator Overdrive

VALID RESET WITH V_{CC} UNDER 1.0 V

To ensure that the CAT859 and CAT869 $\overline{\text{RESET}}$ pin is in a known state when V_{CC} is under 1.0 V, a $> 10 \text{ k}\Omega$ pull-down resistor between $\overline{\text{RESET}}$ pin and GND is recommended.

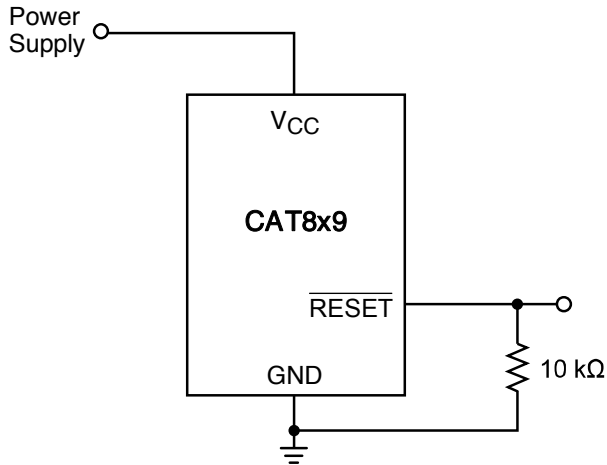

Figure 3. $\overline{\text{RESET}}$ Valid with V_{CC} Under 1.0 V

BI-DIRECTIONAL RESET PIN INTERFACING

The CAT859 and CAT869 can interface with $\mu\text{P}/\mu\text{C}$ bi-directional reset pins by connecting a $4.7 \text{ k}\Omega$ resistor in series with the CAT859 and CAT869 reset output and the $\mu\text{P}/\mu\text{C}$ bi-directional reset pin.

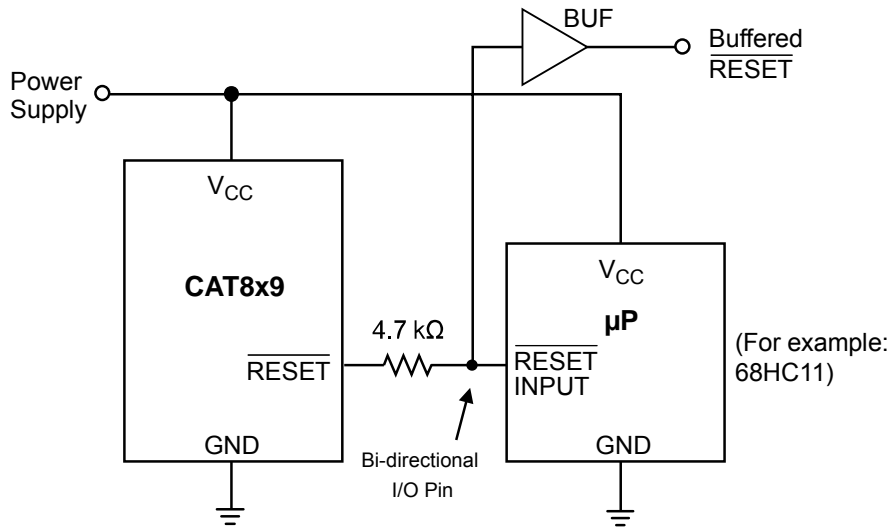

Figure 4. Bi-directional Reset Pin Interfacing

CAT853 AND CAT863 OPEN-DRAIN RESET APPLICATION

The CAT853 and CAT863 features an open-drain RESET output and therefore need a pull-up resistor on the output for proper operation, as shown on Figure 5. An advantage of the open-drain output includes the ability to “wire AND” several outputs together to form an inexpensive logic circuit. It is also possible to have the pull-up resistor connected to a different supply which can be higher than the CAT8x3 V_{CC} pin. The value of the pull-up resistor is not critical in most applications, typical values being between 5 k Ω and 10 k Ω .

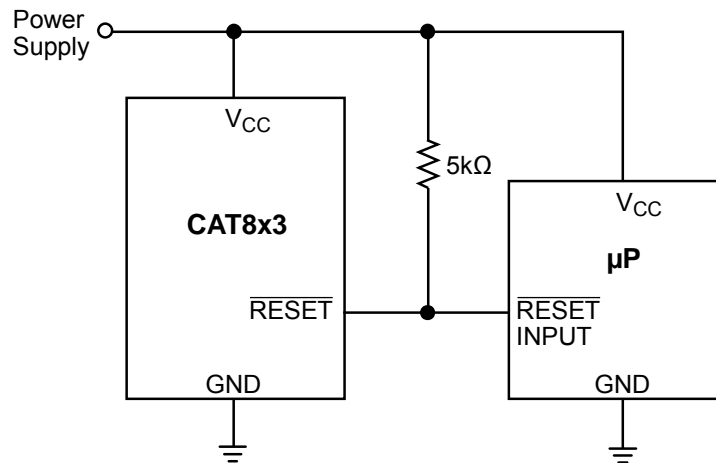
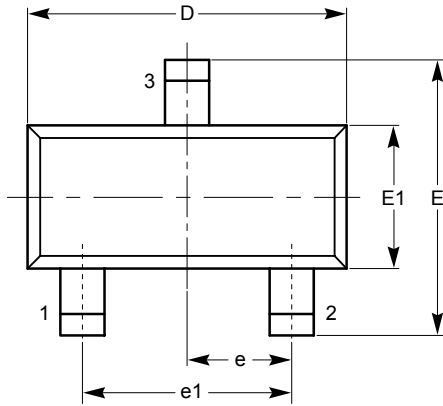

Figure 5. Typical CAT8x3 Open-Drain Circuit Configuration

PACKAGE OUTLINE DRAWING

SOT-23 3-LEAD (TB) ⁽¹⁾⁽²⁾



TOP VIEW

SYMBOL	MIN	NOM	MAX
A	0.89		1.12
A1	0.013		0.10
b	0.37		0.50
c	0.085		0.18
D	2.80		3.04
E	2.10		2.64
E1	1.20		1.40
e	0.95 BSC		
e1	1.90 BSC		
L	0.400 REF		
L1	0.540 REF		
θ	0°		8°

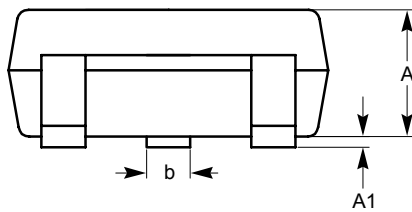

SIDE VIEW

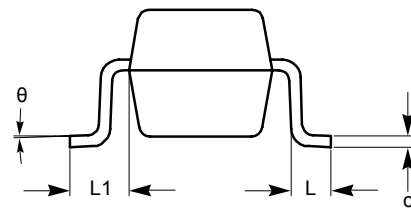

END VIEW

Notes:

- (1) All dimensions in millimeters. Angles in degrees.
- (2) Complies with JEDEC standard TO-236.

EXAMPLE OF ORDERING INFORMATION ⁽¹⁾ ⁽²⁾ ⁽³⁾

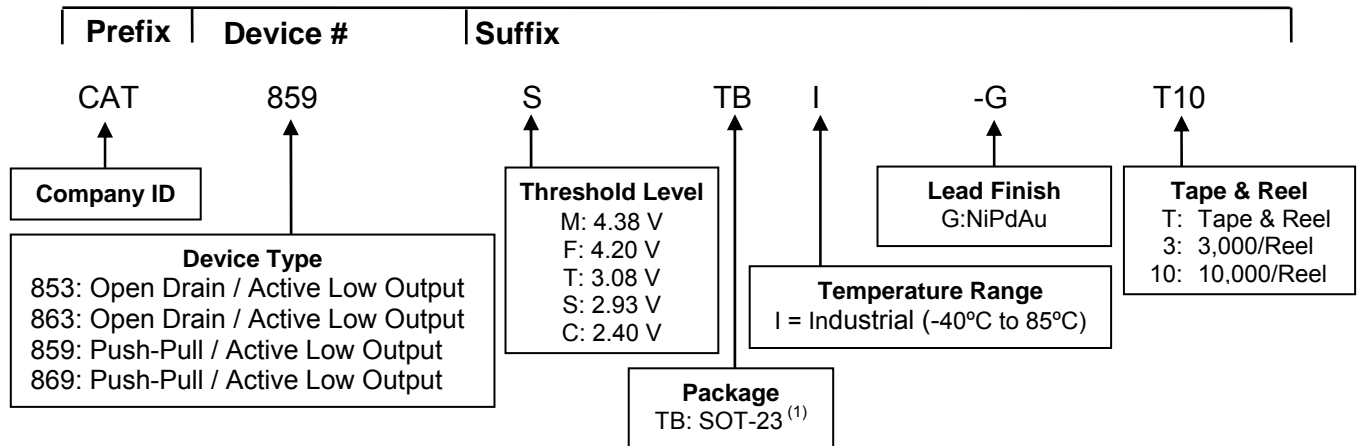

TOP MARKING

Part and Threshold	SOT-23 RoHS NiPdAu Finish ⁽⁴⁾ ⁽⁵⁾
CAT859C	RSYM
CAT859T	
CAT859S	
CAT859F	
CAT859M	
CAT869T	RTYM
CAT869S	
CAT869M	

Part and Threshold	SOT-23 RoHS NiPdAu Finish ⁽⁴⁾ ⁽⁵⁾
CAT853C	RUYM
CAT853T	
CAT853S	
CAT853F	
CAT853M	
CAT863T	RVYM
CAT863S	
CAT863M	

ORDERING PART NUMBER ⁽⁶⁾

CAT859CTBI-G
CAT859TTBI-G
CAT859STBI-G
CAT859FTBI-G
CAT859MTBI-G

CAT869TTBI-G
CAT869STBI-G
CAT869MTBI-G

CAT853CTBI-G
CAT853TTBI-G
CAT853STBI-G
CAT853FTBI-G
CAT853MTBI-G

CAT863TTBI-G
CAT863STBI-G
CAT863MTBI-G

Notes:

- (1) All packages are RoHS-compliant (Lead-free, Halogen-free).
- (2) The device used in the example above is a CAT859STBI-GT10 (Push-Pull / Active Low Output, trip level of 2.85 V to 3.00 V NiPdAu, Tape and Reel).
- (3) For additional package and temperature options, please contact your nearest ON Semiconductor Sales office.
- (4) The "YM" in the SOT-23 package marking indicates the Year and Month of production.
- (5) All NiPdAu devices will be marked to indicate product type. Threshold and full part numbers will be provided on box and reel labels as well as all Shipping documents.
- (6) For special threshold and package options, contact factory.

REVISION HISTORY

Date	Rev.	Description
11-Oct-06	A	Initial Issue CAT859, CAT869
04-May-07	B	Added CAT853, CAT863 Update Example of Ordering Information Update Top Marking Update Ordering Part Number
17-Jan-07	C	Add Threshold Level - C: 2.40 V Update Package Outline Drawing Add MD- to document number
30-Jan-08	D	Added Block Diagrams
05-Nov-08	E	Change logo and fine print to ON Semiconductor
04-Mar-09	F	Convert to MS Word format
08-Apr-09	G	Add Nominal Threshold Voltage 4.20 "F"

ON Semiconductor and  are registered trademarks of Semiconductor Components Industries, LLC (SCILLC). SCILLC reserves the right to make changes without further notice to any products herein. SCILLC makes no warranty, representation or guarantee regarding the suitability of its products for any particular purpose, nor does SCILLC assume any liability arising out of the application or use of any product or circuit, and specifically disclaims any and all liability, including without limitation special, consequential or incidental damages. "Typical" parameters which may be provided in SCILLC data sheets and/or specifications can and do vary in different applications and actual performance may vary over time. All operating parameters, including "Typicals" must be validated for each customer application by customer's technical experts. SCILLC does not convey any license under its patent rights nor the rights of others. SCILLC products are not designed, intended, or authorized for use as components in systems intended for surgical implant into the body, or other applications intended to support or sustain life, or for any other application in which the failure of the SCILLC product could create a situation where personal injury or death may occur. Should Buyer purchase or use SCILLC products for any such unintended or unauthorized application, Buyer shall indemnify and hold SCILLC and its officers, employees, subsidiaries, affiliates, and distributors harmless against all claims, costs, damages, and expenses, and reasonable attorney fees arising out of, directly or indirectly, any claim of personal injury or death associated with such unintended or unauthorized use, even if such claim alleges that SCILLC was negligent regarding the design or manufacture of the part. SCILLC is an Equal Opportunity/Affirmative Action Employer. This literature is subject to all applicable copyright laws and is not for resale in any manner.

PUBLICATION ORDERING INFORMATION

LITERATURE FULFILLMENT:

Literature Distribution Center for ON Semiconductor
P.O. Box 5163, Denver, Colorado 80217 USA
Phone: 303-675-2175 or 800-344-3860 Toll Free USA/Canada
Fax: 303-675-2176 or 800-344-3867 Toll Free USA/Canada
Email: orderlit@onsemi.com

N. American Technical Support: 800-282-9855 Toll Free
USA/Canada
Europe, Middle East and Africa Technical Support:
Phone: 421 33 790 2910
Japan Customer Focus Center:
Phone: 81-3-5773-3850

ON Semiconductor Website: www.onsemi.com

Order Literature: <http://www.onsemi.com/orderlit>

For additional information, please contact your local Sales Representative