

High-Voltage, Low-Current Voltage Monitors in SOT Packages

General Description

The MAX6457–MAX6460 high supply voltage, low-power voltage monitors operate over a 4V to 28V supply voltage range. Each device includes a precision bandgap reference, one or two low-offset voltage comparators, internal threshold hysteresis, power-good or reset timeout options, and one or two high-voltage open-drain outputs. Two external resistors (three for window detection) set the trip threshold voltages.

The MAX6457 is a single voltage monitor for undervoltage or overvoltage detection. A logic-based clear input either latches the output for overvoltage applications or allows the device to operate in transparent mode. The MAX6458 includes two comparators (one overvoltage and one undervoltage) for window detection and a single output to indicate if the monitored input is within an adjustable voltage window. The MAX6459 includes dual overvoltage/undervoltage comparators with two independent comparator outputs. Use the MAX6459 as a window comparator with separate undervoltage and overvoltage outputs or as two independent, single voltage monitors. The MAX6460 includes a single comparator and an internal reference, and can also accept an external reference. The inverting and noninverting inputs of the comparator are externally accessible to support positive or negative voltage monitors and to configure the device for active-high or active-low output logic.

The MAX6457/MAX6458 offer fixed timing options as a voltage detector with a 50 μ s typical delay or as a reset circuit with a 90ms minimum reset timeout delay. The monitored input must be above the adjusted trip threshold (or within the adjusted voltage window for the MAX6458) for the selected timeout period before the output changes state. The MAX6459/MAX6460 offer only a fixed 50 μ s timeout period. Internal threshold hysteresis options (0.5%, 5%, and 8.3% for the MAX6457/MAX6458/MAX6459, and 0.5% for the MAX6460) reduce output chatter in noise-sensitive applications. Each device is available in a small SOT23 package and specified over the extended temperature range of -40°C to +125°C.

Applications

Undervoltage Monitoring/Shutdown
 Overvoltage Monitoring/Protection
 Window Voltage Detection Circuitry
 Multicell Battery-Stack Powered Equipment
 Notebooks, eBooks
 Automotive
 Industrial
 Telecom
 Networking

Features

- ◆ Wide Supply Voltage Range, 4V to 28V
- ◆ Internal 2.25V \pm 2.5% Reference
- ◆ Low Current (3.5 μ A, typ at 12V)
- ◆ Open-Drain n-Channel Output (28V Compliant)
- ◆ Internal Threshold Hysteresis Options (0.5%, 5%, 8.3%)
- ◆ Two IN-to-OUT Timeout Period Options (50 μ s, 150ms)
- ◆ Internal Undervoltage Lockout
- ◆ Immune to Short Voltage Transients
- ◆ Small SOT23 Packages
- ◆ Few External Components
- ◆ Fully Specified from -40°C to +125°C

Ordering Information

PART	TEMP RANGE	PIN-PACKAGE
MAX6457UKD__-T	-40°C to +125°C	5 SOT23
MAX6458UKD__-T	-40°C to +125°C	5 SOT23
MAX6459UT_-T	-40°C to +125°C	6 SOT23
MAX6460UT-T	-40°C to +125°C	6 SOT23

Note: The MAX6457/MAX6458/MAX6459 are available with factory-trimmed internal hysteresis options. The MAX6457 and MAX6458 offer two fixed timing options. Select the desired hysteresis and timing options using Table 1 or the Selector Guide at the end of the data sheet, and enter the corresponding letters and numbers in the part number by replacing “_” or “-”. These devices are offered in tape-and-reel only and must be ordered in 2500-piece increments.

Devices are available in both leaded and lead(Pb)-free/RoHS-compliant packaging. Specify lead(Pb)-free by replacing “-T” with “+T” when ordering.

Pin Configurations appear at end of data sheet.

Typical Operating Circuit

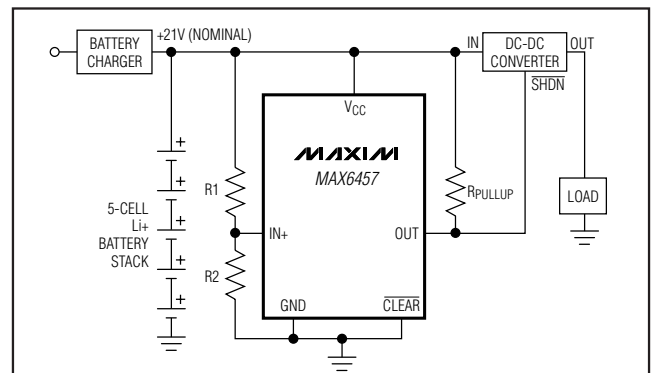

High-Voltage, Low-Current Voltage Monitors in SOT Packages

ABSOLUTE MAXIMUM RATINGS

V_{CC} , OUT, OUTA, OUTB, $\overline{\text{CLEAR}}$ to GND -0.3V to +30.0V
 IN+, IN- to GND -0.3V to (V_{CC} + 0.3V)
 REF to GND -0.3V to the lower of +6V and (V_{CC} + 0.3V)
 Input Currents (V_{CC} , IN+, IN-) 20mA
 Sink Current (OUT, OUTA, OUTB) 20mA
 Continuous Power Dissipation ($T_A = +70^\circ\text{C}$)
 5-Pin SOT23 (derate 7.1 mW/ $^\circ\text{C}$ above +70 $^\circ\text{C}$) 571mW
 6-Pin SOT23 (derate 8.7 mW/ $^\circ\text{C}$ above +70 $^\circ\text{C}$) 696mW

Junction Temperature +150 $^\circ\text{C}$
 Operating Temperature Range -40 $^\circ\text{C}$ to +125 $^\circ\text{C}$
 Storage Temperature Range -65 $^\circ\text{C}$ to +150 $^\circ\text{C}$
 Lead Temperature (soldering, 10s) +300 $^\circ\text{C}$

Stresses beyond those listed under "Absolute Maximum Ratings" may cause permanent damage to the device. These are stress ratings only, and functional operation of the device at these or any other conditions beyond those indicated in the operational sections of the specifications is not implied. Exposure to absolute maximum rating conditions for extended periods may affect device reliability.

ELECTRICAL CHARACTERISTICS

($V_{CC} = 4\text{V}$ to 28V, $T_A = -40^\circ\text{C}$ to +125 $^\circ\text{C}$, unless otherwise specified. Typical values are at $T_A = +25^\circ\text{C}$.) (Note 1)

PARAMETER	SYMBOL	CONDITIONS	MIN	TYP	MAX	UNITS		
Operating Voltage Range	V_{CC}	(Note 2)	4		28	V		
Supply Current	I_{CC}	$V_{CC} = 5\text{V}$, no load		2	5	μA		
		$V_{CC} = 12\text{V}$, no load		3.5	7.5			
		$V_{CC} = 24\text{V}$, no load		6.5	12.5			
Threshold Voltage	V_{TH+}	V_{IN} rising	$T_A = -40^\circ\text{C}$ to +85 $^\circ\text{C}$, $V_{CC} \geq 4\text{V}$	1.195	1.228	1.255	V	
			$T_A = +85^\circ\text{C}$ to +125 $^\circ\text{C}$, $V_{CC} \geq 4\text{V}$	1.170		1.255		
	V_{TH-}	V_{IN} falling	MAX645_U_D_A	$T_A = -40^\circ\text{C}$ to +85 $^\circ\text{C}$	1.180			1.255
				$T_A = +85^\circ\text{C}$ to +125 $^\circ\text{C}$	1.155			1.255
			MAX645_U_D_B	$T_A = -40^\circ\text{C}$ to +85 $^\circ\text{C}$	1.133			1.194
				$T_A = +85^\circ\text{C}$ to +125 $^\circ\text{C}$	1.111			1.194
	MAX645_U_D_C	$T_A = -40^\circ\text{C}$ to +85 $^\circ\text{C}$	1.093		1.151			
		$T_A = +85^\circ\text{C}$ to +125 $^\circ\text{C}$	1.071		1.151			
Threshold Voltage Hysteresis		MAX64_U_D_A		0.5		% V_{TH+}		
		MAX64_U_D_B		5				
		MAX64_U_D_C		8.3				
IN Operating Voltage Range	V_{IN}	(Note 2)	0		V_{CC}	V		
IN Leakage Current	I_{IN}	$V_{IN} = 1.25\text{V}$, $V_{CC} = +28\text{V}$	-55		+55	nA		
OUT Timeout Period	t_{TP}	MAX645_UKD0_ MAX6459UT_ MAX6460UT		50		μs		
		MAX6457 and MAX6458 only, D3 option	90	150	210	ms		
Startup Time		V_{CC} rising from GND to $V_{CC} \geq 4\text{V}$ in less than 1 μs (Note 3)		2		ms		
$\overline{\text{CLEAR}}$ Input Logic Voltage (MAX6457)	V_{IL}				0.4	V		
	V_{IH}		2					

High-Voltage, Low-Current Voltage Monitors in SOT Packages

MAX6457-MAX6460

ELECTRICAL CHARACTERISTICS (continued)

($V_{CC} = 4V$ to $28V$, $T_A = -40^{\circ}C$ to $+125^{\circ}C$, unless otherwise specified. Typical values are at $T_A = +25^{\circ}C$.) (Note 1)

PARAMETER	SYMBOL	CONDITIONS	MIN	TYP	MAX	UNITS
Output Voltage Low	VOL	$V_{CC} \geq 1.5V$, $I_{SINK} = 250\mu A$, OUT asserted, $T_A = -40^{\circ}C$ to $+85^{\circ}C$			0.4	V
		$V_{CC} \geq 4.0V$, $I_{SINK} = 1mA$, OUT asserted, $T_A = -40^{\circ}C$ to $+125^{\circ}C$			0.4	
Output Leakage Current	ILKG	$V_{CC} = 5V$, $V_{OUT} = 28V$ (Note 4)			500	nA
Output Short-Circuit Sink	ISC	OUT asserted, $OUT = V_{CC}$		10		mA
MAX6460						
Reference Short-Circuit Current		REF = GND		7		mA
Reference Output Voltage	VREF	$T_A = -40^{\circ}C$ to $+85^{\circ}C$	2.183	2.25	2.303	V
		$T_A = +85^{\circ}C$ to $+125^{\circ}C$	2.171	2.25	2.303	
Load Regulation		Sourcing: $0 \leq I_{REF} \leq 100\mu A$, sinking: $0 \leq I_{REF} \leq 300nA$		50		$\mu V/\mu A$
Input Offset Voltage	V _{OFFSET}		-4.5		+4.5	mV
Input Hysteresis				6		mV
Input Bias Current	I _{BIAS}	$V_{IN+} = 1.4V$, $V_{IN-} = 1V$	-25		+25	nA
Input Offset Current	I _{OFFSET}			2		pA
Common-Mode Voltage Range	CMVR		0		1.4	V
Common-Mode Rejection Ratio	CMRR			80		dB
Comparator Power-Supply Rejection Ratio	PSRR	$V_{IN+} = V_{IN-} = 1.4V$		80		dB

Note 1: Devices are production tested at $T_A = +25^{\circ}C$. Overtemperature limits are guaranteed by design.

Note 2: IN voltage monitoring requires that $V_{CC} \geq 4V$, but OUT remains asserted in the correct undervoltage lockout state for V_{CC} down to $1.5V$.

Note 3: Startup time is the time required for the internal regulator and reference to reach specified accuracy after the monitor is powered up from GND.

Note 4: The open-drain output can be pulled up to a voltage greater than V_{CC} but cannot exceed $+28V$.

High-Voltage, Low-Current Voltage Monitors in SOT Packages

Typical Operating Characteristics

(GND = 0, R_{PULLUP} = 10kΩ, and T_A = +25°C, unless otherwise noted.)

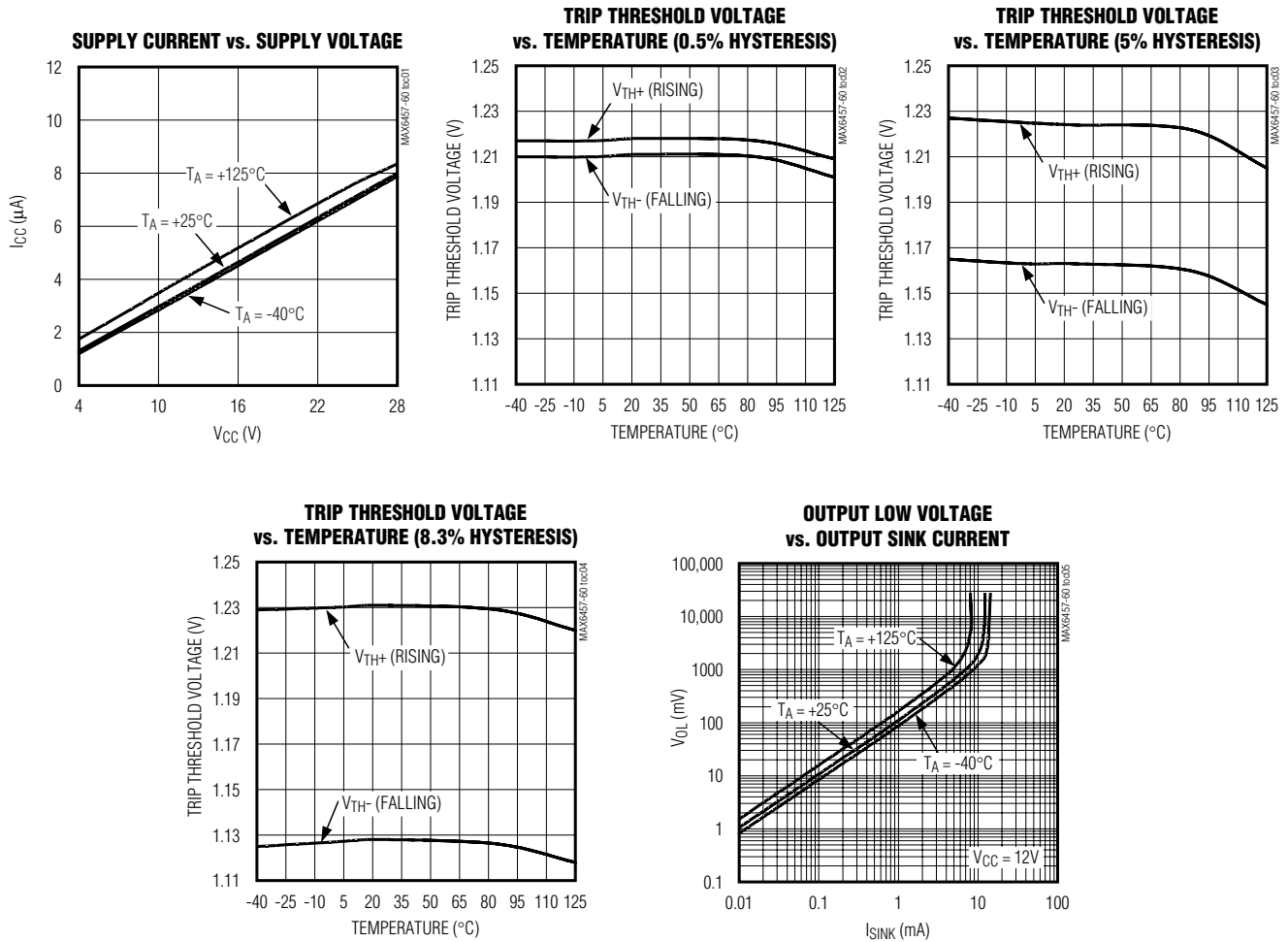

High-Voltage, Low-Current Voltage Monitors in SOT Packages

Typical Operating Characteristics (continued)

(GND = 0, R_{PULLUP} = 10kΩ, and T_A = +25°C, unless otherwise noted.)

MAX6457-MAX6460

OUTPUT SHORT-CIRCUIT SINK CURRENT vs. TEMPERATURE

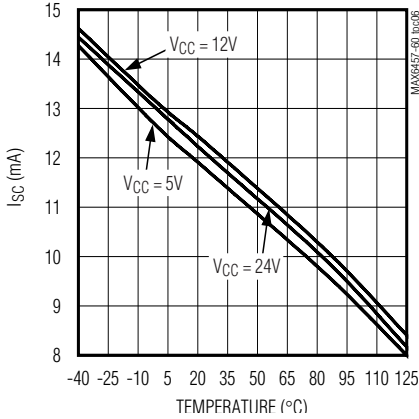

TIMEOUT PERIOD vs. TEMPERATURE

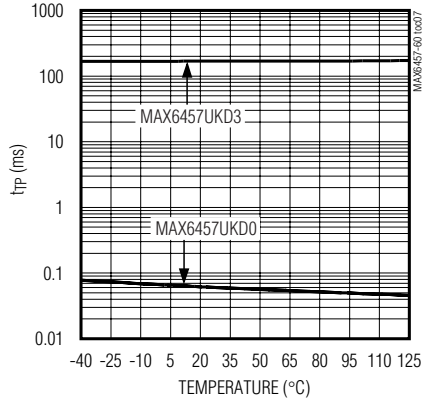

OUTPUT FALL TIME vs. SUPPLY VOLTAGE

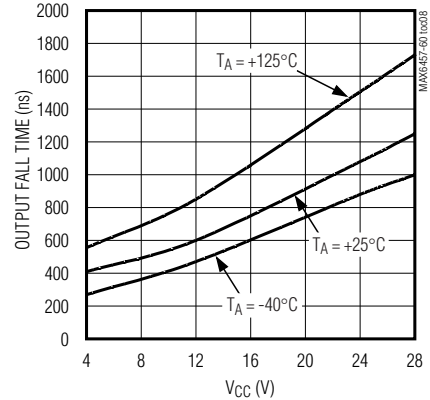

MAXIMUM TRANSIENT DURATION vs. INPUT OVERDRIVE

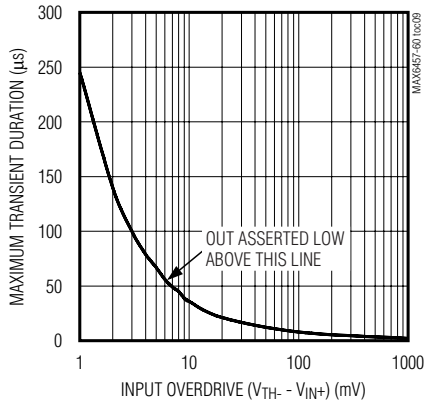

INPUT LEAKAGE CURRENT vs. TEMPERATURE

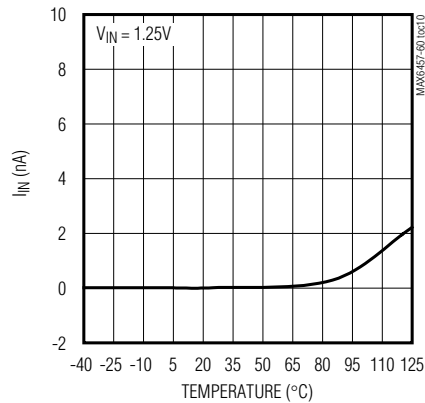

High-Voltage, Low-Current Voltage Monitors in SOT Packages

Pin Description

PIN				NAME	FUNCTION
MAX6457	MAX6458	MAX6459	MAX6460		
1	1	—	1	OUT	MAX6457: Open-Drain Monitor Output. OUT requires an external pullup resistor. OUT asserts low for V_{CC} between 1.5V and 4V. OUT asserts low when V_{IN+} drops below V_{TH-} and goes high after the timeout period (t_{TP}) when V_{IN+} exceeds V_{TH+} .
					MAX6458: Open-Drain Monitor Output. OUT requires an external pullup resistor. OUT asserts low for V_{CC} between 1.5V and 4V. OUT asserts low when V_{IN+} drops below V_{TH-} or when V_{IN-} exceeds V_{TH+} . OUT goes high after the timeout period (t_{TP}) when V_{IN+} exceeds V_{TH+} and V_{IN-} drops below V_{TH-} .
					MAX6460: Open-Drain Monitor Output. OUT requires an external pullup resistor. OUT asserts low for V_{CC} between 1.5V and 4V. OUT asserts low when V_{IN+} drops below V_{IN-} . OUT goes high when V_{IN+} is above V_{IN-} .
—	—	1	—	OUTA	Open-Drain Monitor A Undervoltage Output. OUTA requires an external pullup resistor. OUTA goes low when V_{IN+} drops below V_{TH-} and goes high when V_{IN+} exceeds V_{TH+} . OUTA also goes low for V_{CC} between 1.5V and 4V.
—	—	5	—	OUTB	Open-Drain Monitor B Overvoltage Output. OUTB requires an external pullup resistor. OUTB goes low when V_{IN-} exceeds V_{TH+} and goes high when V_{IN-} drops below V_{TH-} . OUTB also goes low when V_{CC} drops below 4V.
2	2	2	2	GND	Ground
3	3	3	3	IN+	Adjustable Undervoltage Monitor Threshold Input. Noninverting input for MAX6460.
—	4	4	4	IN-	Adjustable Overvoltage Monitor Threshold Input. Inverting input for MAX6460.
4	—	—	—	$\overline{\text{CLEAR}}$	Clear Input. For $V_{IN+} > V_{TH+}$, drive $\overline{\text{CLEAR}}$ high to latch OUT high. Connect $\overline{\text{CLEAR}}$ to GND to make the latch transparent. $\overline{\text{CLEAR}}$ must be low when powering up the device. Connect $\overline{\text{CLEAR}}$ to GND when not used.
—	—	—	5	REF	Reference. Internal 2.25V reference output. Connect REF to IN+ through a voltage divider for active-low output. Connect REF to IN- through a voltage divider for active-high output. REF can source up to 100 μ A and sink up to 300nA. Leave REF floating when not used. REF output is stable with capacitive loads from 0 to 50pF or greater than 1 μ F.
5	5	6	6	V_{CC}	Supply Voltage

High-Voltage, Low-Current Voltage Monitors in SOT Packages

Functional Diagrams

MAX6457-MAX6460

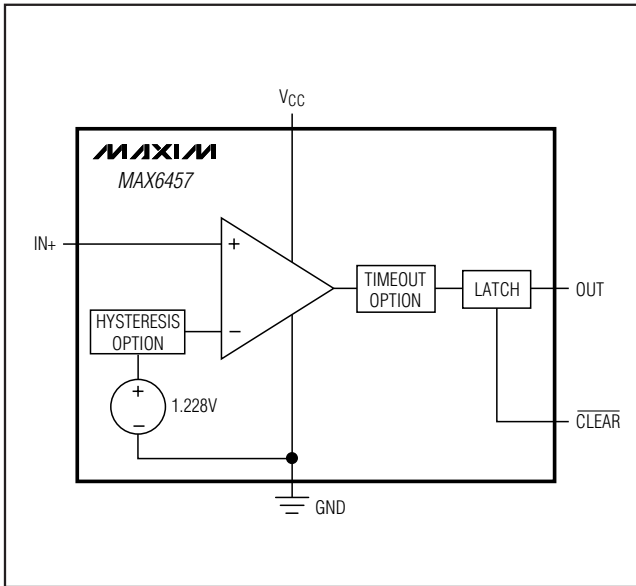

Figure 1. MAX6457 Functional Diagram

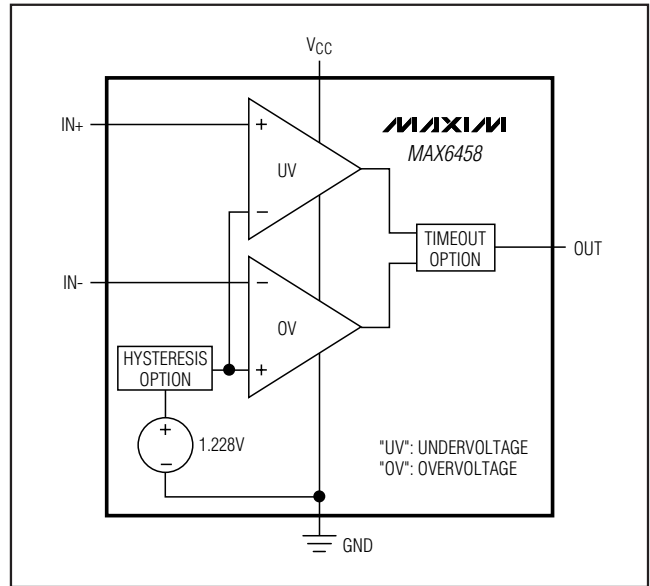

Figure 2. MAX6458 Functional Diagram

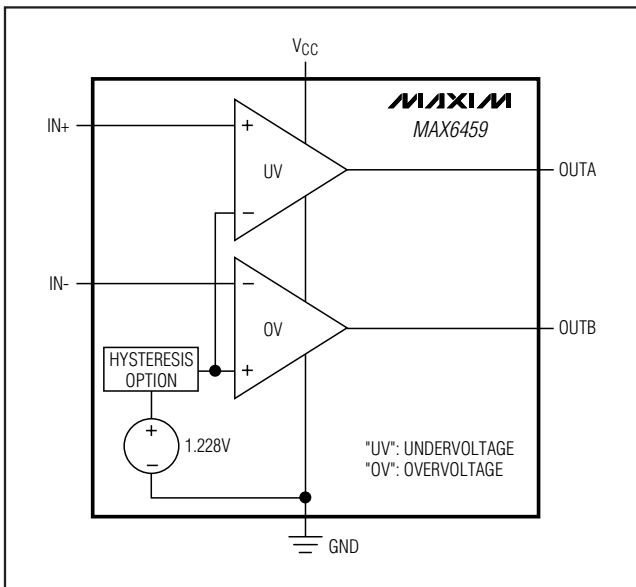

Figure 3. MAX6459 Functional Diagram

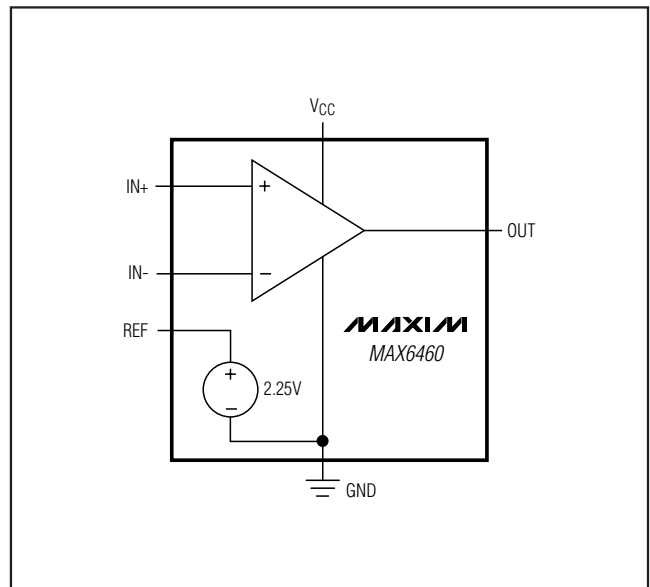

Figure 4. MAX6460 Functional Diagram

High-Voltage, Low-Current Voltage Monitors in SOT Packages

Detailed Description

Each of the MAX6457–MAX6460 high-voltage (4V to 28V), low-power voltage monitors include a precision bandgap reference, one or two low-offset-voltage comparators, internal threshold hysteresis, internal timeout period, and one or two high-voltage open-drain outputs.

Programming the Trip Voltage (VTRIP)

Two external resistors set the trip voltage, VTRIP (Figure 5). VTRIP is the point at which the applied voltage (typically VCC) toggles OUT. The MAX6457/MAX6458/MAX6459/ MAX6460's high input impedance allows large-value resistors without compromising trip-voltage accuracy. To minimize current consumption, select a value for R2 between 10kΩ and 1MΩ, then calculate R1 as follows:

$$R1 = R2 \left(\frac{V_{TRIP}}{V_{TH}} - 1 \right)$$

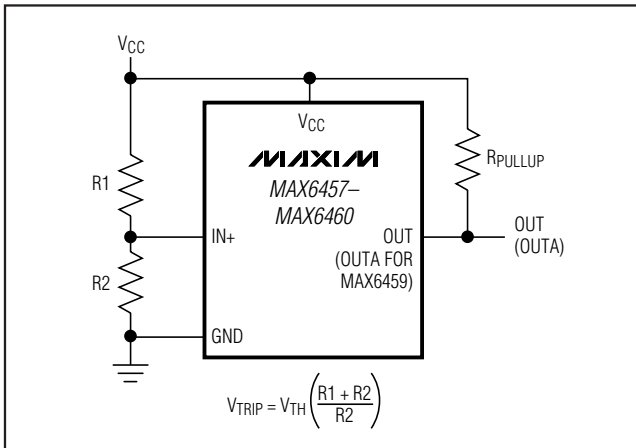

Figure 5a. Programming the Trip Voltage

where VTRIP = desired trip voltage (in volts), VTH = threshold trip voltage (VTH+ for overvoltage detection or VTH- for undervoltage detection).

Use the MAX6460 voltage reference (REF) to set the trip threshold by connecting IN+ or IN- through a voltage divider (within the inputs common-mode voltage range) to REF. Do not connect REF directly to IN+ or IN- since this violates the input common-mode voltage range. Small leakage currents into the comparators inputs allows use of large value resistors to prevent loading the reference and affecting its accuracy. Figure 5b shows an active-high power-good output. Use the following equation to determine the resistor values when connecting REF to IN-:

$$V_{REFD} = V_{REF} \left(\frac{R4}{R3 + R4} \right)$$

$$R1 = R2 \left(\frac{V_{TRIP}}{V_{REFD}} - 1 \right)$$

where VREF = reference output voltage (2.25V, typ), VREFD = divided reference, VTRIP = desired trip threshold in (in volts).

For an active-low power-good output, connect the resistor divider R1 and R2 to the inverting input and the reference-divider network to the noninverting input. Alternatively, connect an external reference less than 1.4V to either input.

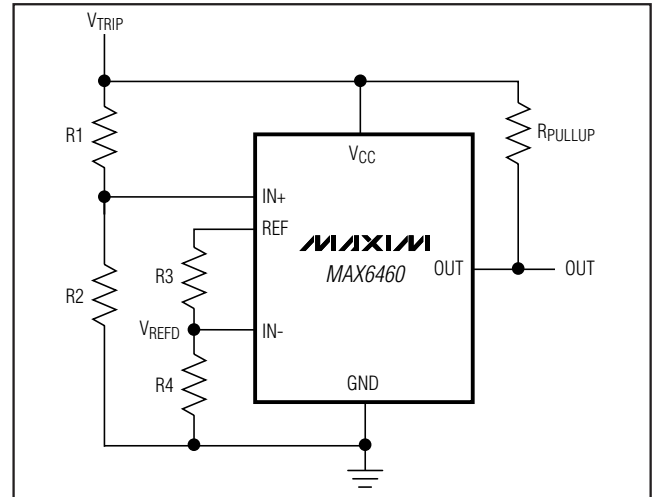

Figure 5b. Programming the MAX6460 Trip Voltage

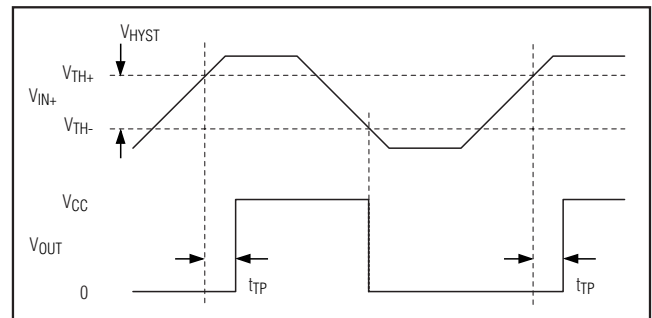

Figure 6. Input and Output Waveforms (Noninverting Input Varied)

High-Voltage, Low-Current Voltage Monitors in SOT Packages

MAX6457-MAX6460

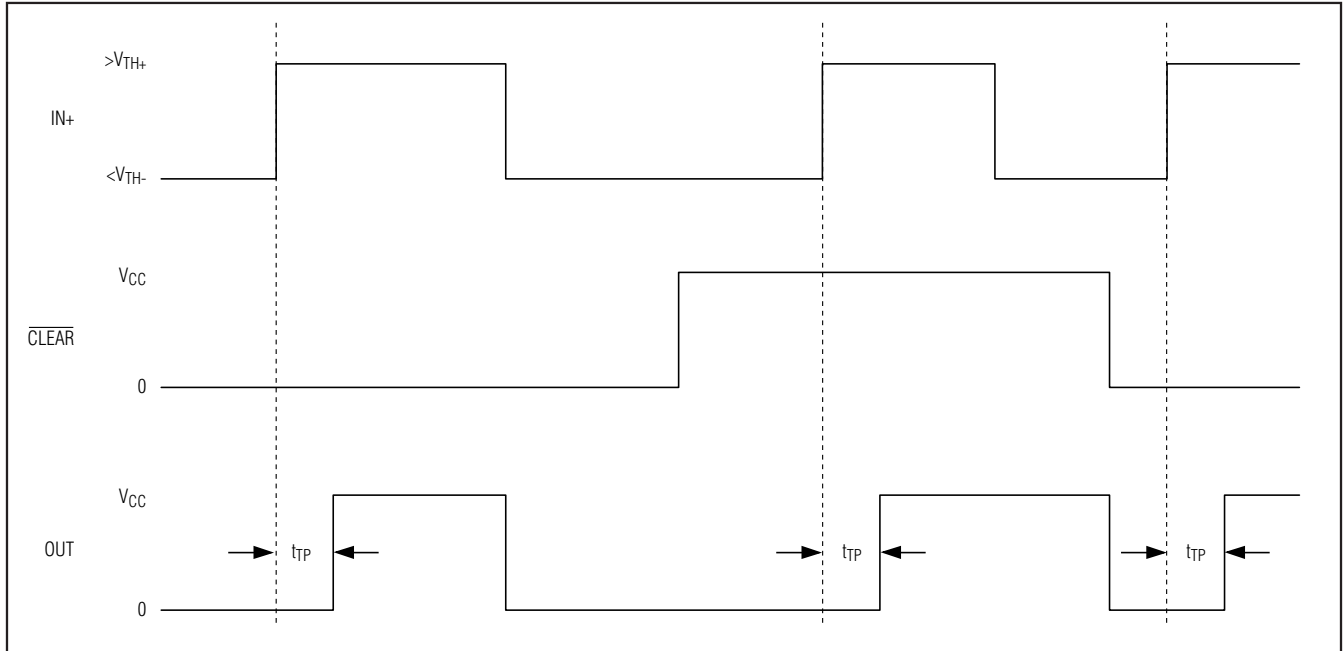

Figure 7. Timing Diagram (MAX6457)

Hysteresis

Hysteresis adds noise immunity to the voltage monitors and prevents oscillation due to repeated triggering when V_{IN} is near the threshold trip voltage. The hysteresis in a comparator creates two trip points: one for the rising input voltage (V_{TH+}) and one for the falling input voltage (V_{TH-}). These thresholds are shown in Figure 6.

The internal hysteresis options of the MAX6457/MAX6458/MAX6459 are designed to eliminate the need for adding an external hysteresis circuit.

Timeout Period

The timeout period (t_{TP}) for the MAX6457 is the time from when the input ($IN+$) crosses the rising input threshold (V_{TH+}) to when the output goes high (see Figures 6 and 7). For the MAX6458, the monitored voltage must be in the “window” before the timeout starts. The MAX6459 and MAX6460 do not offer the extended timeout option (150ms). The extended timeout period is suitable for overvoltage protection applications requiring transient immunity to avoid false output assertion due to noise spikes.

Latched-Output Operation

The MAX6457 features a digital latch input ($CLEAR$) to latch any overvoltage event. If the voltage on $IN+$ (V_{IN+}) is below the internal threshold (V_{TH-}), or if V_{CC} is below

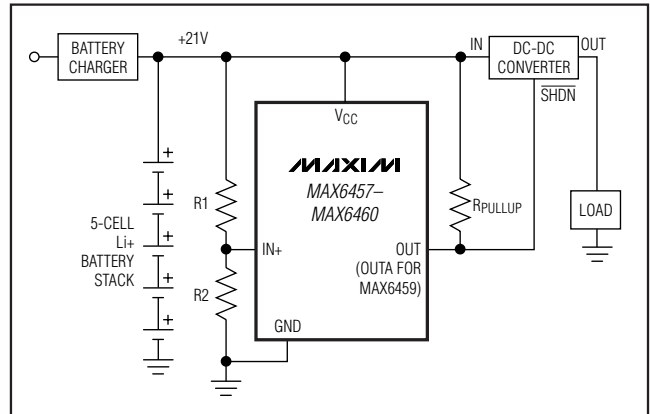

Figure 8. Undervoltage Lockout Typical Application Circuit

4V, OUT remains low regardless of the state of $CLEAR$. Drive $CLEAR$ high to latch OUT high when V_{IN+} exceeds V_{TH+} . When $CLEAR$ is high, OUT does not deassert if V_{IN+} drops back below V_{IN-} . Toggle $CLEAR$ to deassert OUT . Drive $CLEAR$ low to make the latch transparent (Figure 7). $CLEAR$ must be low when powering up the MAX6457. To initiate self-clear at power-up, add a $100k\Omega$ pullup resistor from $CLEAR$ to V_{CC} and a $1\mu F$ capacitor from $CLEAR$ to GND to hold $CLEAR$ low. Connect $CLEAR$ to GND when not used. See Figure 9.

High-Voltage, Low-Current Voltage Monitors in SOT Packages

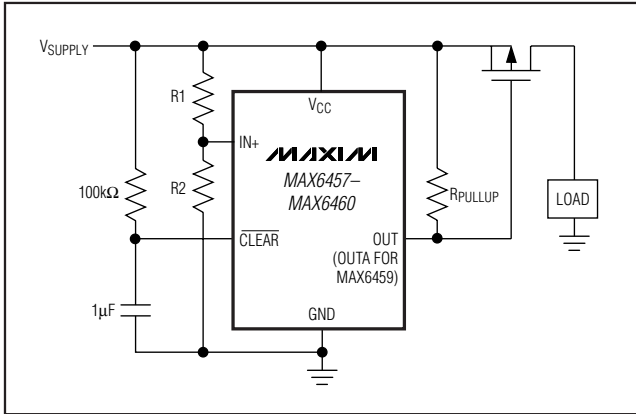

Figure 9. Overvoltage Shutdown Circuit (with External Pass MOSFET)

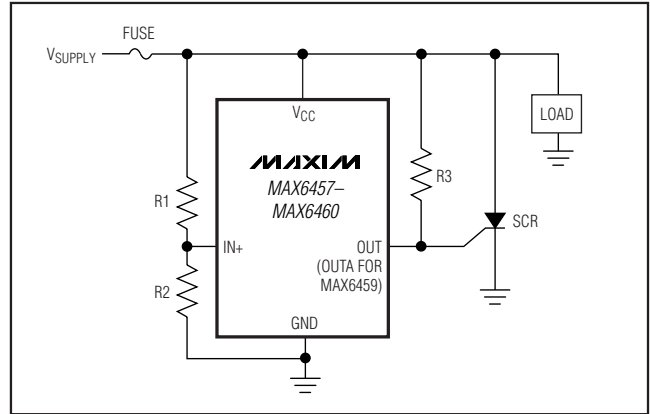

Figure 10. Overvoltage Shutdown Circuit (with SCR Fuse)

Applications Information

Undervoltage Lockout

Figure 8 shows the typical application circuit for detecting an undervoltage event of a 5-cell Li+ battery stack. Connect OUT of the MAX6457/MAX6458/MAX6460 (OUTA of the MAX6459) to the shutdown input of the DC-DC converter to cut off power to the load in case of an undervoltage event. Select R1 and R2 to set the trip voltage (see the *Programming the Trip Voltage (VTRIP)* section). When the voltage of the battery stack decreases so that V_{IN+} drops below V_{TH-} of the MAX6457-MAX6460, then OUT (OUTA) goes low and disables the power supply to the load. When the battery charger restores the voltage of the 5-cell stack so that $V_{IN+} > V_{TH+}$, OUT (OUTA) goes high and the power supply resumes driving the load.

Overvoltage Shutdown

The MAX6457-MAX6460 are ideal for overvoltage shutdown applications. Figure 9 shows a typical circuit for this application using a pass P-channel MOSFET. The MAX6457-MAX6460 are powered directly from the system voltage supply. Select R1 and R2 to set the trip voltage (see the *Programming the Trip Voltage (VTRIP)* section). When the supply voltage remains below the selected threshold, a low logic level on OUT (OUTB for MAX6459) turns on the p-channel MOSFET. In the case of an overvoltage event, OUT (OUTB) asserts high, turns off the MOSFET, and shuts down the power to the load.

Figure 10 shows a similar application using a fuse and a silicon-controlled rectifier (SCR). An overvoltage event turns on the SCR and shorts the supply to ground. The surge of current through the short circuit blows the fuse and terminates the current to the load. Select R3 so that the gate of the SCR is properly biased when OUT (OUTB) goes high impedance.

Window Detection

The MAX6458/MAX6459 include undervoltage and overvoltage comparators for window detection (Figures 2 and 3). The circuit in Figure 11 shows the typical configuration for this application. For the MAX6458, OUT asserts high when V_{CC} is within the selected "window." When V_{CC} falls below the lower limit of the window ($V_{TRIPLOW}$) or exceeds the upper limit ($V_{TRIPHIGH}$), OUT asserts low.

The MAX6459 features two independent open-drain outputs: OUTA (for undervoltage events) and OUTB (for overvoltage events). When V_{CC} is within the selected window, OUTA and OUTB assert high. When V_{CC} falls below $V_{TRIPLOW}$, OUTA asserts low while OUTB

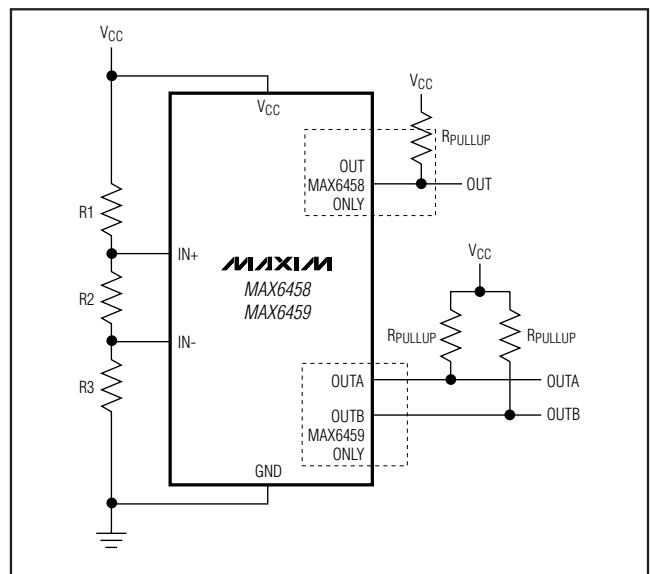

Figure 11. Window Detection

High-Voltage, Low-Current Voltage Monitors in SOT Packages

remains high. When V_{CC} exceeds $V_{TRIPHIGH}$, $OUTB$ asserts low while $OUTA$ remains high. $V_{TRIPLOW}$ and $V_{TRIPHIGH}$ are given by the following equations:

$$V_{TRIPLOW} = V_{TH-} \left(\frac{R_{TOTAL}}{R_2 + R_3} \right)$$

$$V_{TRIPHIGH} = V_{TH+} \left(\frac{R_{TOTAL}}{R_3} \right)$$

where $R_{TOTAL} = R_1 + R_2 + R_3$.

Use the following steps to determine the values for R_1 , R_2 , and R_3 .

- 1) Choose a value for R_{TOTAL} , the sum of R_1 , R_2 , and R_3 . Because the MAX6458/MAX6459 have very high input impedance, R_{TOTAL} can be up to $5M\Omega$.
- 2) Calculate R_3 based on R_{TOTAL} and the desired upper trip point:

$$R_3 = \frac{V_{TH+} \times R_{TOTAL}}{V_{TRIPHIGH}}$$

- 3) Calculate R_2 based on R_{TOTAL} , R_3 , and the desired lower trip point:

$$R_2 = \frac{V_{TH-} \times R_{TOTAL}}{V_{TRIPLOW}} - R_3$$

- 4) Calculate R_1 based on R_{TOTAL} , R_3 , and R_2 :

$$R_1 = R_{TOTAL} - R_2 - R_3$$

Example Calculations for Window Detection

The following is an example for calculating R_1 , R_2 , and R_3 of Figure 11 for window detection. Select the upper and lower trip points ($V_{TRIPHIGH}$ and $V_{TRIPLOW}$).

$V_{CC} = 21V$

$V_{TRIPHIGH} = 23.1V$

$V_{TRIPLOW} = 18.9V$

For 5% hysteresis, $V_{TH+} = 1.228$ and $V_{TH-} = 1.167$.

- 1) Choose $R_{TOTAL} = 4.2M\Omega = R_1 + R_2 + R_3$
- 2) Calculate R_3

$$R_3 = \frac{V_{TH+} \times R_{TOTAL}}{V_{TRIPHIGH}} = \frac{(1.228V)(4.2M\Omega)}{23.1V} = 223.273k\Omega$$

- 3) Calculate R_2

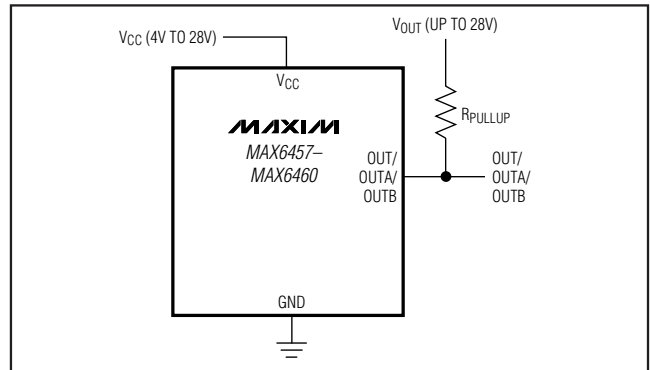

Figure 13. Interfacing to Voltages Other than V_{CC}

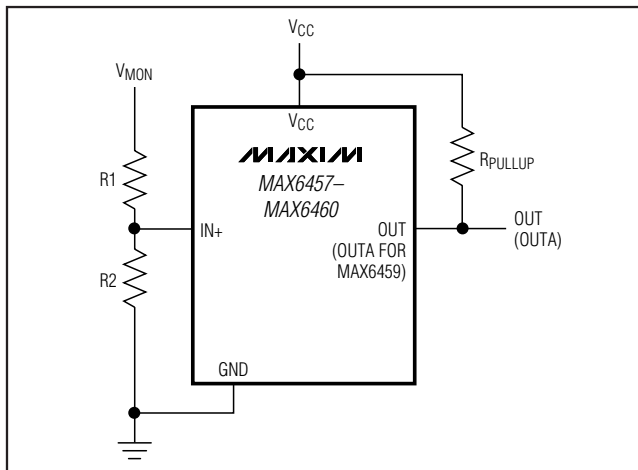

Figure 12. Monitoring Voltages Other than V_{CC}

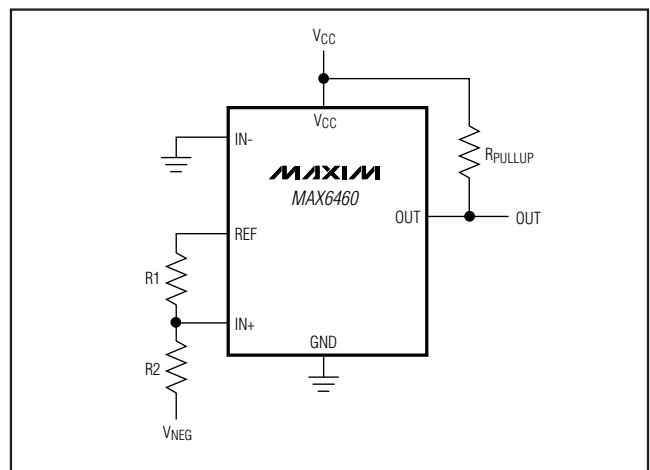

Figure 14. Monitoring Negative Voltages

High-Voltage, Low-Current Voltage Monitors in SOT Packages

Table 1. Factory-Trimmed Internal Hysteresis and Timeout Period Options

PART	SUFFIX	TIMEOUT OPTION	HYSTERESIS OPTION (%)
MAX6457UKD__-T MAX6458UKD__-T	0A	50µs	0.5
	0B	50µs	5
	0C	50µs	8.3
	3A	150ms	0.5
	3B	150ms	5
	3C	150ms	8.3
MAX6459UT_-T	A	50µs	0.5
	B	50µs	5
	C	50µs	8.3
MAX6460UT-T	N/A	50µs	0.5

Selector Guide

PART	PIN COUNT	LATCHED OUTPUT	NUMBER OF OUTPUTS	HYSTERESIS (%V _{TH+})	TIMEOUT PERIOD	TOP MARK	COMPARATORS
MAX6457UKD0A-T	5	✓	1	0.5	50µs	AEAA	1
MAX6457UKD3A-T	5	✓	1	0.5	150ms	AANN	1
MAX6457UKD0B-T	5	✓	1	5	50µs	AANL	1
MAX6457UKD3B-T	5	✓	1	5	150ms	AANO	1
MAX6457UKD0C-T	5	✓	1	8.3	50µs	AANM	1
MAX6457UKD3C-T	5	✓	1	8.3	150ms	ADZZ	1
MAX6458UKD0A-T	5	—	1	0.5	50µs	AANP	2
MAX6458UKD3A-T	5	—	1	0.5	150ms	AANS	2
MAX6458UKD0B-T	5	—	1	5	50µs	AANQ	2
MAX6458UKD3B-T	5	—	1	5	150ms	AEAB	2
MAX6458UKD0C-T	5	—	1	8.3	50µs	AANR	2
MAX6458UKD3C-T	5	—	1	8.3	150ms	AANT	2
MAX6459UTA-T	6	—	2	0.5	50µs	ABML	2
MAX6459UTB-T	6	—	2	5	50µs	ABEJ	2
MAX6459UTC-T	6	—	2	8.3	50µs	ABMM	2
MAX6460UT-T	6	—	1	0.5	50µs	ABEG	1

High-Voltage, Low-Current Voltage Monitors in SOT Packages

$$\begin{aligned}
 R2 &= \frac{V_{TH} \times R_{TOTAL}}{V_{TRIPLOW}} - R3 \\
 &= \frac{(1.167V)(4.2M\Omega)}{18.9V} - 223.273k\Omega \\
 &= 36.06k\Omega
 \end{aligned}$$

4) Calculate R1

$$\begin{aligned}
 R1 &= R_{TOTAL} - R2 - R3 \\
 &= 4.2M\Omega - 223.273k\Omega - 36.06k\Omega \\
 &= 3.94067M\Omega
 \end{aligned}$$

Monitoring Voltages Other than Vcc

The MAX6457-MAX6460 can monitor voltages other than VCC (Figure 12). Calculate VTRIP as shown in the *Programming the Trip Voltage (VTRIP)* section. The monitored voltage (VMON) is independent of VCC. VIN+ must be within the specified operating range: 0 to VCC.

Interfacing to Voltages Other than Vcc

The open-drain outputs of the MAX6457-MAX6460 allow the output voltage to be selected independent of VCC. For systems requiring an output voltage other than VCC, connect the pullup resistor between OUT, OUTA, or OUTB and any desired voltage up to 28V (see Figure 13).

Monitoring Negative Voltages

Figure 14 shows the typical application circuit for monitoring negative voltages (VNEG) using the MAX6460. Select a value for R1 between 25kΩ and 1MΩ. Use the following equation to select R2:

$$R2 = R1 \times \frac{-V_{NEG}}{V_{REF}}$$

where VREF = 2.25V and VNEG < 0. VIN+ must always be within the specified operating range: 0 to VCC.

Pin Configurations

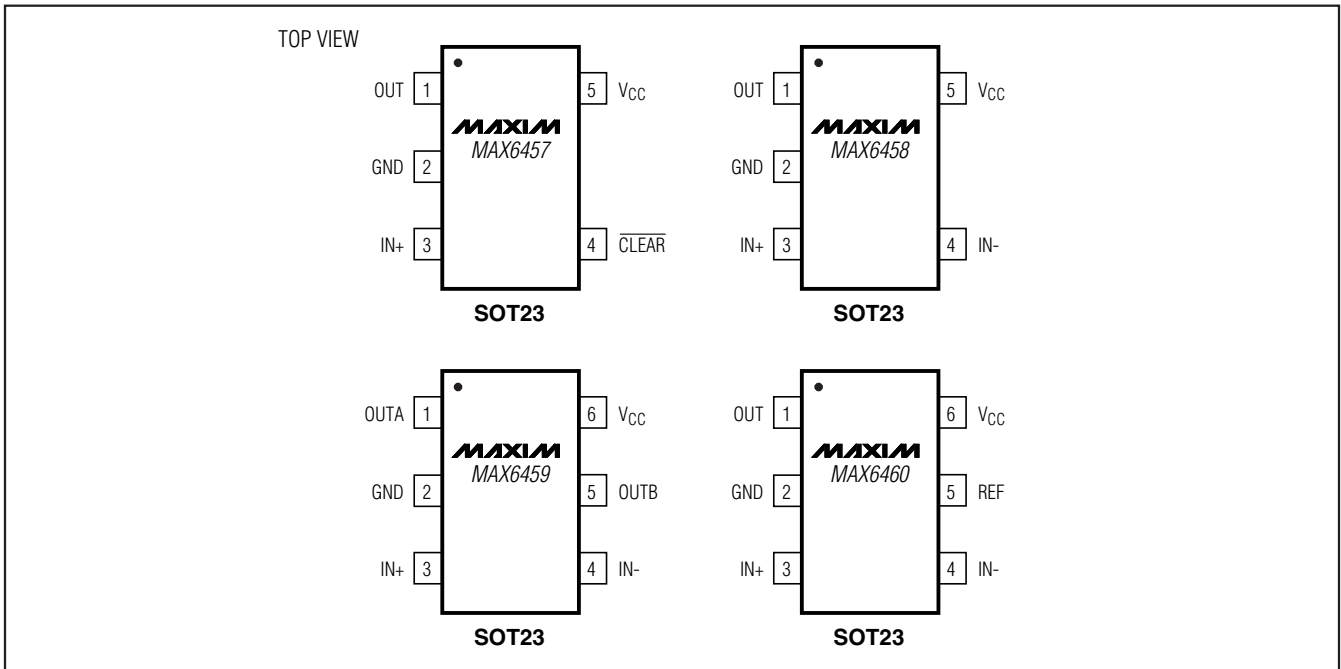

High-Voltage, Low-Current Voltage Monitors in SOT Packages

Chip Information

TRANSISTOR COUNT: 785
PROCESS: BiCMOS

Package Information

For the latest package outline information and land patterns, go to www.maxim-ic.com/packages.

PACKAGE TYPE	PACKAGE CODE	DOCUMENT NO.
5 SOT23	U5-1	21-0057
6 SOT23	U5-1	21-0058

High-Voltage, Low-Current Voltage Monitors in SOT Packages

Revision History

REVISION NUMBER	REVISION DATE	DESCRIPTION	PAGES CHANGED
0	7/02	Initial release	—
1	6/03	Updated the <i>Pin Description</i> and <i>Detailed Description</i> sections.	6, 8
2	12/05	Added lead-free notation to <i>Ordering Information</i> .	1
3	1/07	Updated the <i>Pin Description</i> and Figures 5a, 9, 12.	6, 8, 10, 11, 13-16
4	3/09	Updated the <i>Programming the Trip Voltage (V_{TRIP})</i> section.	8

MAX6457-MAX6460

Maxim cannot assume responsibility for use of any circuitry other than circuitry entirely embodied in a Maxim product. No circuit patent licenses are implied. Maxim reserves the right to change the circuitry and specifications without notice at any time.

Maxim Integrated Products, 120 San Gabriel Drive, Sunnyvale, CA 94086 408-737-7600 _____ 15

© 2009 Maxim Integrated Products

Maxim is a registered trademark of Maxim Integrated Products, Inc.